

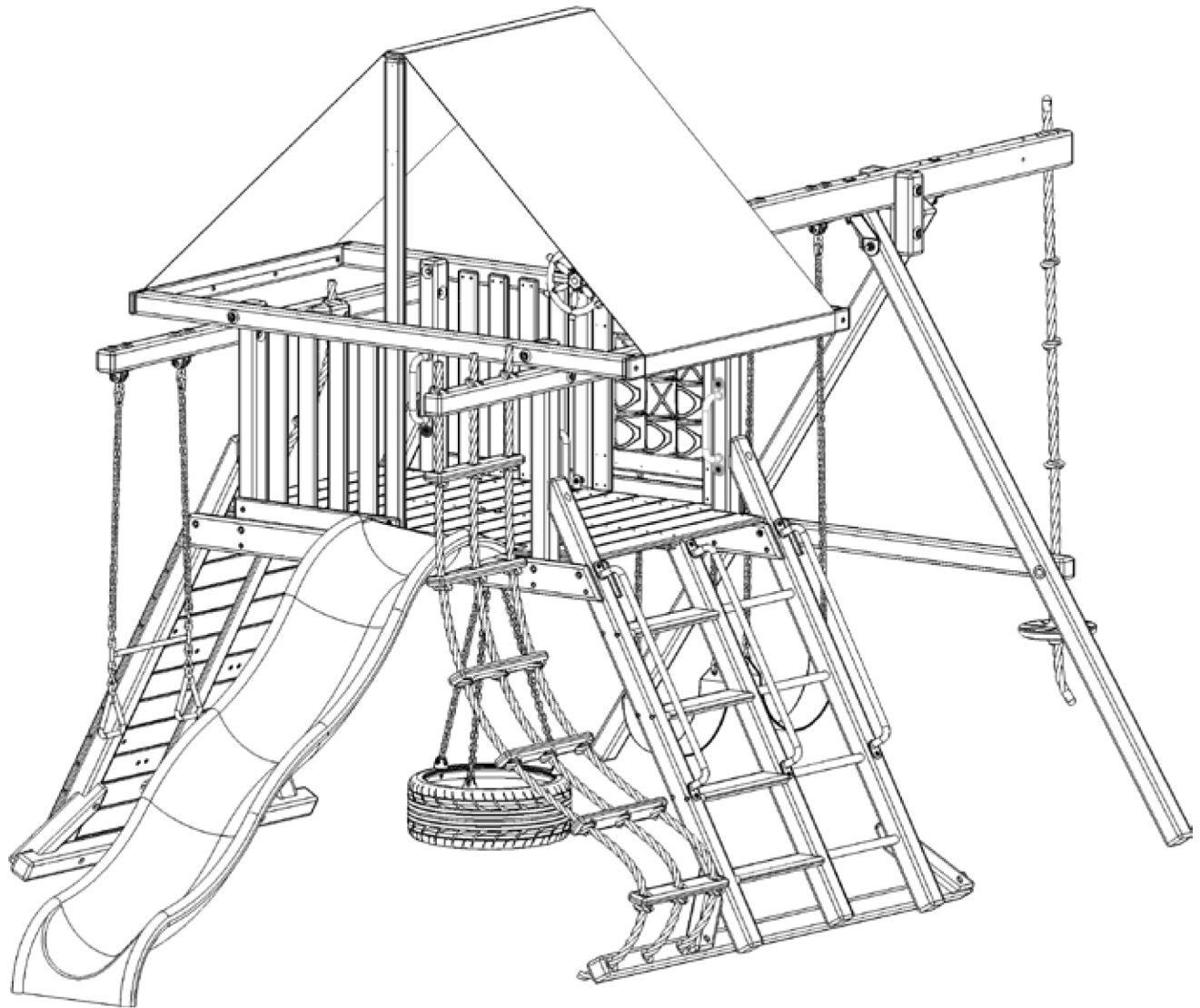

# PARROT ISLAND PLAYCENTER



Version 1:20



4465 West Sam Houston Parkway N.  
Houston, Texas 77041  
[WWW.TREEFROGSSHOWROOMS.com](http://WWW.TREEFROGSSHOWROOMS.com)  
© 2018 KID STRUCTURES INC.

**Parrot Island Playcenter Sections**  
Section 1: Cover & Liability Info  
Section 2: Product Parts  
Section 3: Sub Assemblies  
Section 4: Base Assembly  
Section 5: Roof Options  
Section 6: Rail Options  
Section 7: Treehouse Option

## **IMPORTANT - PLEASE READ**

As fresh lumber acclimates to its new environment, the natural tendencies of the tree can show itself in the form of checks, or “cracks” in the lumber. In almost all cases this is normal and it will not affect the structural integrity of your play set.

Cosmetic defects that do not affect the structural integrity of the product, or natural defects of wood such as warping, checking or any other physical properties of wood that do not present a safety hazard, are not covered by this warranty.

Defects that develop because the product is exposed to extreme climate conditions are not covered by this warranty. Defects that develop as a result of faulty or improper installation of the product are also not covered by this warranty.

Most cracks are not warrantable, however if you believe that the integrity of your play set is compromised by this natural occurrence, please contact the Tree Frogs Swing Set Dealer that you purchased your swing set from.

We appreciate your purchase and know that you will enjoy your play system for many years to come.

### **Tools Needed for Assembly**

Tape Measure	24" Level	Angle Square
Phillips Screw Driver	3/8" Cordless Drill or Electric Drill	3/8" Drive Ratchet or Electric Impact Gun
Claw Hammer or Rubber Mallet	Pliers or Vise Grips	7/16" Deep Well Socket
9/16" Deep Well Socket	3/4" Deep Well Socket	1/8", 1/4", and 9/16" Drill Bits
Phillips Head Screw Bits	An Adult with two Adult Helpers	

Please familiarize yourself with the install manual, parts/components and general construction process of your new swing set before getting started. Approximate assembly time: 6 to 8 hours. 6 foot unobstructed safety perimeter around swingset recommended.

## **Pre-Assembly Hints**

- Depending on your experience, assembly of our play sets can take as little as 6 hours up to 24 hours, depending on size, after inventory of parts; therefore, we recommend you set aside a full two days for assembly.
  - Identify all of the parts for your play set. Empty each box and lay out boards so you can see each part. Your instruction book will have detailed drawings that will make it easy for you to recognize individual parts. Keep all hardware and metal parts separate from wooden pieces.
  - After everything is laid out, check carefully to ensure all parts are present. Make sure there are no broken boards.
  - Find an area to sort your hardware. It is best to open the hardware on a solid surface so that you do not lose any pieces in the grass.  
This will save time and familiarize you with all the different pieces in the hardware bag.
- \*\*Important note: Wood has some natural defects such as knots, surface cracks, etc... We reject parts that are structurally defective. We use a high quality lumber in our structures; however, you should inspect each part for splinters or rough spots and sand them smooth to prevent injury.\*\***
- After familiarizing yourself with all of the components, read all instructions thoroughly. Reading instructions after you have studied the parts will help you understand more clearly the installation process, and help to eliminate unnecessary mistakes.
  - Pay close attention to the diameter and length of each bolt and screw.
  - Never tighten hardware completely at first. It helps to have some adjustment for bolt alignment while you are attaching parts together. After everything is square, tighten each joint.
  - After the main unit is assembled it is critical that the floor is level and square. If the main frame is not level, the walls and floor will be out of square.
  - After you complete installation, make sure every bolt, screw, and nut is tight, and every board is secure. Wood will expand and contract with the seasons.
  - Place the set on level ground, not less than 6ft from any structure or obstruction such as a fence, garage, house, overhanging branches, laundry lines, or electrical wires.
  - All 1/4" and 3/8" lag bolts must have pre-drilled holes 1-1/2" to 2" deep. Use a 1/8" drill bit for the 1/4" lag bolts and 1/4" drill bit for 3/8" lag bolts. Use pre-drilled holes in facias as a reference for placing lag bolt pilot holes.
  - If a board lifts or rises causing a gap between boards when running in lag bolts or screws, back out the screw or lag bolt and press or apply pressure (but not enough to crack or break board) while re-running in the lag bolt or screw in the same hole.
  - Do not over tighten bolts, lag bolts or screws. You can damage boards, break hardware, and/or strip out the hardware.
  - When using hammer do not beat on the hardware, but gently tap it in. Never beat on the wood as it will leave marks.

## **Leveling Your Swing Set During Assembly**

- Complete the steps which will be the basic frame of the fort {i.e. four corner posts with base (sand box boards) and deck supports}
- Position in the most level area chosen for the play set, keeping in mind the location and size of the swing beam, ladder, slides, etc. that extend off the fort.
- Once the frame is in the final position, check for vertical and horizontal levelness to determine which side(s) will need to be dug into the ground to level the play set.
- With a shovel, score the ground around the outside edges of the sandbox boards on the 'high' side of the fort. This is the area that will be dug in. Make sure to score deep enough; the scored lines will be your digging template.
- Push the frame off and away from the scored area, far enough to dig and remove dirt to reach the appropriate depth.
- Dig a channel along the scored line(s) for the base of the fort (corner post and sandbox boards) to rest into. Dig the channel(s) to the same level depth. The bottom of the channel(s) should be level to each other so your frame doesn't teeter or rock because the channel(s) are uneven.
- Once you have removed enough grass and dirt, slide/push the frame into the channel(s). Place a level on the vertical and horizontal boards of the frame to determine if enough soil, or too much, was removed.
- Repeat this process until the basic frame is plumb and level and in its final position before completing the rest of the assembly.
- Measure to make sure fort is square.

**\*\* Important: if you require a channel depth of more than 6", then we recommend you have your play set area professionally graded before completing assembly. \*\***

## **Choosing A Location For Your Playset**

When choosing a location for your swing set, always keep your child or children's safety in mind. Here are some recommendations to help you locate and install a safe play area.

- This play set is designed for the use of 4 occupants who have a combined weight not exceeding 800 pounds on the elevated floor; 3 occupants who have a combined weight of 525 pounds on the swing area; for a total Unit capacity of 5 occupants who have a combined weight of 1325. (this weight is not including the picnic table area)
- On-site adult supervision is required.
- The swing set should be located on level ground. The stationary components such as ladders and slides are required to be a minimum of six feet from any structure or obstruction such as a fence, garage, house, tree, overhanging branches, electrical wires, clotheslines, etc. Any swinging equipment is also required to be a minimum distance twice the height of the swing beam away from these obstructions or structures as well. The swing set should be located a safe distance from any water hazards, such as a lake, river, bayou, swimming pool, etc.
- Do not install this residential swing set in a commercial setting. This swing set is not manufactured for commercial usage and will void all warranties. Tree Frogs Wooden Swing Set Factory is not responsible for any damages or injuries resulting from this swing set being used in a commercial setting.
- Never install this swing set indoors; or over concrete, asphalt, packed earth, grass, carpet or any other hard surface. A fall onto a hard surface can result in serious or fatal injury.
- The U.S. Consumer Product Safety Commission (CPSC) recommends that you install and maintain a resilient surface under your swing set. The CPSC's Consumer Information Sheet for Playground Surfacing Materials is on the next page. A resilient surface, should be installed after the swing set has been completely assembled according to these instructions. The swing set must rest on solid ground. Please note that this swing set has a maximum fall height of 7'.

## **Maintaining Your Swing Set**

**Here are some maintenance tips required to insure safe play on your swing set for years of fun.**

- At the beginning of each usage season and every two weeks during, check: nuts and bolts and tighten as needed, swing seats, chains, ladders, slides, rope and wood components for sign of deterioration and replace if necessary.
- On a yearly basis, we recommend that you coat your swing set with a sealant or preservative. You may also want to spot sand any areas prior to sealing.

**\*\* Special note: Although we recommend that you reseal your swing set annually, you may have to touch up the high traffic areas and/or areas that have a high exposure to direct sunlight. \*\***

- Be sure that the sealant you select is non-toxic and child safe. Your local Tree Frogs Wooden Swing Set Factory dealer may offer a complete power wash and reseal and maintenance program.
- Do not use line trimmers or "weed eaters" around your swing set. The line will remove both paint and wood from uprights and base pieces. Any damage resulting from this type of abuse is not covered under our limited warranty.
- Remove plastic swing seats and take in doors or do not use when temperature drops below 0°F.

**Please keep this install manual for future reference.**

## **To insure SAFE PLAY adults must teach children:**

- Not to walk close to, in front of, behind, or between moving items.
- Not to swing empty swing seats.
- Not to swing sideways into the path of adjacent swings.
- Not to use the swing set in a manner other than that for which it is intended.
- Not to get off the equipment while it is in motion.
- Not to jump off the tower.
- Not to stand in the swing seats.
- Not to swing so high that chains become slack, or above the height of the swing support.
- Not to jump on a slide.
- Not to climb on top of the swing support.
- Not to attach to the swing set any item that is not specifically designed for use with the equipment, such as (but not limited to) jump ropes, clotheslines, pet leashes, cables, and chains. These may become strangulation hazards.
- To hold on to swings and climbers with both hands.
- To slide feet first, never head first.
- To watch for other children while swinging or playing near the swing set.

## **To also insure SAFE PLAY adults must:**

- Limit climbing and swinging heights to each child's ability.
- Verify that suspended climbing ropes are secured at both ends.
- Verify that suspended climbing ropes cannot be looped back on themselves.
- Dress children appropriately for play. Use well-fitted shoes that do not have slippery soles.
- Avoid ponchos, scarves, hoods, loose fitting clothing, neckties, and any clothing with a drawstring. Serious injury could result should any part of the children's clothing become entangled in the swing set.
- Do not allow children to play wearing helmets.
- Remember that children are inventive. When they develop games that are unsafe, be alert and change the rules.

## **Weight limits for Treefrogs Swingsets**

Fort Platform: 800 Lbs.Total Weight.

Swing Belts: 175 Lbs.

Trapeze: 125 Lbs.

Full Bucket Swing: 50 Lbs.

Toddler Bucket Swing: 50 Lbs.

Tire Swing: 125 Lbs. Total Weight

Rope Ladder: 75 Lbs.

Rock Wall: 150 Lbs.

All Slides: 125 Lbs.

Tree Frogs recommends that the weight limits for all components must not be exceeded. Failure to adhere to these and other safety guidelines could result in damage to the swing set. and/or injury to the users.

## CONSUMER INFORMATION SHEET FOR PLAYGROUND SURFACING MATERIALS

The U.S. Consumer Product Safety Commission (CPSC) estimates that about 100,000 playground equipment related injuries resulting from falls to the ground surface are treated annually in U.S. hospital emergency rooms. Injuries involving this hazard pattern tend to be among the most serious of all playground injuries, and have the potential to be fatal, particularly when the injury is to the head. The surface under and around playground equipment can be a major factor in determining the injury-causing potential of a fall. It is self-evident that a fall onto a shock-absorbing surface is less likely to cause a serious injury than a fall onto a hard surface. However, it should be recognized that some injuries from falls will occur no matter what playground surfacing material is used.

Playground equipment should never be placed on hard surfaces such as concrete or asphalt. Grass may appear to be acceptable, but can turn to hard packed earth in areas of high traffic. Shredded bark mulch, wood chips, or fine gravel are considered to be acceptable shock absorbing surfaces when installed and maintained at a sufficient depth under and around play equipment.

TABLE 1 -CRITICAL HEIGHTS (in feet) OF TESTED MATERIAL

MATERIAL	UNCOMPRESSED DEPTH			COMPRESSED DEPTH
	6 Inch	9 Inch	12 Inch	9 inch
Wood Chips	7	10	11	10
Double Shredded Bark Mulch	6	10	11	7
Engineered Wood Fibers	6	7	>12	6
Fine Sand	5	5	9	5
Coarse Sand	5	5	6	4
Fine Gravel	6	7	10	6
Medium Gravel	5	5	6	5
Shredded Tires**	10-12	N/A	N/A	N/A

\*\* This is data from tests conducted by independent testing laboratories on a 6 inch depth of uncompressed shredded tire samples produced by four manufacturers. The test reported critical heights, which varied from 10 feet to greater than 12 feet. It is recommended that persons seeking to install shredded tires as a protective surface request test data from the supplier showing the critical height of the material when it was tested in accordance with ASTM F1292.

Table 1 should be read as follows: If, for example, uncompressed wood chips are used at a minimum of 6 inches, the Critical Height is 7 feet. If 9 inches of uncompressed wood chips are used, the Critical Height is 10 feet. It should be noted that, for some materials, the Critical Height decreases when the material is compressed. It is recommended that a shock absorbing material should extend a minimum of 6 feet in all directions from the perimeter of stationary equipment such as climbers and slides. However, because children may deliberately jump from a moving swing, the shock absorbing material should extend in the front and rear of a swing a minimum distance of 2 times the height of the pivot point measured from a point directly beneath the pivot on the supporting structure.

This information is intended to assist in comparing the relative shock-absorbing properties of various materials. No particular material is recommended over another. However, each material is only effective when properly maintained. Materials should be checked periodically and replenished to maintain correct depth as determined necessary for your equipment. The choice of a material depends on the type and height of the playground equipment, the availability in your area, and its cost.

This information has been extracted from the CPSC publications "Playground Surfacing-Technical Information Guide" and "Handbook for Public Playground Safety." Copies of these reports can be obtained by sending a postcard to:

Office of Public Affairs  
U.S. Consumer Product Safety Commission  
Washington, D.C. 20207

Toll-free Hotline: 1-800-638-2772 or at <http://www.cpsc.gov>

# 2018 TREE FROGS Limited Lifetime Warranty

## Limited 10-Year Warranty, Limited 5-Year Warranty

Tree Frogs Warranties all Jaguar Playcenter Series, Bengal Forts Series, MegaDeck Fort Series Redwood components and Cedar components against structural failure due to warping, wood rot, insect infestation (excluding Carpenter Bees) or decay for the period of 10 Years from the date of original purchase. This warranty does not cover cracks, fissions, checks, fading, knots and weathering that are normal natural characteristics of wood, that do not affect the structural integrity of the product. The Redwood and Cedar components warranty is extended to a Limited Lifetime Warranty to the original owner upon registering this warranty within 90 days of purchase at [www.treefrogsswingsets.com](http://www.treefrogsswingsets.com).

Tree Frogs Warranties all Parrot Island Fort Series, Parrot Island Playcenter Series, Rainforest Cottage Series Cedar components against structural failure due to warping, wood rot, insect infestation (excluding Carpenter Bees) or decay for a period of 10 Years from the date of original purchase. This warranty does not cover cracks, fissions, checks, fading, knots and weathering that are normal natural characteristics of wood, that do not affect the structural integrity of the product.

Tree Frogs Warranties all Toucan Fort Series, Toucan Playcenter Series, Orangutan Fort Series, Stand Alone Swings Cedar components against structural failure due to warping, wood rot, insect infestation (excluding Carpenter Bees) or decay for a period of 5 Years from the date of original purchase. This warranty does not cover cracks, fissions, checks, fading, knots and weathering that are normal natural characteristics of wood, that do not affect the structural integrity of the product.

In addition, a 10-Year Limited Warranty applies to all roto-molded slides, ductile iron swing hangers, tire swivels, metal climbing rungs and swing beam brackets against failure due to rust or failure in defect in material. Surface rust, fading, weathering, cracks/chips in coatings and corrosion that do not affect structural integrity are not covered by this warranty. Furthermore, a 5-Year Limited Warranty applies to all components & accessories including all swings, chain ladders, gliders, handles, brackets, bubble panels, tarps, steering/ships wheels, telescopes, binoculars, buoy ball, blow molded slides and disc seat that are not covered under the 10-Year Warranty to be free from defects in material and workmanship. Surface rust, fading, weathering, cracks/chips in coatings and corrosion that do not affect structural integrity are not covered by this warranty.

And for a period of 1-Year Tree Frogs warranties all ropes, structural foam molded slides to be free of defects in material and workmanship. Fading is not considered a defect and may occur with seasonal and geographical conditions.

**\*\*10-Year Warranty Exclusion: Toucan Fort Series, Toucan Playcenter Series, Orangutan Series, Stand Alone Swings (Limited 5Yr/5Yr/1Yr WARRANTY).**

This warranty is limited to a repair or replacement of the defective part. Product covered under this warranty will be shipped at the customer's expense. Tree Frogs is not responsible for any expense associated with freight, or delivery and installation of the warranted part(s). Tree Frogs reserves the right to inspect all warranty claim parts for which a claim has been made.

This limited warranty applies only to the original retail purchaser and for residential use only, non-residential use voids warranty. These warranties void when product is transferred or sold or no longer in possession by original owner. A copy of the original invoice must be presented to initiate warranty claim. This limited warranty does not cover damage from abuse, acts of God, vandalism, maintenance guideline neglect, alterations, normal wear & tear, use other than residential, unauthorized modification, damage due to moving of product or improper installation and or use. Any modification could damage the structural integrity of the play system and voids all warranties.

This warranty is exclusive and expressly in lieu of all other warranties, expressed or implied, including warranties of merchantability or fitness for use. Tree Frogs does not assume, or authorize any person to assume for us, any other liability in connection with the sale of our products.

This warranty gives you specific legal rights, and you also may have other rights that vary from state to state. Register your play system's warranty at [www.treefrogsswingsets.com](http://www.treefrogsswingsets.com).

Tree Frogs reserves the right at any time to change product specifications or substitute similar components.

See your instruction manual for guidelines on regular maintenance. <http://treefrogsshowrooms.com/installation-manuals/>. Your child's play system & perimeter play zone should be inspected regularly for any wear & safety hazards.

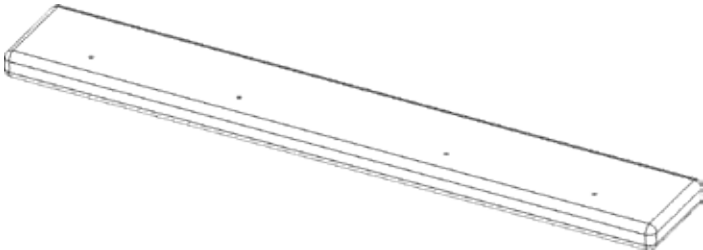
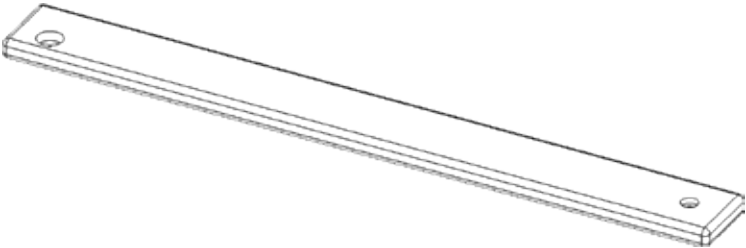
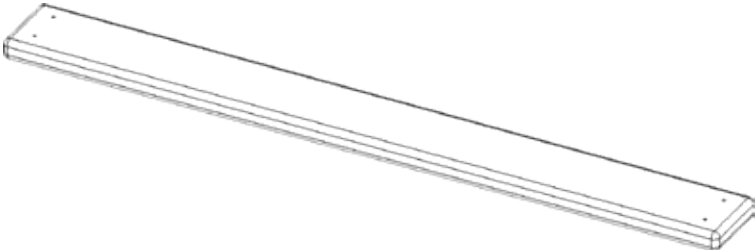
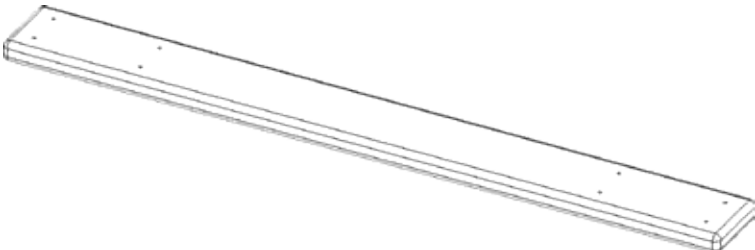
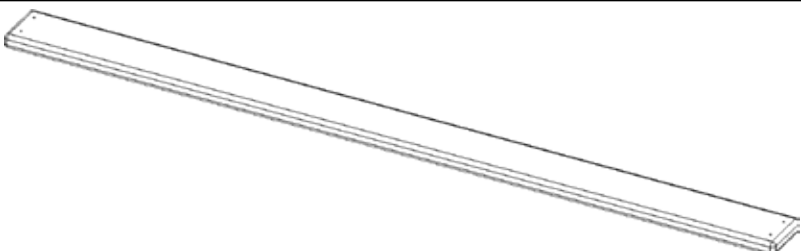
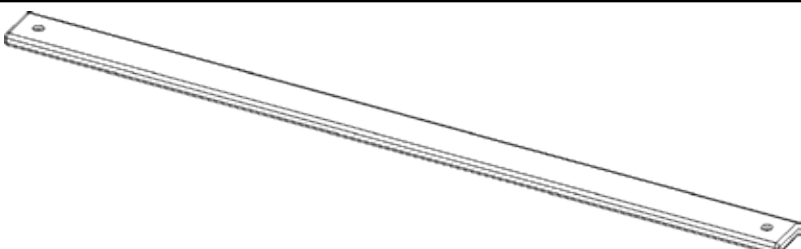
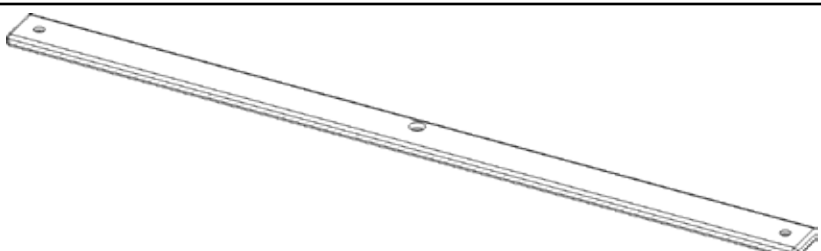
Picture	Description	QTY.
	<p>356-1 22" Tic Tac Toe Board</p>	<p>2</p>
	<p>356-2 31 15/16" Rail Facia</p>	<p>1</p>
	<p>356-3 32" Spindle</p>	<p>8</p>
	<p>356-4 32" Tic Tac Toe Spindle</p>	<p>2</p>
	<p>356-5 50" Center Tarp Board</p>	<p>1</p>
	<p>356-6 56 3/4" End Tarp Board</p>	<p>1</p>
	<p>356-7 60 1/2" Long Bottom Rail Facia</p>	<p>1</p>



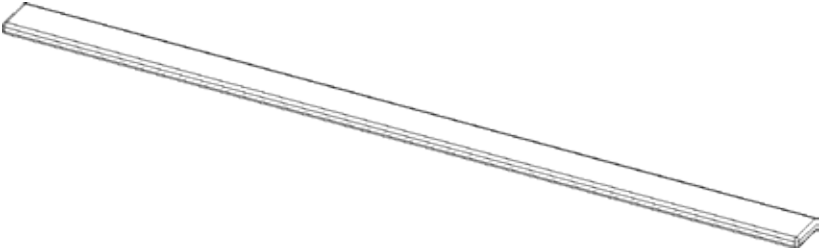
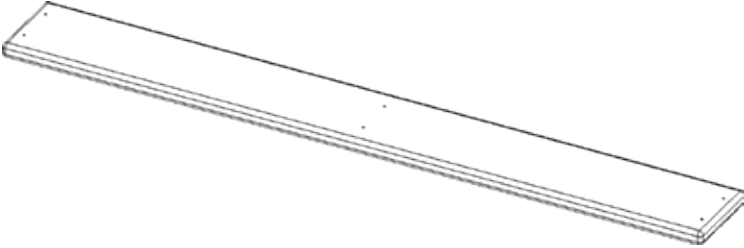
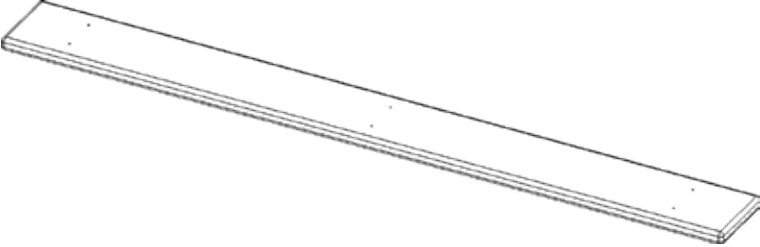
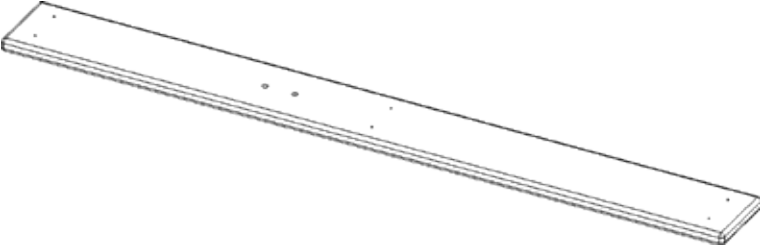
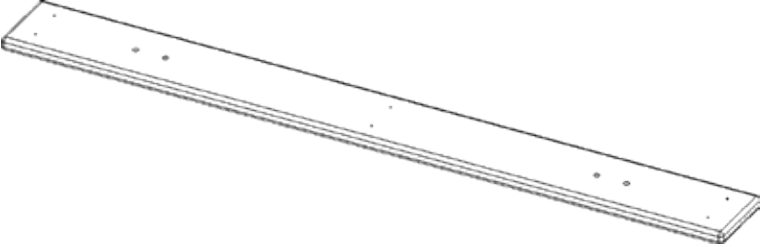
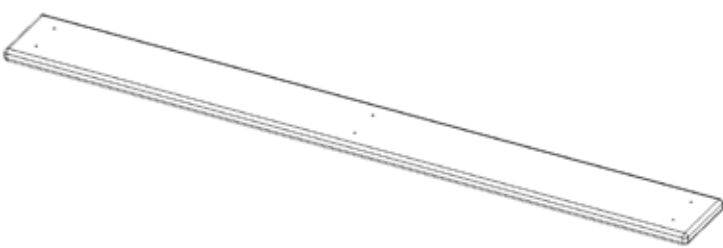
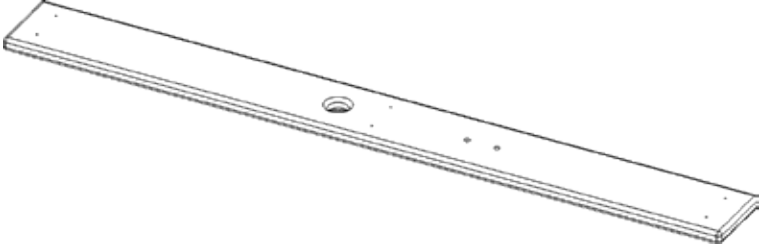

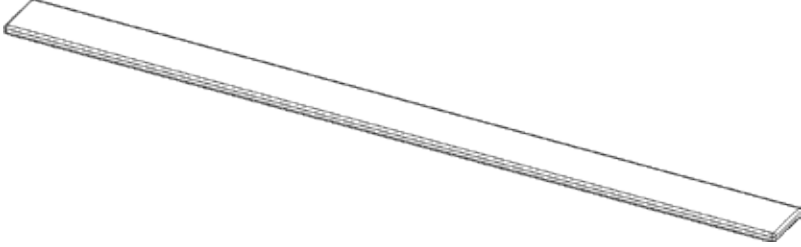
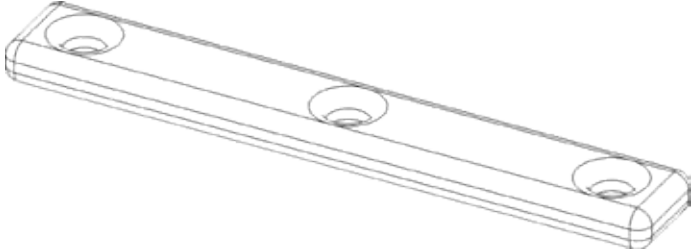
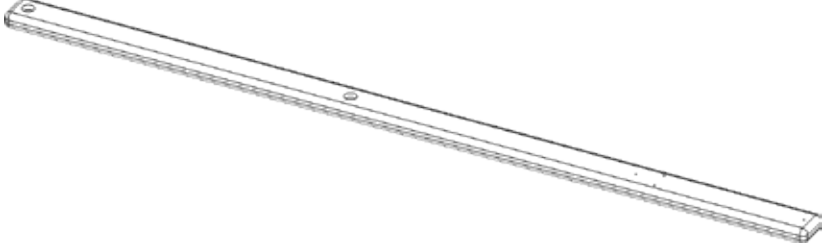
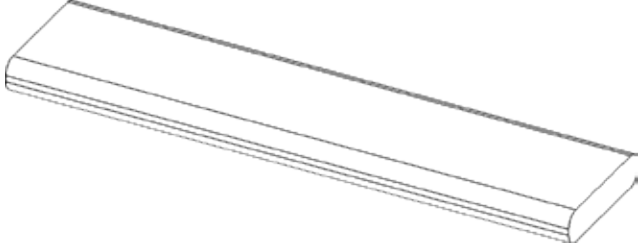
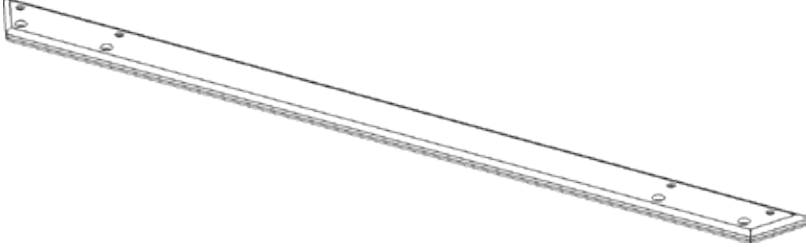
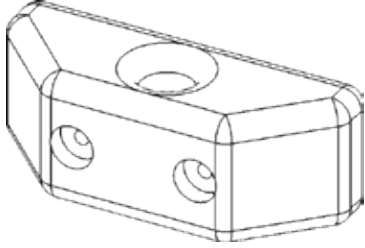
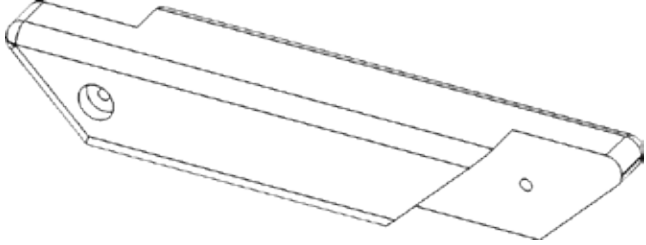

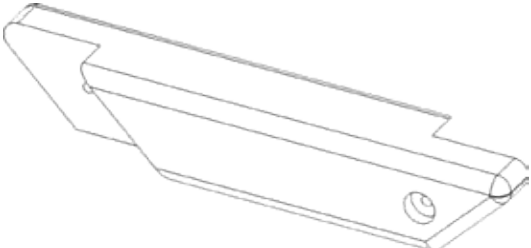
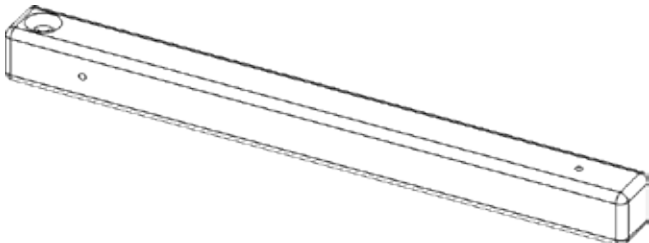
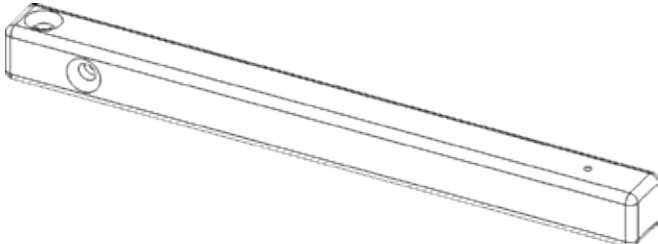
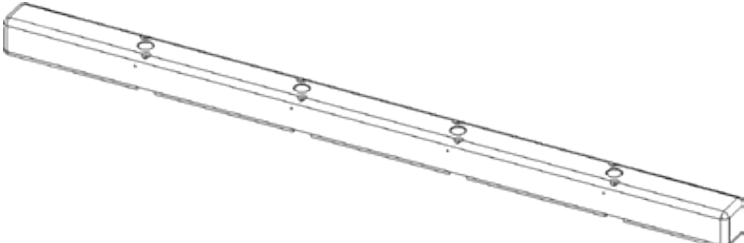
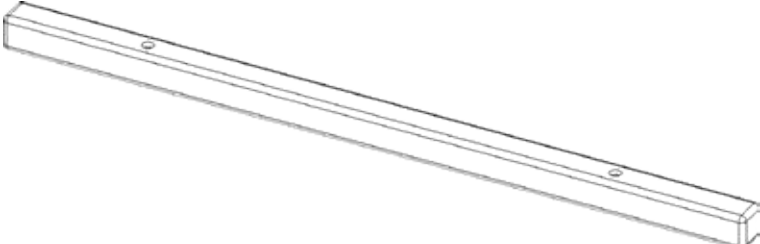
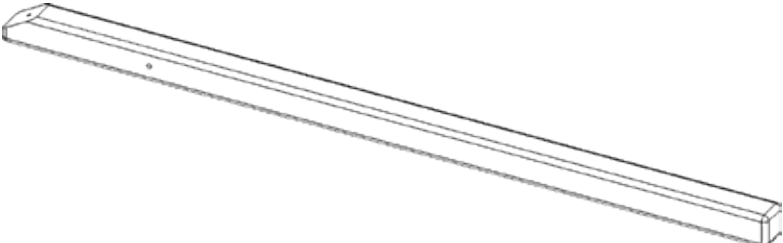
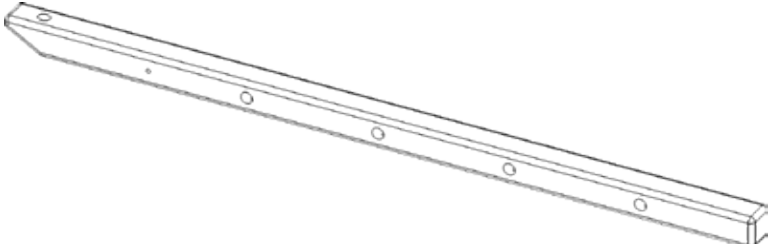
Picture	Description	QTY.
	<p>356-8 63" Rockwall Center Support</p>	<p>1</p>
	<p>356-9 43 1/4" Short Deck Board</p>	<p>4</p>
	<p>356-10 50" Deck Board</p>	<p>10</p>
	<p>356-11 50" 1- Rock Rockwall Board</p>	<p>5</p>
	<p>356-12 50" 2- Rock Rockwall Board</p>	<p>3</p>
	<p>356-13 50" Blank Rockwall Board</p>	<p>3</p>
	<p>356-14 50" Rockwall Board w/ Rope Hole</p>	<p>1</p>

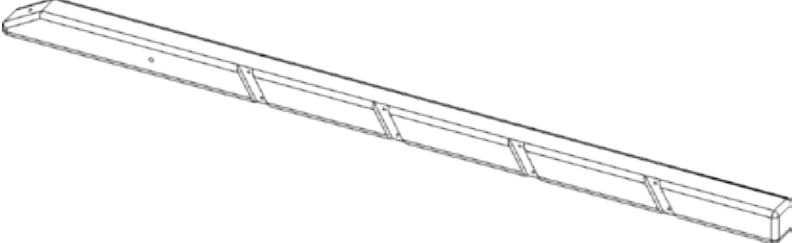
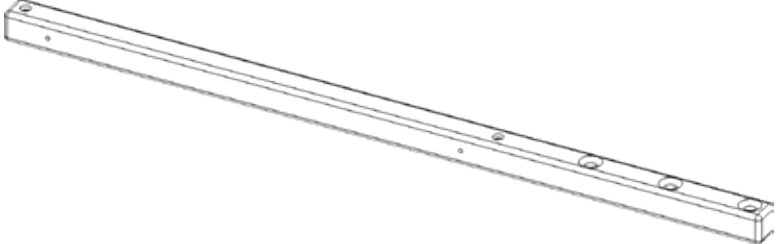
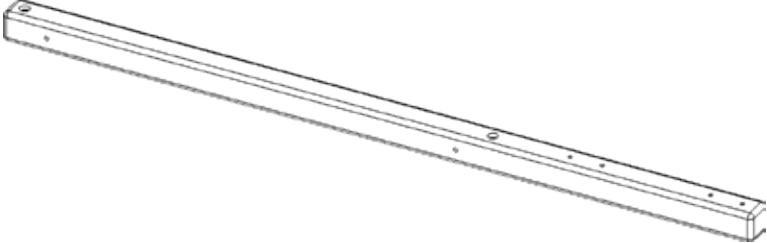
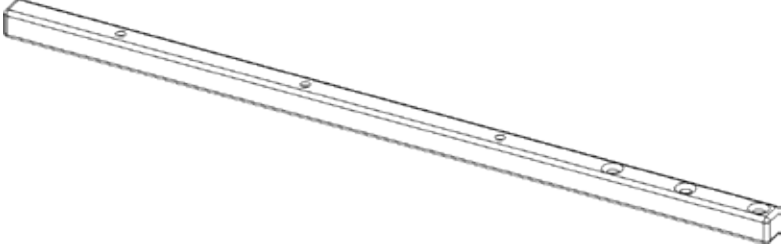
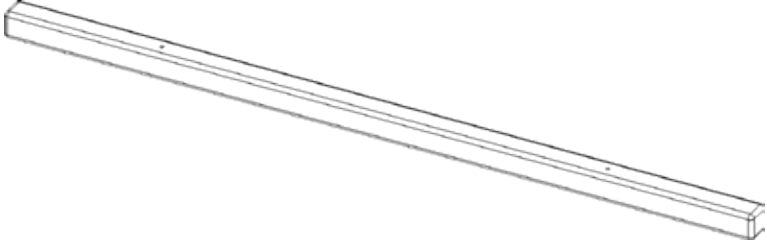
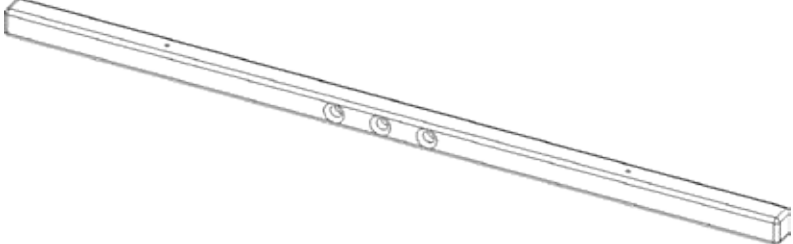
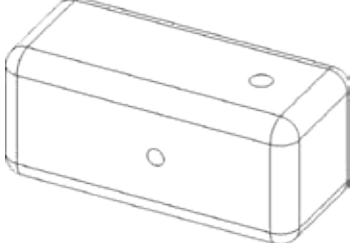
Picture	Description	QTY.
	<p>356-15 74 3/4" Deck Support</p>	<p>1</p>
	<p>356-16 22" Rope Ladder Rung</p>	<p>6</p>
	<p>356-17 75" Center Post</p>	<p>2</p>
	<p>356-18 21 9/16" Ladder Step</p>	<p>4</p>
	<p>356-19 83 1/8" Main Beam</p>	<p>4</p>
	<p>356-20 11" Rope Block</p>	<p>1</p>
	<p>356-21 19" (L) Gusset</p>	<p>3</p>

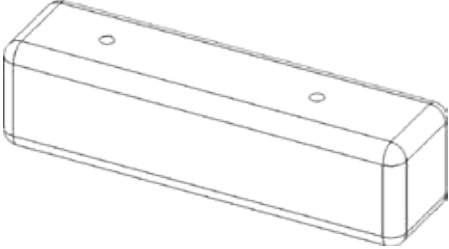
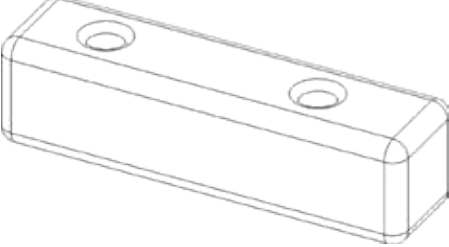
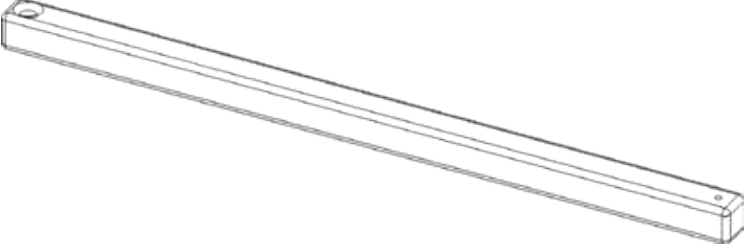
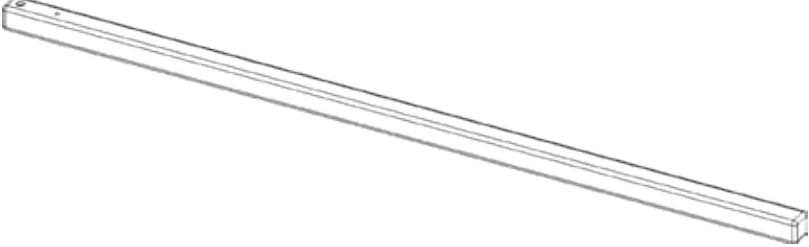
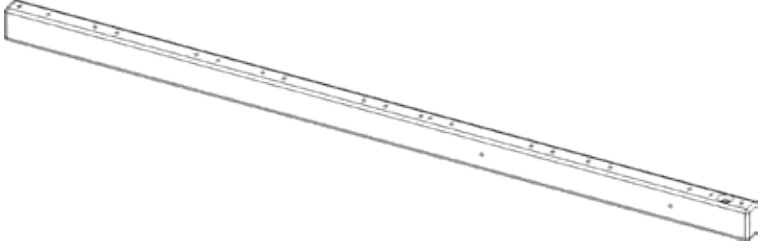

Picture	Description	QTY.
	<p>356-22 19" ( R ) Gusset</p>	<p>3</p>
	<p>356-23 39 7/16" ( R ) Corner Post</p>	<p>2</p>
	<p>356-24 39 7/16" ( L ) Corner Post</p>	<p>2</p>
	<p>356-25 65" Center Pipe &amp; Step Ladder Leg</p>	<p>1</p>
	<p>356-26 74" Ground Runner</p>	<p>1</p>
	<p>356-27 80" Rockwall Ladder Leg</p>	<p>2</p>
	<p>356-28 80" ( R ) Pipe Ladder Leg</p>	<p>1</p>

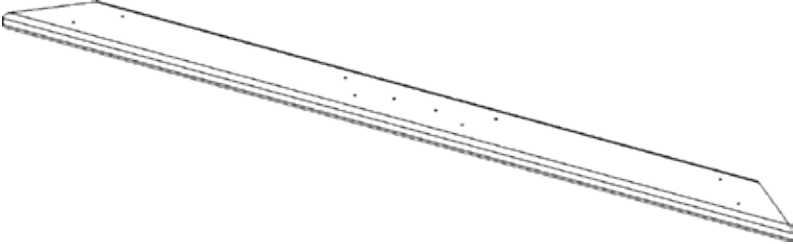
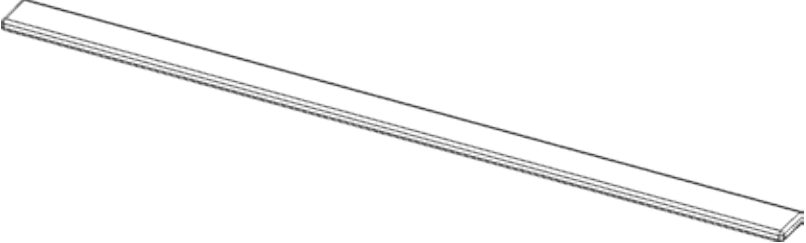
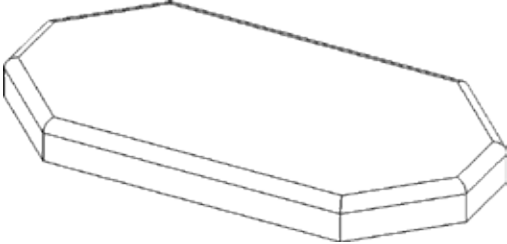
Picture	Description	QTY.
	<p>356-29 80" (L) Step Ladder Leg</p>	<p>1</p>
	<p>356-30 85 1/2" Rope Ladder Arm</p>	<p>1</p>
	<p>356-31 85 1/2" Trapeze Arm</p>	<p>1</p>
	<p>356-32 94 1/8" Rope Ladder Runner</p>	<p>1</p>
	<p>356-33 96" Top Joist</p>	<p>1</p>
	<p>356-34 96" SB Top Joist</p>	<p>1</p>
	<p>356-35 7 5/8" Center A-Frame Block</p>	<p>1</p>

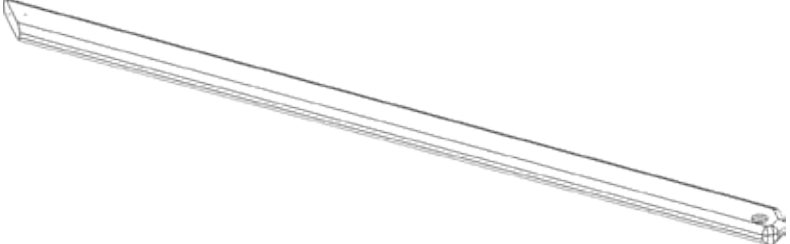
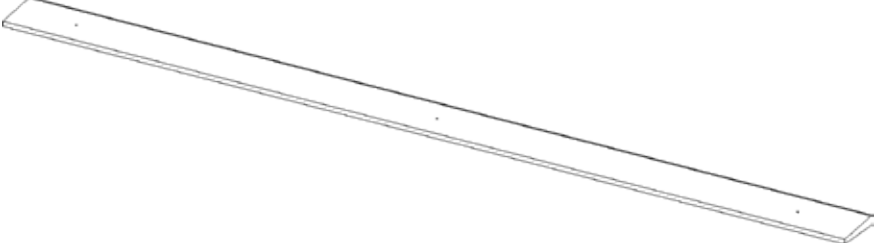
Picture	Description	QTY.
	<p>356-36 12 7/8" A-Frame Block</p>	<p>1</p>
	<p>356-37 12 7/8" A-Frame Block Sunked</p>	<p>1</p>
	<p>356-38 72" A-Frame Crossmember</p>	<p>1</p>
	<p>356-39 113" A-Frame Leg</p>	<p>2</p>
	<p>356-40 125" Universal Swingbeam</p>	<p>1</p>

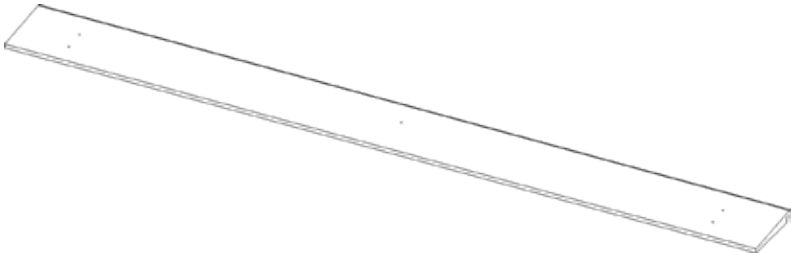
Picture	Description	QTY.
	<p>353-1 12 5/16" Short Fan Board</p>	<p>4</p>
	<p>353-2 43 11/26" Bottom Fan Board</p>	<p>2</p>
	<p>353-3 62" Center Wood Roof Support</p>	<p>2</p>
	<p>353-4 10" Center Fan Board</p>	<p>2</p>
	<p>353-5 11 5/8" Peak Facia</p>	<p>2</p>
	<p>353-6 63 3/4" Roof Supports</p>	<p>4</p>
	<p>353-7 56 3/4" Roof Board - Ripped</p>	<p>4</p>

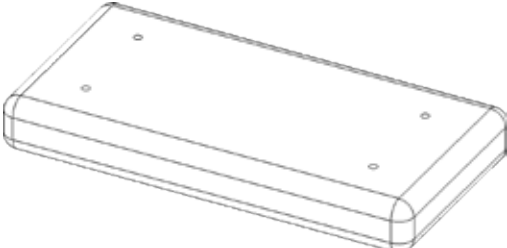
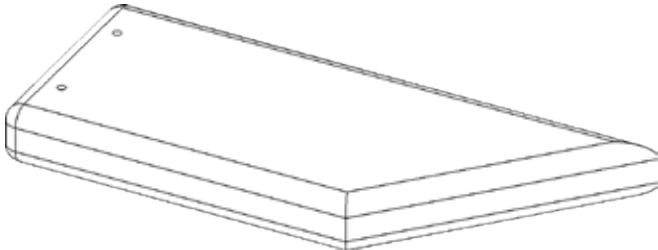
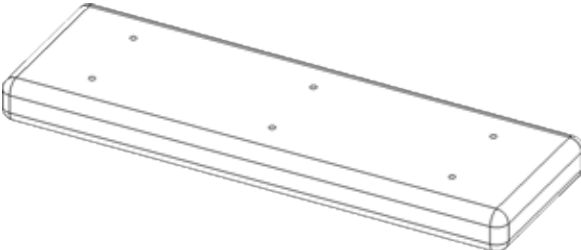
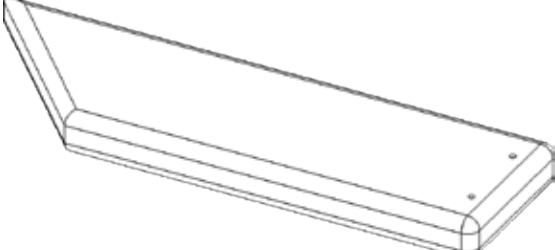
Picture	Description	QTY.
	353-7 56 3/4" Roof Board	28

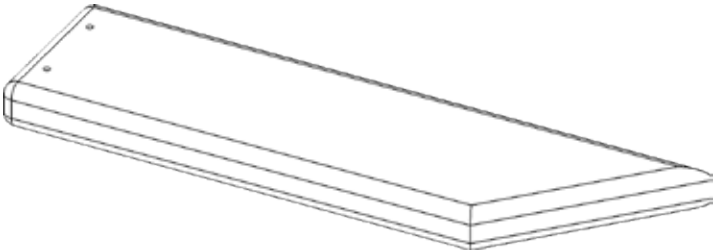
Picture	Description	QTY.
	<p>354-1 6 3/4" Short Picket - 17</p>	<p>8</p>
	<p>354-2 8 3/8" Panel Board - 2</p>	<p>4</p>
	<p>354-3 10 1/2" Panel Board - 12</p>	<p>4</p>
	<p>354-4 11 1/2" Panel Board - 3</p>	<p>4</p>
	<p>354-5 12" Right Window Shutter - 14</p>	<p>4</p>
	<p>354-16 12" Left Window Shutter - 13</p>	<p>4</p>
	<p>354-7 12 1/2" Panel Board - 8</p>	<p>4</p>

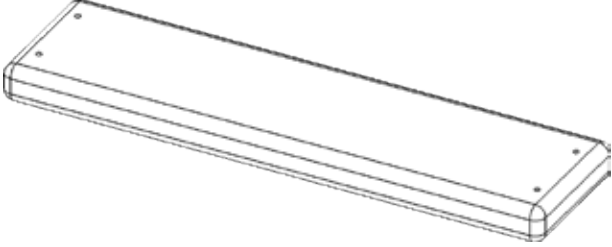
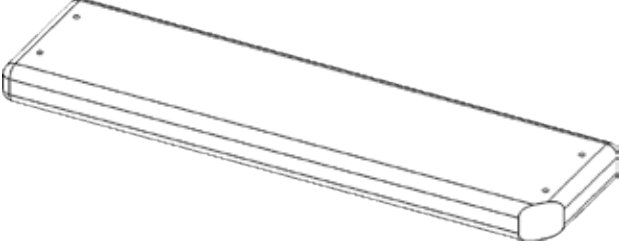
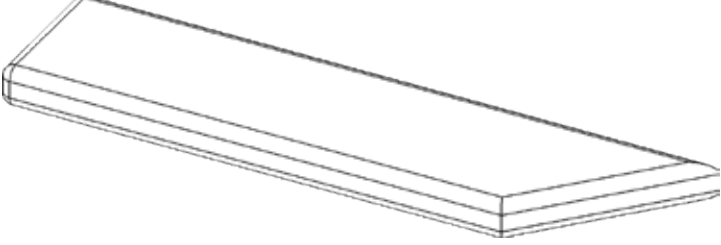
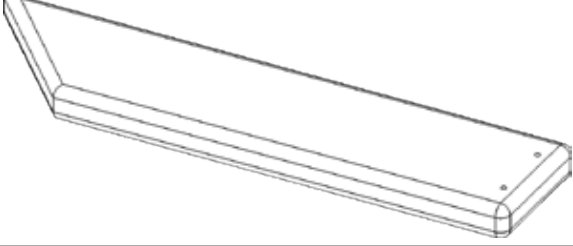
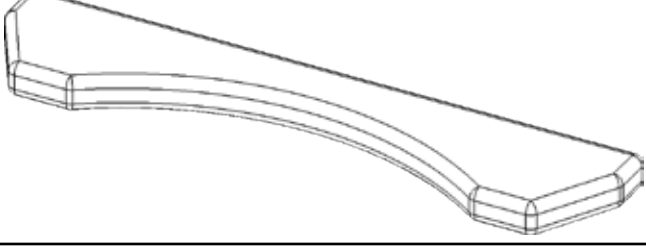
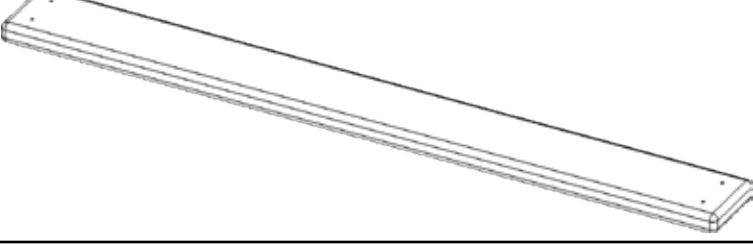
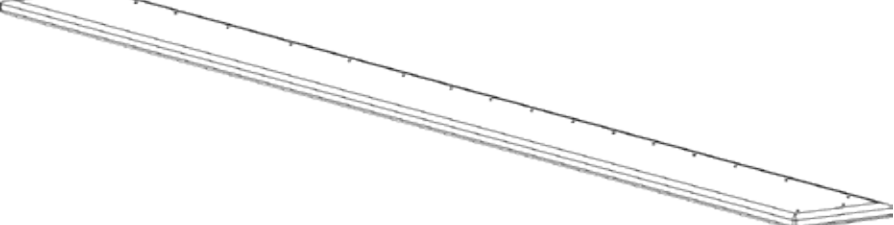

Picture	Description	QTY.
	<p>354-8 12 7/8" Panel Board - 10</p>	<p>4</p>
	<p>354-9 12 7/8" Panel Board - 9</p>	<p>4</p>
	<p>354-10 14 1/8" Panel Board - 5</p>	<p>4</p>
	<p>354-11 14 1/2" Panel Board - 4</p>	<p>4</p>
	<p>354-12 16" Window Top - 15</p>	<p>4</p>
	<p>354-13 32" Spindle</p>	<p>4</p>
	<p>354-14 48 5/8" Upper Support</p>	<p>4</p>

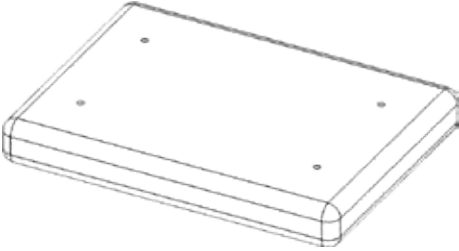
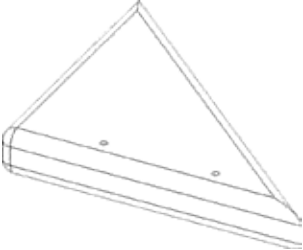
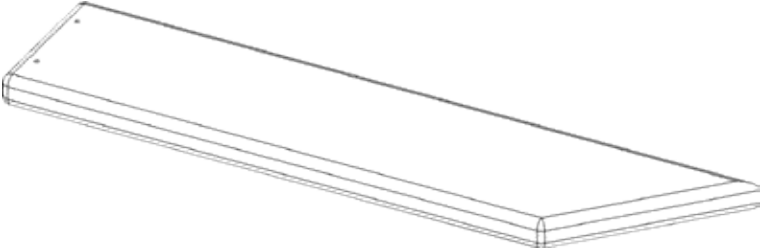
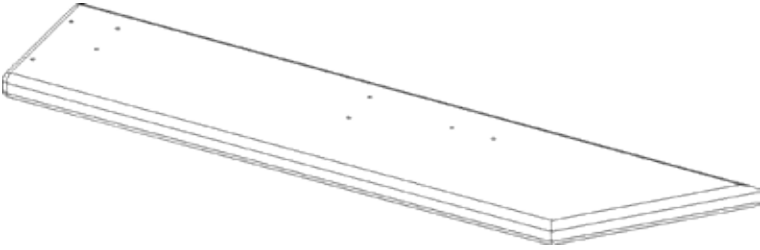
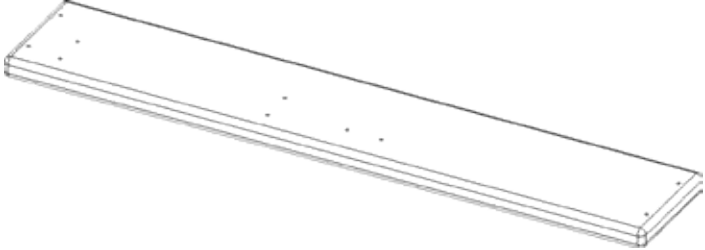
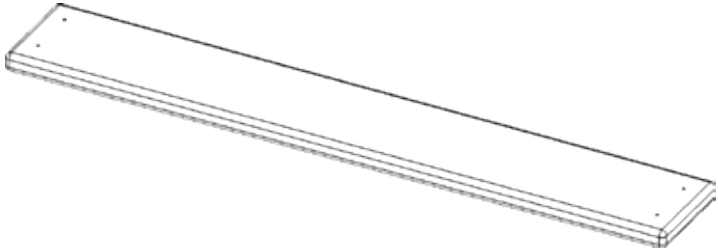
Picture	Description	QTY.
	<p>354-15 6 3/4" Short Wide Picket - 18</p>	<p>2</p>
	<p>354-16 5 15/16" Panel Board - 1</p>	<p>4</p>
	<p>354-17 19 7/8" Panel Board - 6</p>	<p>4</p>
	<p>354-18 24 9/16" Panel Board - 7</p>	<p>4</p>
	<p>354-19 28" Panel Board - 11</p>	<p>4</p>
	<p>354-20 32" Panel Spindle - 16</p>	<p>2</p>



# KSI-356-HWR BAG BASE HARDWARE

INSTALLER NOTE: (YOU MUST ASSEMBLE THIS PRODUCT IN ACCORDANCE WITH THESE ASSEMBLY INSTRUCTIONS. WHEN COMPLETE GIVE MANUAL TO OWNER.)

A-1  
3/8" Acorn Nut Plated  
QTY 22



A-2  
3/8" x 3" Carriage Bolt ZP  
QTY 2

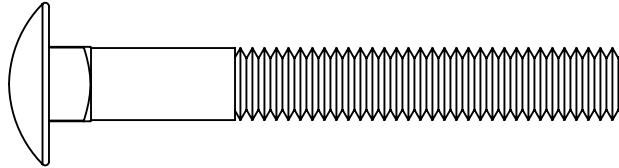

A-3  
3/8" x 1 1/2" Hex Bolt ZP  
QTY 2

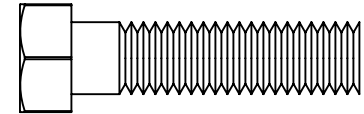

A-4  
3/8" x 5" Hex Bolt ZP  
QTY 4

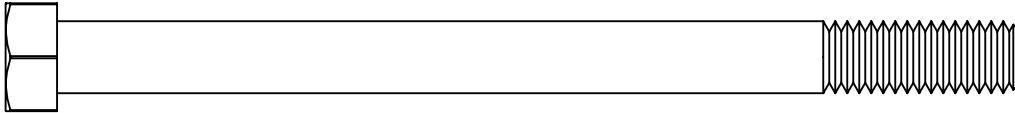

A-8  
1/2" USS Flatwasher ZP  
QTY 2

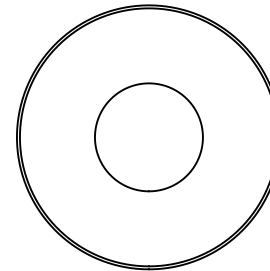

A-9  
3/8" Bolt Cup  
QTY 12

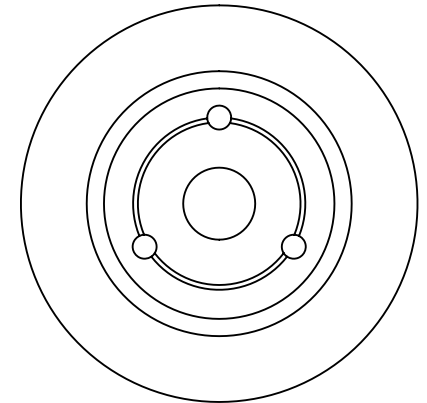

A-5  
3/8" x 6" Hex Bolt ZP  
QTY 8

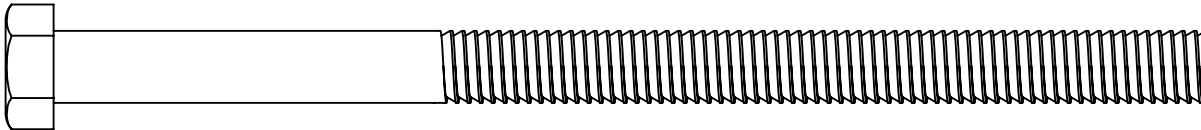

A-6  
3/8 x 6 1/2" Hex Bolt ZP  
QTY 8

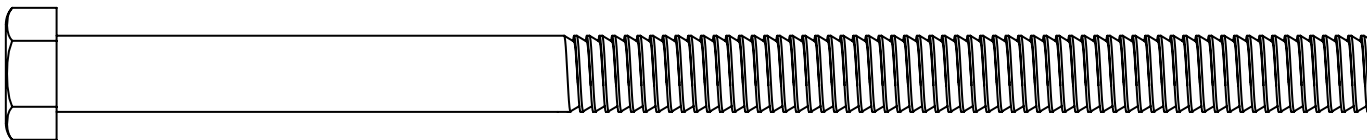

A-7  
3/8Nylon Insert Locknut NE ZP  
QTY 4

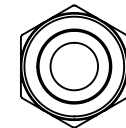

MEASUREMENT TAKEN FROM BOTTOM OF BOLT HEAD TO THE BOTTOM OF BOLT

USE A TAPE MEASURE OR RULER TO MEASURE YOUR BOLTS AND SCREWS. HARDWARE VIEWS SHOWN ABOVE ARE 1:1 SCALE AND CAN BE USED TO MATCH HARDWARE SIZES.

# KSI-356-HWR BAG BASE HARDWARE

INSTALLER NOTE: (YOU MUST ASSEMBLE THIS PRODUCT IN ACCORDANCE WITH THESE ASSEMBLY INSTRUCTIONS. WHEN COMPLETE GIVE MANUAL TO OWNER.)

A10  
M8x80  
QTY 5

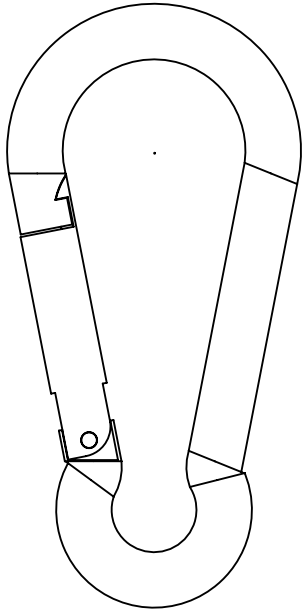

A11  
#2 & #3  
QTY 1



D  
#8 x 2" Coated Deck Screw  
QTY 62



E  
3/8" Hex Nut ZP  
QTY 12



B  
#8 x 1-1/2" Coated Deck Screw  
QTY 110

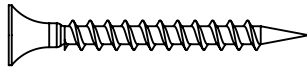

F  
1/4 x 3" Hex Lag Screw  
ZP QTY 20

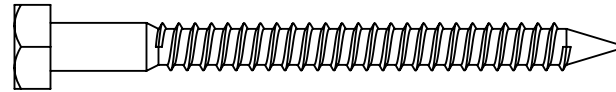

C  
#8 x 2" Coated Deck Screw  
QTY 62

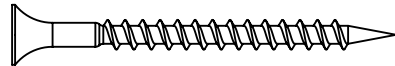

G  
1/4 x 4-1/2" Hex Lag Screw ZP  
QTY 20

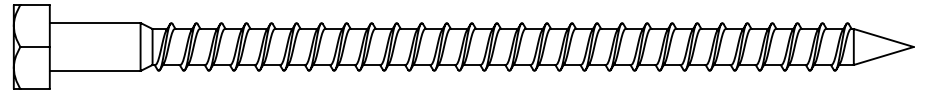

H  
3/8" x 3 1/2" Hex Lag Screw ZP  
QTY 18

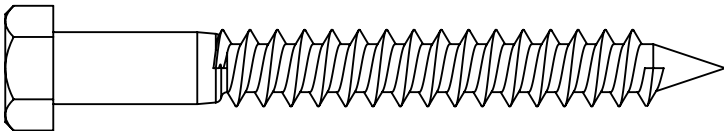

I  
3/8 x 5" Hex Lag Screw ZP  
QTY 15

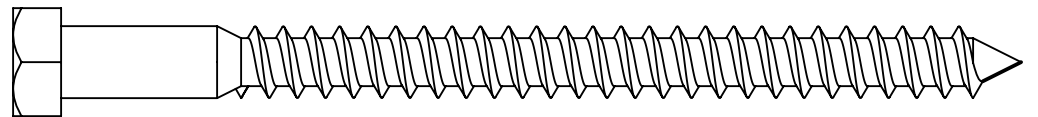

J  
#14 x 1" Pan Phillips T/S ZP  
QTY 12

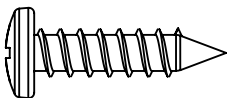

K  
#14 x 2" Pan Phillip T/S ZP  
QTY 14

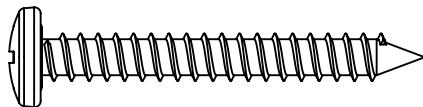

L  
1/4 x 1-1/4" Pan Phil M/S ZP QTY  
27

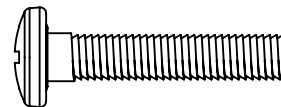

M  
2" Metal Tap Screw  
QTY 8

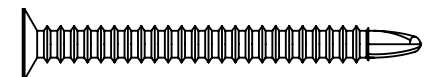

MEASUREMENT TAKEN FROM BOTTOM OF BOLT HEAD TO THE BOTTOM OF BOLT

USE A TAPE MEASURE OR RULER TO MEASURE YOUR BOLTS AND SCREWS. HARDWARE VIEWS SHOWN ABOVE ARE 1:1 SCALE AND CAN BE USED TO MATCH HARDWARE SIZES.

# KSI-356-HWR BAG BASE HARDWARE

INSTALLER NOTE: (YOU MUST ASSEMBLE THIS PRODUCT IN ACCORDANCE WITH THESE ASSEMBLY INSTRUCTIONS. WHEN COMPLETE GIVE MANUAL TO OWNER.)

N  
1/4" X 7/16" 4 Prong Tee Nut ZP  
QTY 27

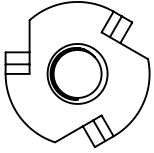

O  
3/8 x 7/16" 4 Prong Tee Nut ZP  
QTY 10

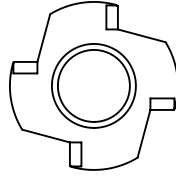

P  
3/8 Split Lockwasher ZP  
QTY 14



Q  
1/4 USS Flatwasher ZP  
QTY 93

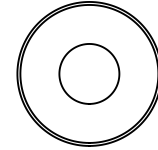

R  
3/8 USS Flatwasher ZP  
QTY 59

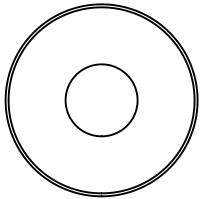

S  
5/8" Phillips Screw Snap  
QTY 9

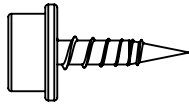

MEASUREMENT TAKEN FROM BOTTOM OF BOLT HEAD TO THE BOTTOM OF BOLT

USE A TAPE MEASURE OR RULER TO MEASURE YOUR BOLTS AND SCREWS. HARDWARE VIEWS SHOWN ABOVE ARE 1:1 SCALE AND CAN BE USED TO MATCH HARDWARE SIZES.

# 356-SB-HWR -SWINGBEAM HARDWARE

INSTALLER NOTE: (YOU MUST ASSEMBLE THIS PRODUCT IN ACCORDANCE WITH THESE ASSEMBLY INSTRUCTIONS. WHEN COMPLETE GIVE MANUAL TO OWNER.)

SB-1  
3/8" Acorn Nut Plated  
QTY 10



SB-2  
1/2" Acorn Nut Plated  
QTY 9

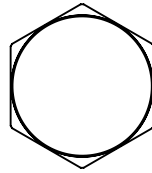

SB-3  
1/2" x 3-1/2" Carriage Bolt ZP  
QTY 2

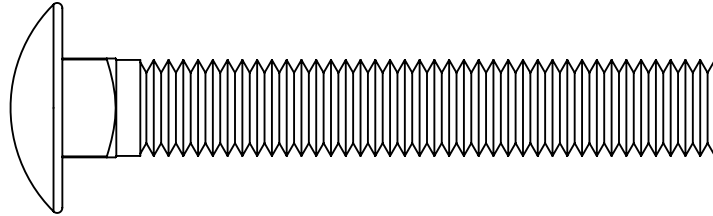

SB-6  
3/8" Hex Nut ZP  
QTY 2



SB-4  
1/2" x 7" Carriage Bolt ZP  
QTY 5

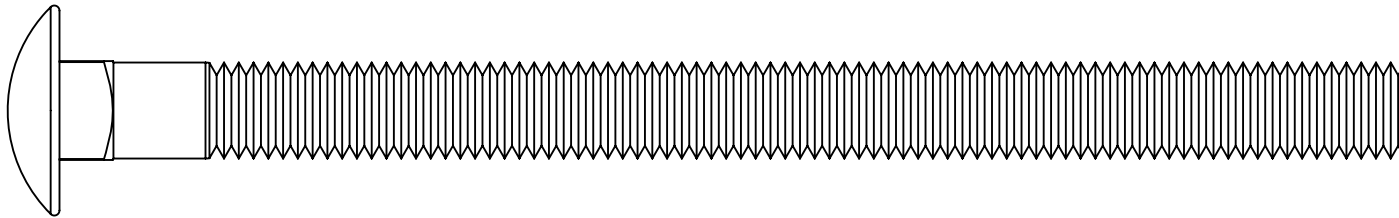

SB-7  
1/2" Hex Nut ZP  
QTY 9

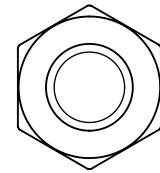

SB-5  
1/2" x 9" Carriage Bolt ZP  
QTY 1

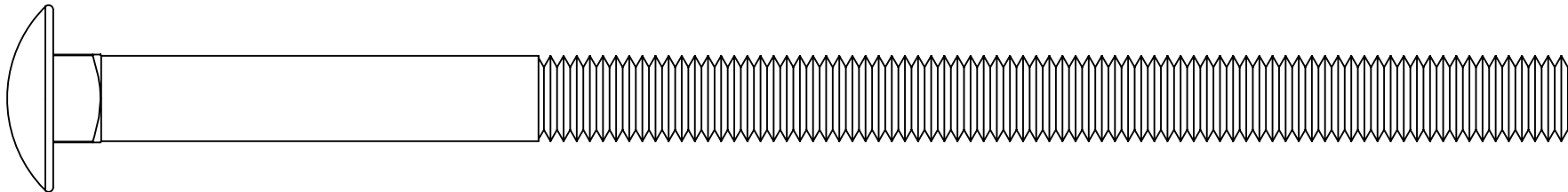

MEASUREMENT TAKEN FROM BOTTOM OF BOLT HEAD TO THE BOTTOM OF BOLT

USE A TAPE MEASURE OR RULER TO MEASURE YOUR BOLTS AND SCREWS. HARDWARE VIEWS SHOWN ABOVE ARE 1:1 SCALE AND CAN BE USED TO MATCH HARDWARE SIZES.

# 356-SB-HWR-SWINGBEAM HARDWARE

INSTALLER NOTE: (YOU MUST ASSEMBLE THIS PRODUCT IN ACCORDANCE WITH THESE ASSEMBLY INSTRUCTIONS. WHEN COMPLETE GIVE MANUAL TO OWNER.)

SB-8  
3/8" x 7" Hex Bolt ZP  
QTY 8

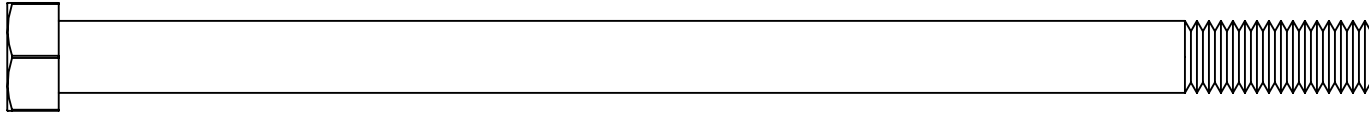

SB-9  
3/8" x 10" Hex Bolt ZP - 6" of Thread  
QTY 2

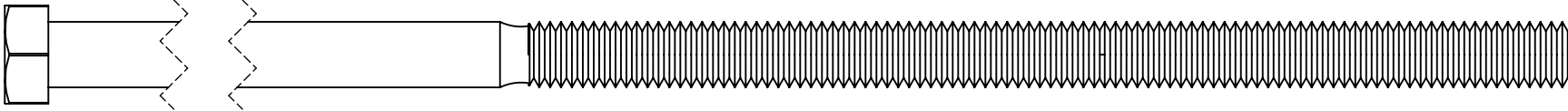

SB-10  
1/2" x 11-1/2" Hex Bolt ZP w/6" of Thread  
QTY 1

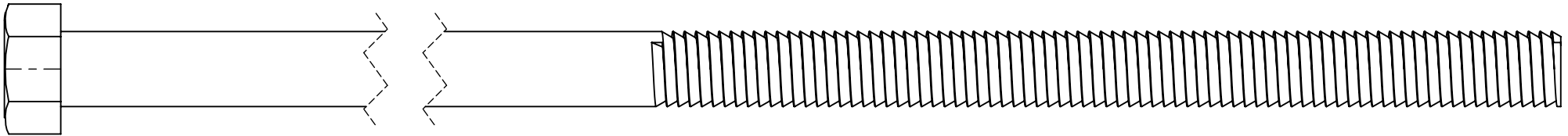

SB-11  
3/8" x 3 1/2" Hex Lag Screw ZP  
QTY 2

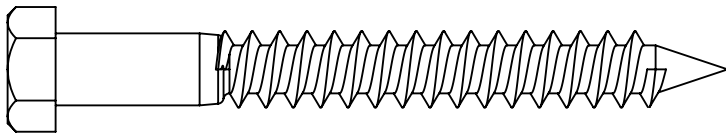

SB-12  
3/8" x 5" Hex Lag Screw ZP  
QTY 2

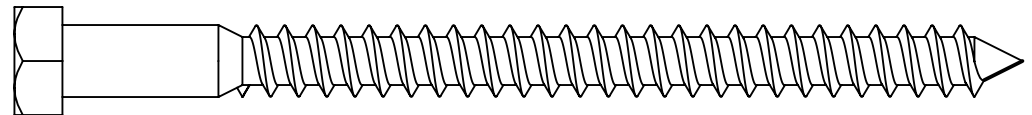

MEASUREMENT TAKEN FROM BOTTOM OF BOLT HEAD TO THE BOTTOM OF BOLT

USE A TAPE MEASURE OR RULER TO MEASURE YOUR BOLTS AND SCREWS. HARDWARE VIEWS SHOWN ABOVE ARE 1:1 SCALE AND CAN BE USED TO MATCH HARDWARE SIZES.



# 356-SB-HWR-SWINGBEAM HARDWARE

INSTALLER NOTE: (YOU MUST ASSEMBLE THIS PRODUCT IN ACCORDANCE WITH THESE ASSEMBLY INSTRUCTIONS. WHEN COMPLETE GIVE MANUAL TO OWNER.)

SB-13  
3/8" Nylon Insert Locknut NE ZP  
QTY 8



SB-14  
#14 x 1" Pan Phillips T/S ZP  
QTY 2

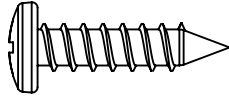

SB-15  
3/8" Split Lockwasher ZP  
QTY 10



SB-16  
1/2" Split Lockwasher ZP  
QTY 9

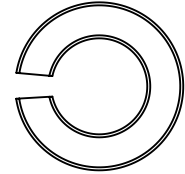

SB-17  
3/8" USS Flatwasher ZP  
QTY 14

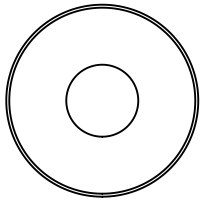

SB-19  
3/4" USS Flatwasher ZP  
QTY 8

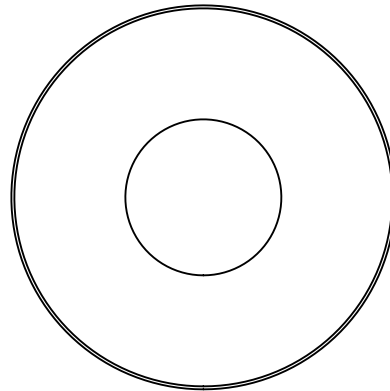

SB-20  
3/8" Bolt Cup  
QTY 10

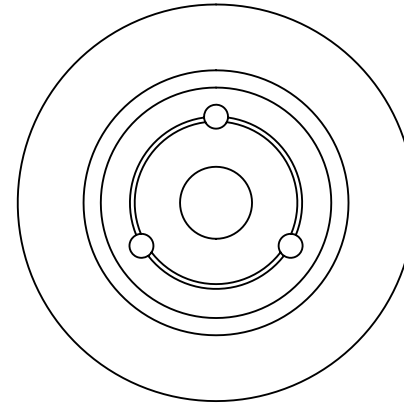

SB-21  
M8x80  
QTY 4

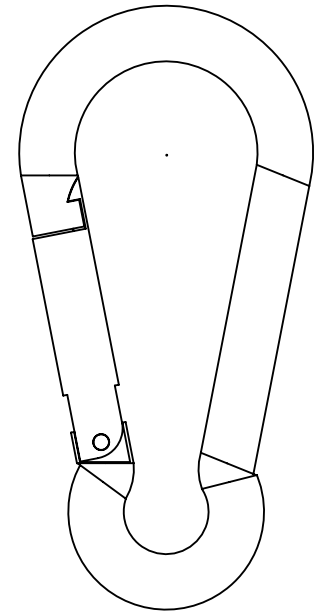

SB-18  
1/2" USS Flatwasher ZP  
QTY 10

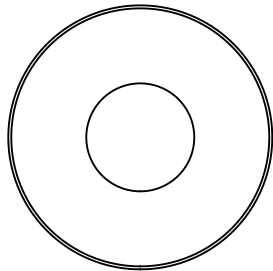

MEASUREMENT TAKEN FROM BOTTOM OF BOLT HEAD TO THE BOTTOM OF BOLT

USE A TAPE MEASURE OR RULER TO MEASURE YOUR BOLTS AND SCREWS. HARDWARE VIEWS SHOWN ABOVE ARE 1:1 SCALE AND CAN BE USED TO MATCH HARDWARE SIZES.

# 353-HWR-WOOD ROOF HARDWARE

INSTALLER NOTE: (YOU MUST ASSEMBLE THIS PRODUCT IN ACCORDANCE WITH THESE ASSEMBLY INSTRUCTIONS. WHEN COMPLETE GIVE MANUAL TO OWNER.)

WR-1  
#8 x 1-1/4" Coated Deck Screw  
QTY 30

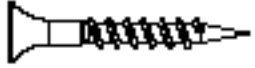

WR-2  
#8 x 1-1/2" Coated Deck Screw  
QTY 152



WR-3  
#8 x 2" Coated Deck Screw  
QTY 6

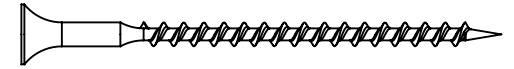

WR-4  
#8 x 2-1/2" Coated Deck Screw  
QTY 10



WR-5  
3/8" x 3 1/2" Hex Lag Screw ZP  
QTY 4

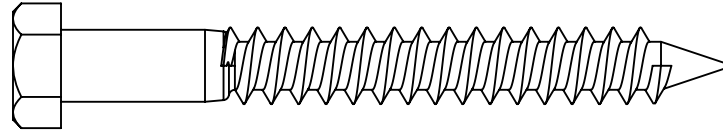

WR-6  
3/8 USS Flatwasher ZP  
QTY 4

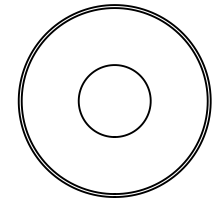

WR-7  
#2 & #3  
QTY 1



MEASUREMENT TAKEN FROM BOTTOM OF BOLT HEAD TO THE BOTTOM OF BOLT

USE A TAPE MEASURE OR RULER TO MEASURE YOUR BOLTS AND SCREWS. HARDWARE VIEWS SHOWN ABOVE ARE 1:1 SCALE AND CAN BE USED TO MATCH HARDWARE SIZES.

# 354-HWR-TREE HOUSE HARDWARE

INSTALLER NOTE: (YOU MUST ASSEMBLE THIS PRODUCT IN ACCORDANCE WITH THESE ASSEMBLY INSTRUCTIONS. WHEN COMPLETE GIVE MANUAL TO OWNER.)

TH-1  
#8 x 1-1/2" Coated Deck Screw  
QTY 328

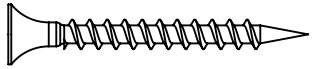









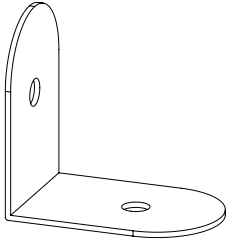
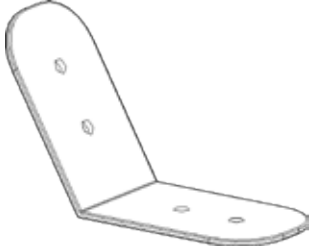
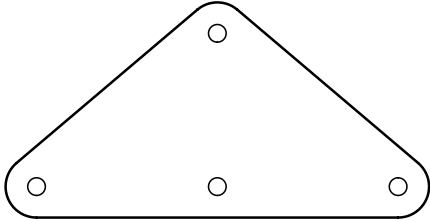
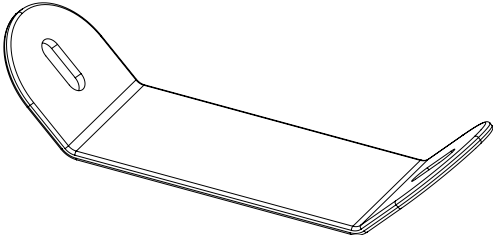

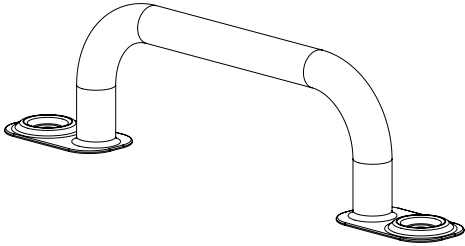
TH-2  
#2 & #3  
QTY 1





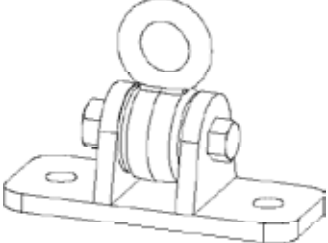

MEASUREMENT TAKEN FROM BOTTOM OF BOLT HEAD TO THE BOTTOM OF BOLT

USE A TAPE MEASURE OR RULER TO MEASURE YOUR BOLTS AND SCREWS. HARDWARE VIEWS SHOWN ABOVE ARE 1:1 SCALE AND CAN BE USED TO MATCH HARDWARE SIZES.

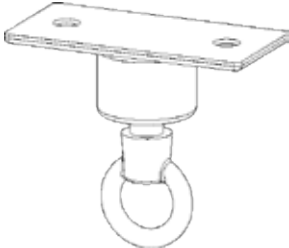
Picture	Description	QTY.
	<p>356-A 90 Degree Bracket</p>	<p>2</p>
	<p>356-B 120° Bracket</p>	<p>2</p>
	<p>356-C Swing Beam Tri Plate</p>	<p>1</p>
	<p>356-D Swingbeam 45 Degree Bracket</p>	<p>2</p>
	<p>356-E 1-1/4" x 22 1/4" PlayGrip Tube</p>	<p>4</p>
	<p>356-F PlayGrip Safety Handle</p>	<p>4</p>
	<p>356-G PlayGrip Ladder Handle</p>	<p>3</p>

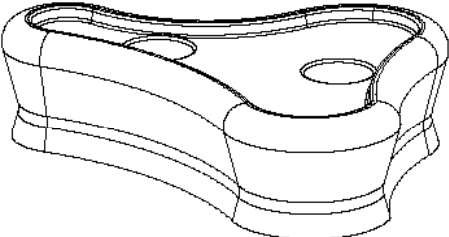
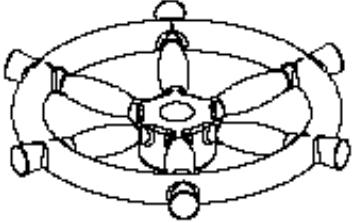
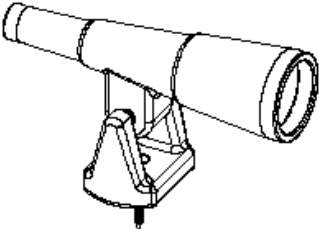
Picture	Description	QTY.
	<p>356-H 14' Yellow Rope w/ Rope Caps</p>	<p>2</p>
	<p>356-I 17' Yellow Rope w/ Rope Caps</p>	<p>3</p>
	<p>356-J 16" Trapeze Bar w/ Rings</p>	<p>1</p>
	<p>356-K 36" Plastisol Coated Chain</p>	<p>3</p>
	<p>356-L Disk Swing</p>	<p>1</p>
	<p>356-M Tic Tac Toe Set</p>	<p>1</p>
	<p>356-N Ductile Iron Swing Hanger</p>	<p>6</p>

Picture	Description	QTY.
	<p>356-O Tire Swing Eye Bolt</p>	<p>3</p>
	<p>356-P Bull Ring Tire Swivel</p>	<p>1</p>
	<p>356-Q 66" Chained Belt Swing</p>	<p>2</p>
	<p>356-R Rockwall Rocks</p>	<p>12</p>
	<p>356-S Ships' Wheel</p>	<p>1</p>
	<p>356-T Telescope</p>	<p>1</p>
	<p>356-U Spiral Ground Anchor</p>	<p>4</p>

# Pipe/ Step Ladder Assembly

## PARTS NEEDED

- 356-29- 80" (L) Step Ladder Leg- (1)
- 356-18- 21 9/16" Ladder Step- (4)
- 356-25- 65" Center Pipe & Step Ladder Leg- (1)
- 356-E- 1 1/4" x 22 1/4" Playgrip Tube- (4)
- 356-28- 80" (R) Pipe Ladder Leg- (1)

## HARDWARE NEEDED

- G- 1/4" x 4 1/2" Hex Lag Screw- (16)
- Q- 1/4" USS Flatwasher- (16)
- M- 2" Metal Tap Screw- (8)

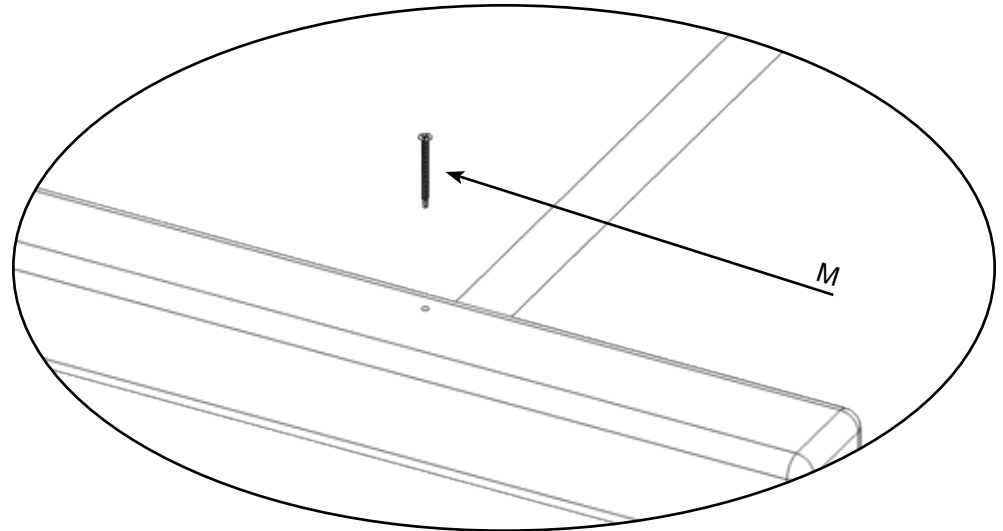
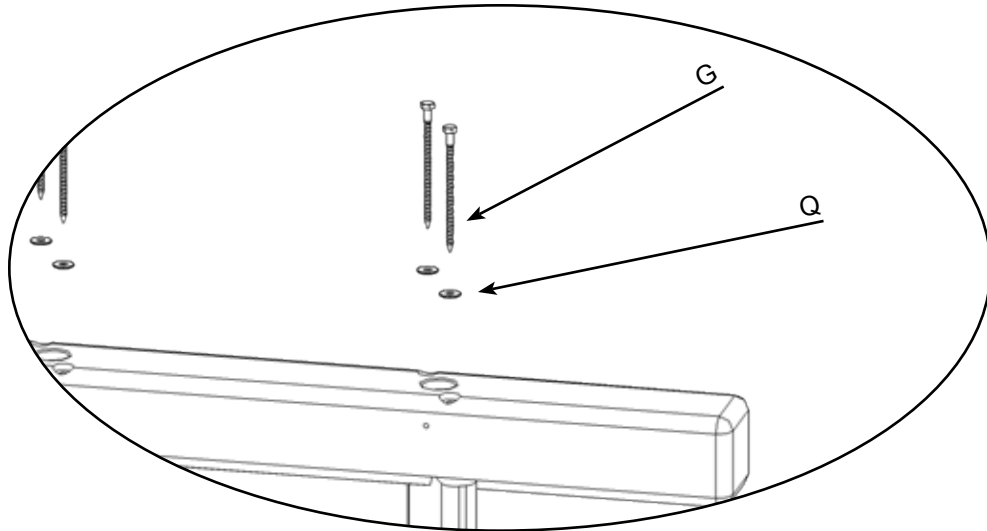
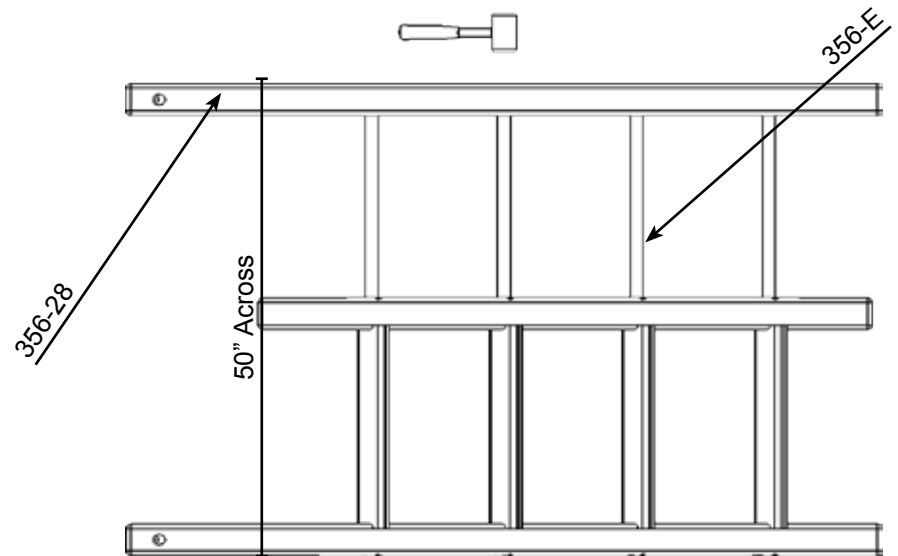
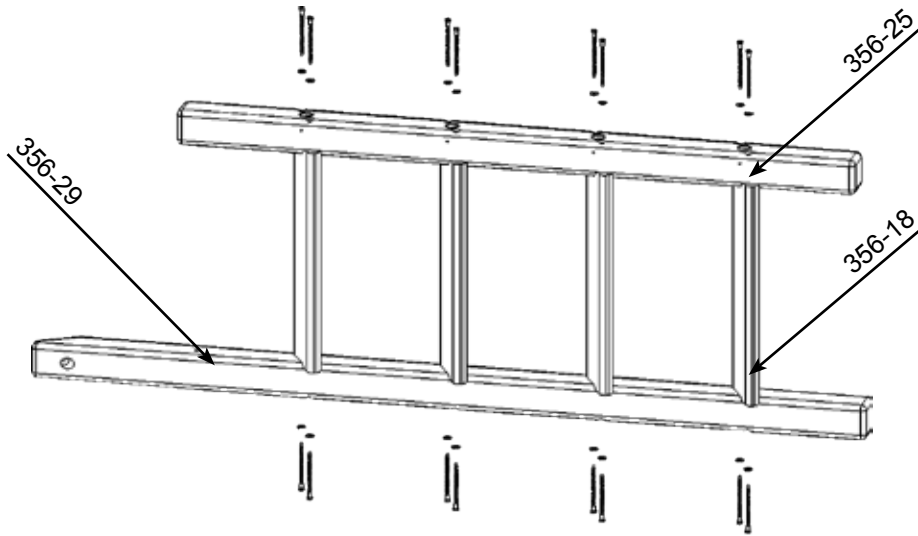

# Pipe/ Step Ladder Assembly

## PARTS NEEDED

- 356-32- 94 1/8" Rope Ladder Runner- (1)
- 356-21- (L) Gusset- (1)
- 356-22- (R) Gusset- (1)

## HARDWARE NEEDED

- I- 3/8" x 5" Hex Lag Screw- (3)
- R- 3/8" USS Flatwasher- (7)
- H- 3/8" x 3 1/2" Hex Lag Screw- (4)

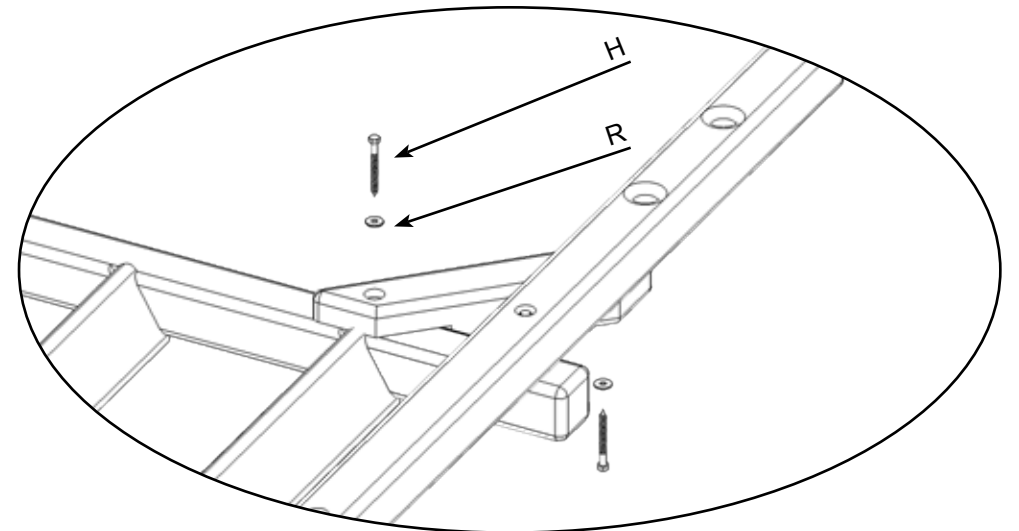
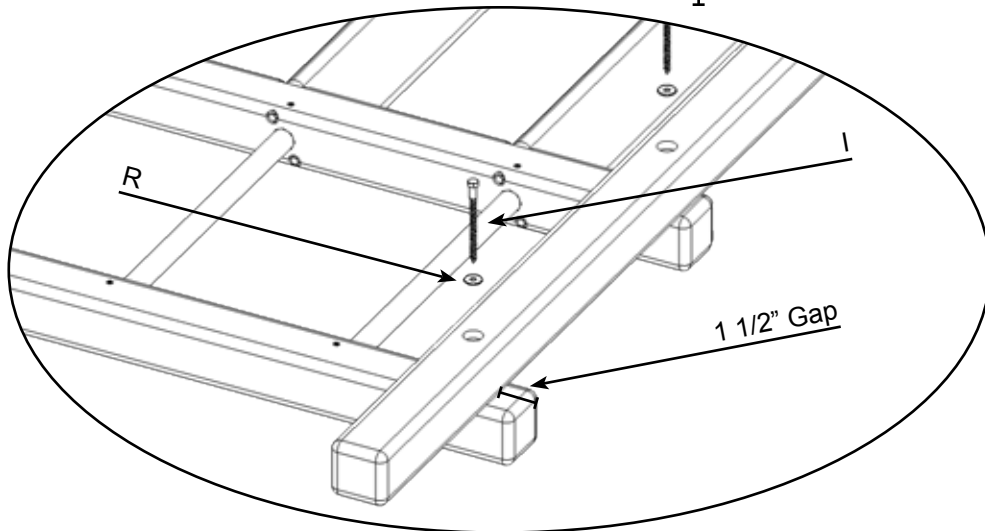
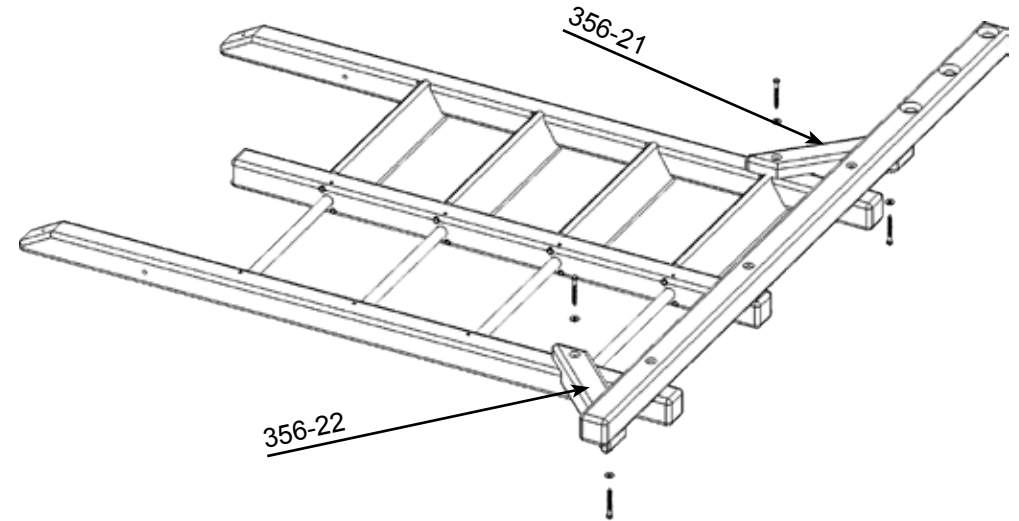
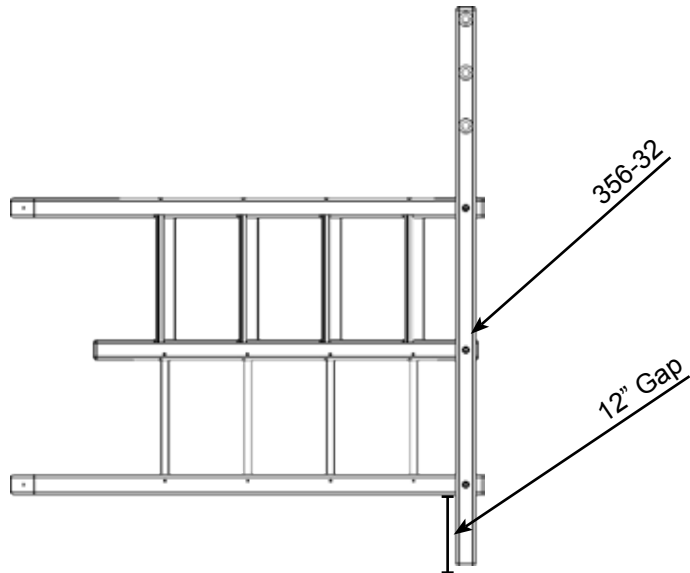



# Pipe/ Step Ladder Assembly

## PARTS NEEDED

- |  |     |
|--|-----|
| 356-G- Playgrip Ladder Handle-           | (3) |
| 356-14- 50" Rockwall Board w/ Rope Hole- | (1) |
| 356-11- 50" 1- Rock Rockwall Board-      | (5) |
| 356-12- 50" 2- Hole Rockwall Board-      | (3) |

# Rockwall Board Assemblies

## HARDWARE NEEDED

- |                                    |      |
|------------------------------------|------|
| K- #14 x 2" Pan Phillips T/S-      | (6)  |
| Q- 1/4" USS Flatwasher-            | (30) |
| L- 1/4" x 1 1/4" Pan Phillips M/S- | (24) |
| N- 1/4" T-Nut-                     | (24) |

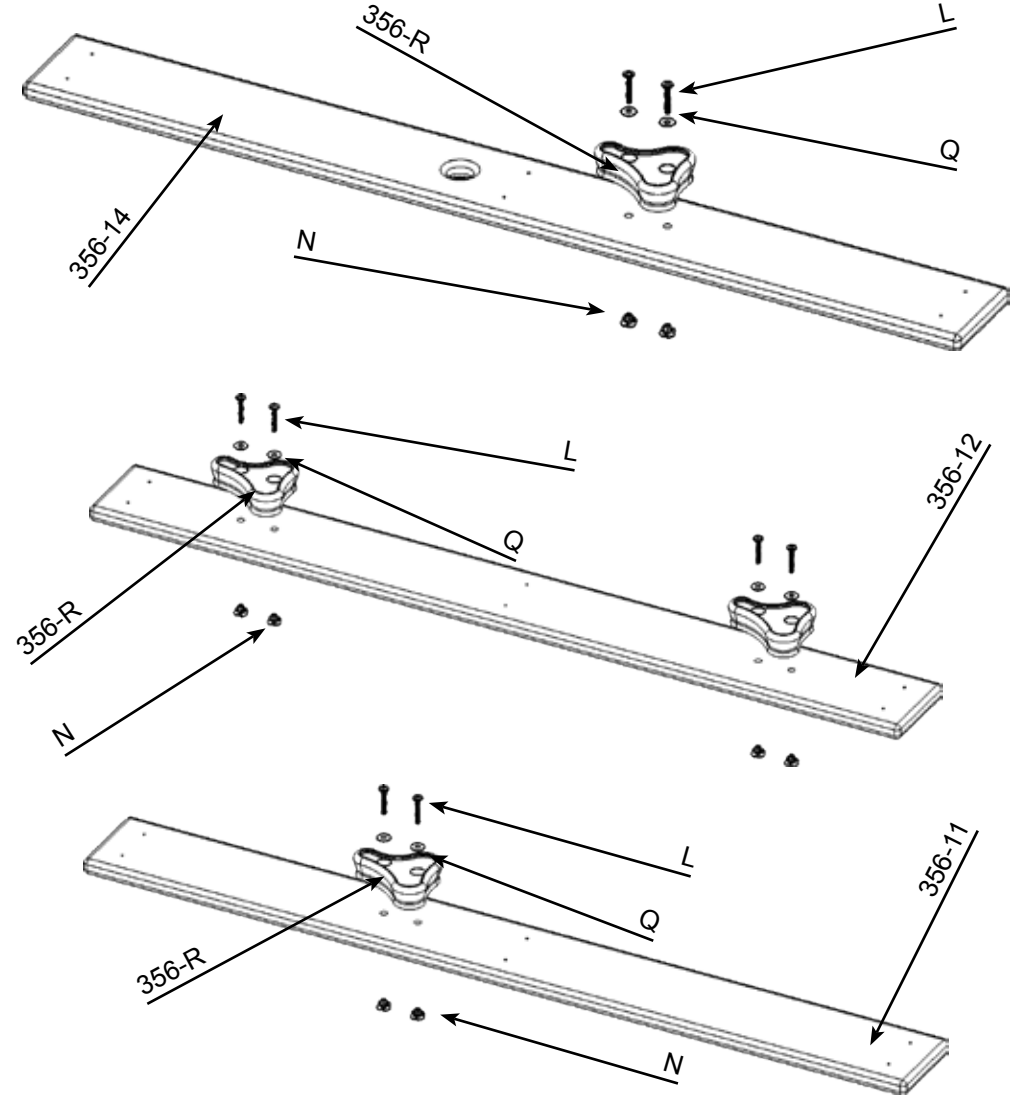
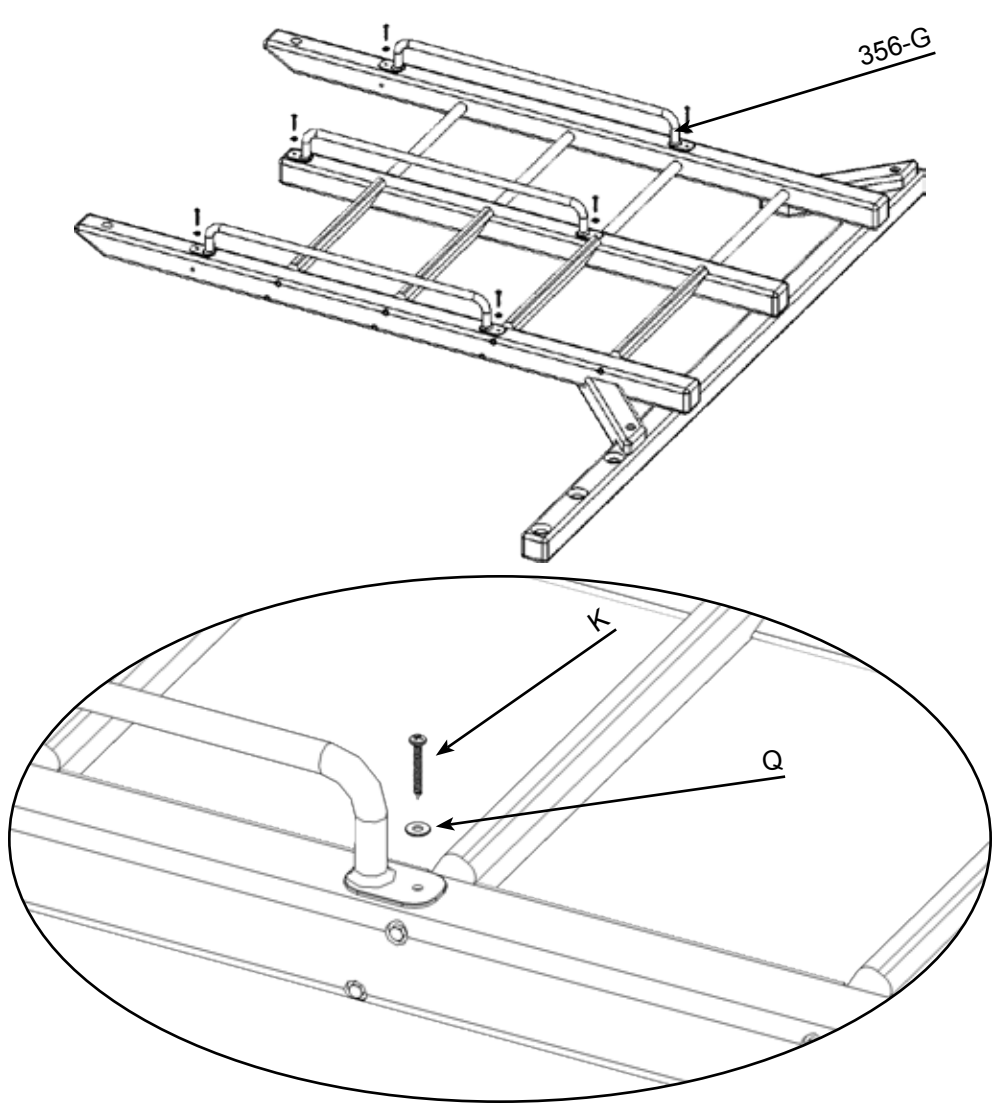

# Rockwall Assembly

## PARTS NEEDED

356-27- 80" Rockwall Ladder Leg-	(2)
356-11- 50" 1- Rock Rockwall Board-	(5)
356-12- 50" 2- Rock Rockwall Board-	(3)
356-13- 50" Blank Rockwall Board-	(3)
356-14- 50" Rockwall Board w/ Rope Hole-	(1)
356-26- 74" Ground Runner-	(1)

## HARDWARE NEEDED

D- 2 1/2" Coated Deck Screw-	(48)
L- 3/8" x 5" Hex Lag Screw-	(2)
R- 3/8" USS Flatwasher-	(2)

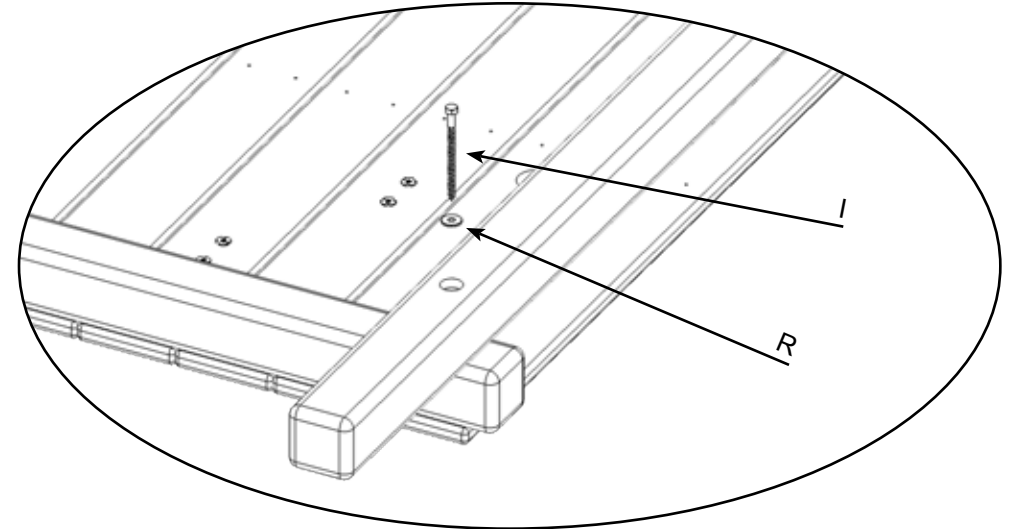
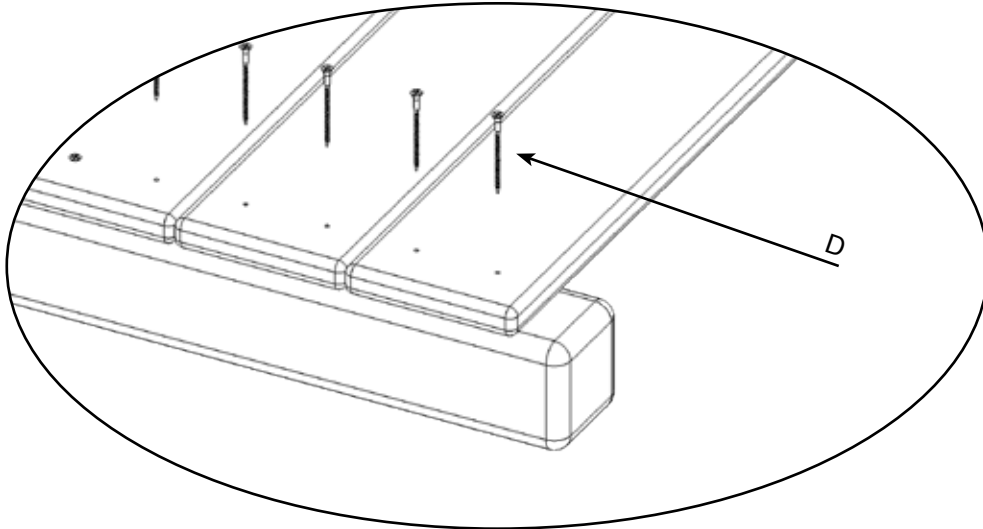
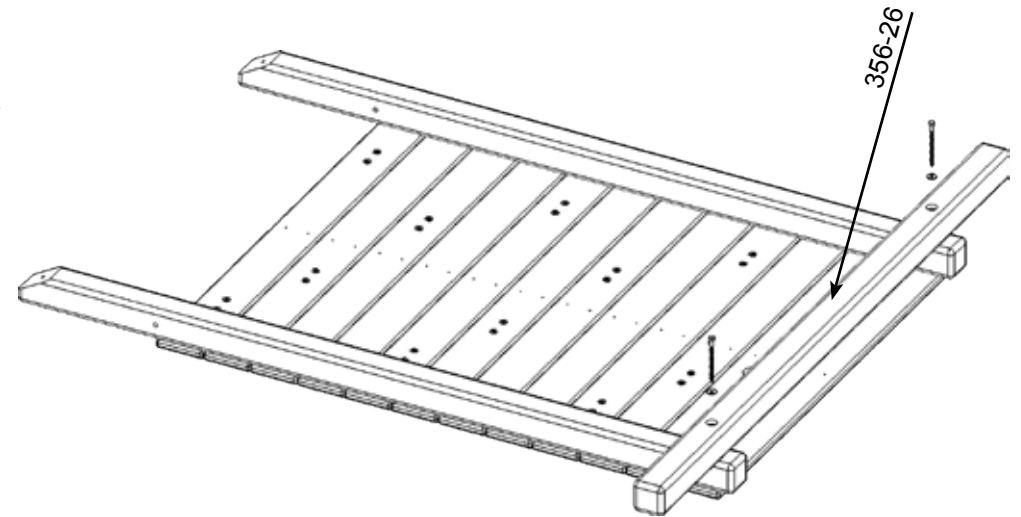
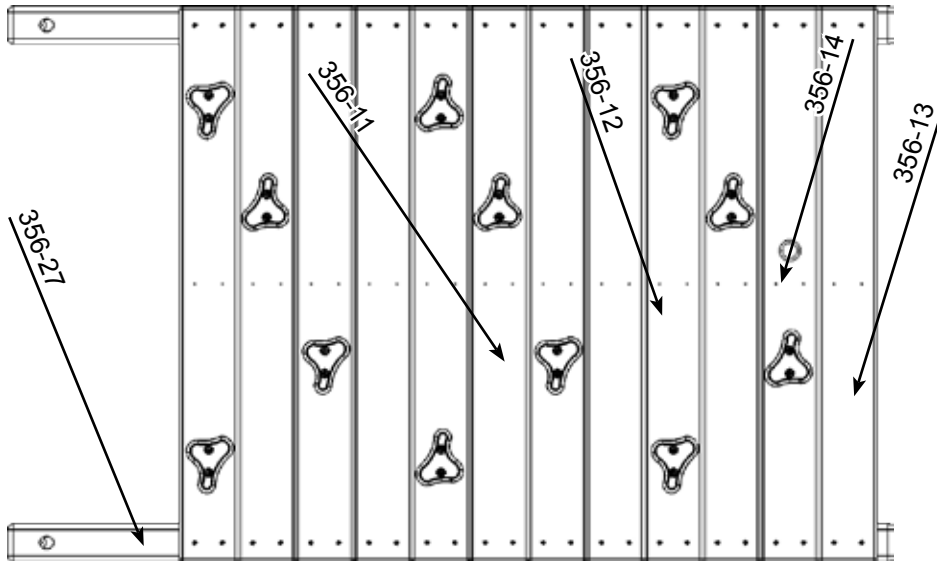

# Rockwall Assembly

## PARTS NEEDED

- 356-21- 19" Left Gusset- (1)
- 356-22- 19" Right Gusset- (1)
- 356-8- 63" Rockwall Support- (1)

## HARDWARE NEEDED

- H- 3/8" x 3 1/2" Hex Lag Screw- (4)
- R- 3/8" USS Flatwasher- (4)
- B- 1 1/2" Coated Deck Screw- (24)

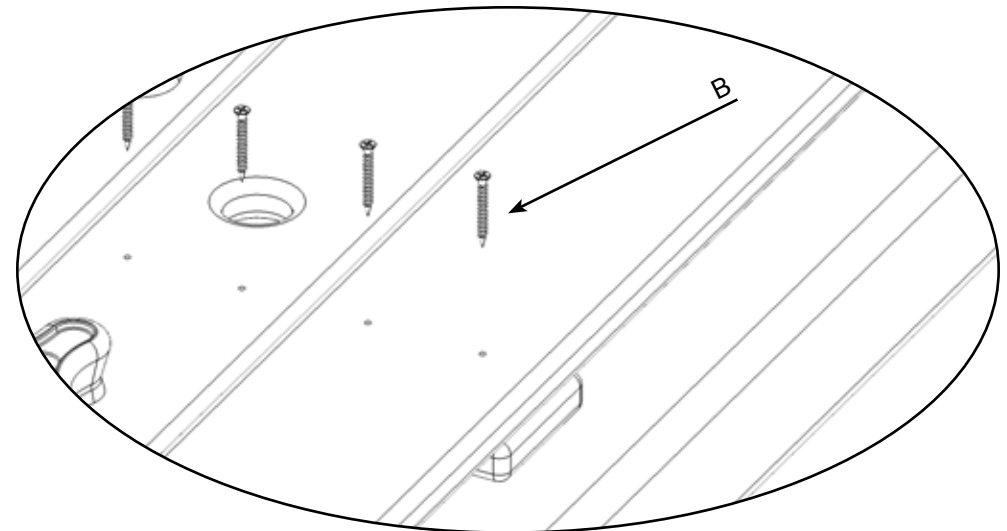
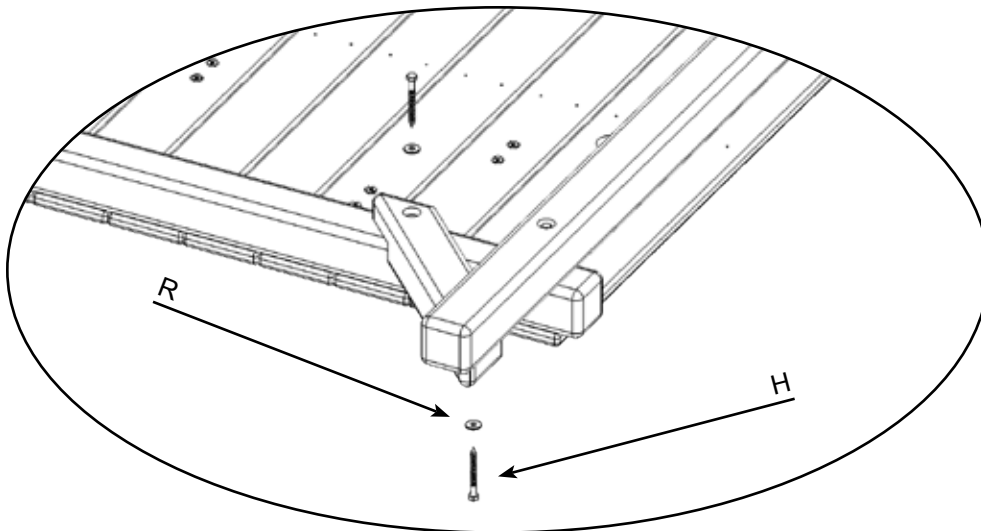
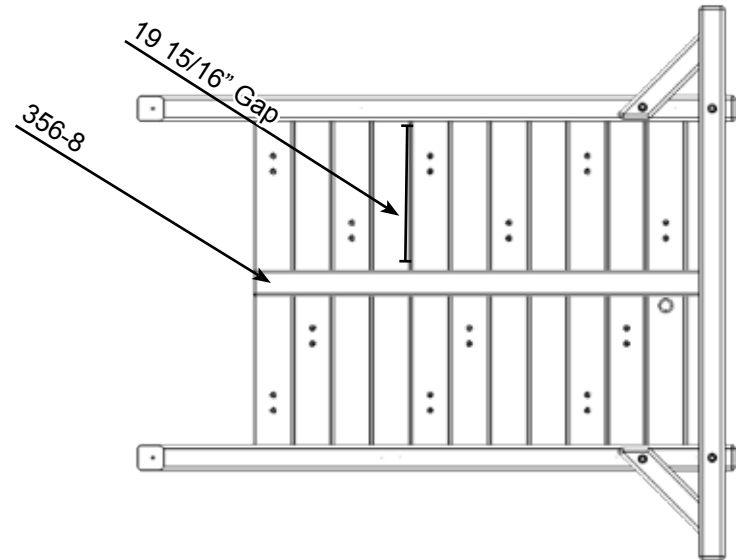
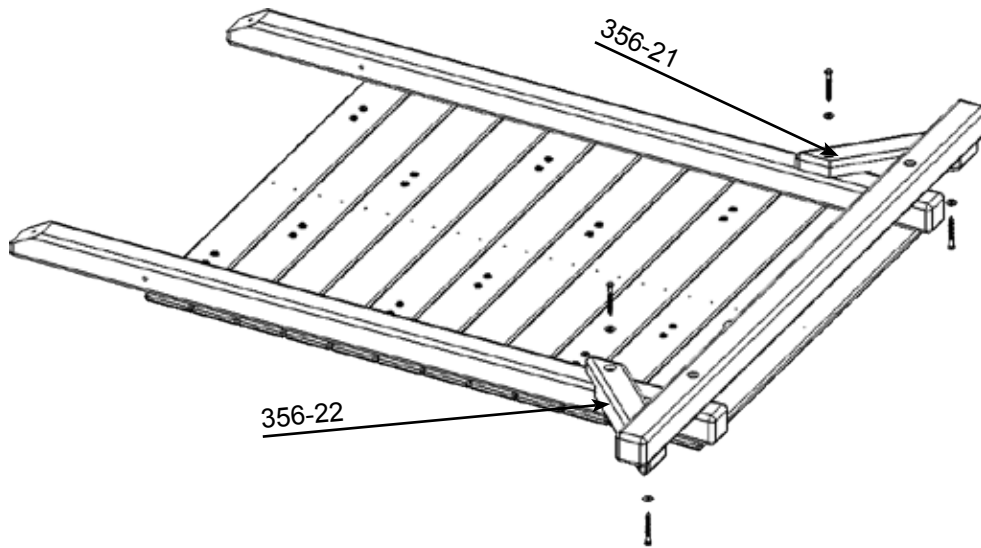

# A-Frame Assembly

## PARTS NEEDED

- 356-35- 7 5/8" Center A-Frame Block- (1)
- 356-36- 12 7/8" A-Frame Block- (1)
- 356-37- 12 7/8" A-Frame Block Sunked- (1)
- 356-40- 125" Universal Swingbeam- (1)

## HARDWARE NEEDED

- SB-9- 3/8" x 9" Hex Bolt- (1)
- SB-17- 3/8" USS Flatwasher- (9)
- SB-1- 3/8" Acorn Nut Plated- (9)
- SB-13- 3/8" Nylon Insert Locknut- (8)
- SB-20- 3/8" Bolt Cup- (9)
- SB-6- 3/8" Hex Nut- (1)
- SB-8- 3/8" x 7" Hex Bolt- (8)

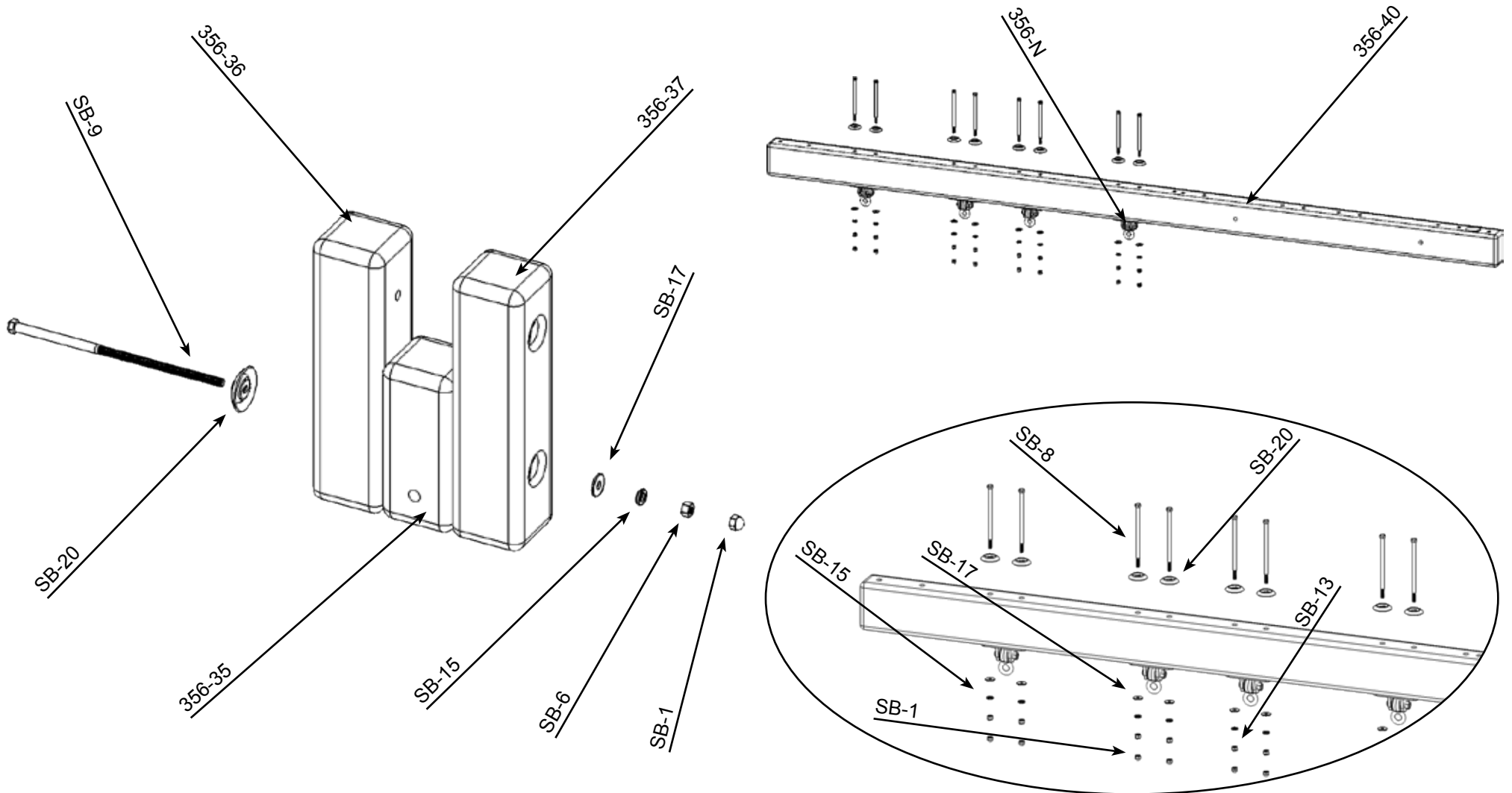

# A-Frame Assembly

## PARTS NEEDED

Beam Assembly- (1)  
 Block Assembly- (1)  
 356-39- 113" A-Frame Ladder Leg- (2)  
 356-D- Swingbeam 45 Degree Bracket- (2)

SB-9- 3/8" x 9" Hex Lag Screw- (1)  
 SB-17- 3/8" USS Flatwasher- (1)  
 SB-6- 3/8" Hex Nut- (1)  
 SB-10- 1/2" x 10 1/2" Hex Bolt- (1)  
 SB-16- 1/2" Split Lockwasher- (1)

## HARDWARE NEEDED

SB-20- 3/8" Bolt Cup- (1)  
 SB-15- 3/8" Split Lockwasher- (1)  
 SB-1- 3/8" Acorn Nut Plated- (1)  
 SB-18- 1/2" USS Flatwasher- (2)  
 SB-2- 1/2" Acorn Nut Plated- (1)

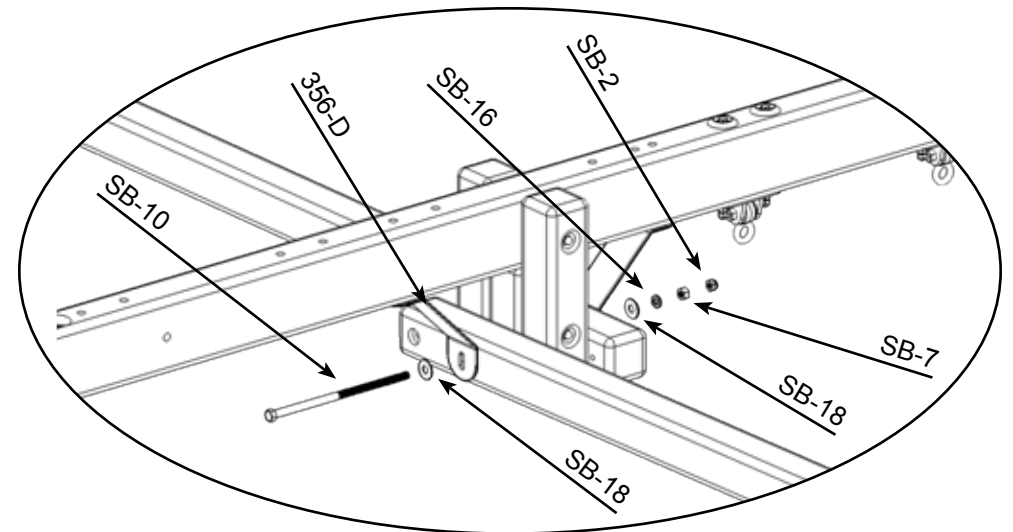
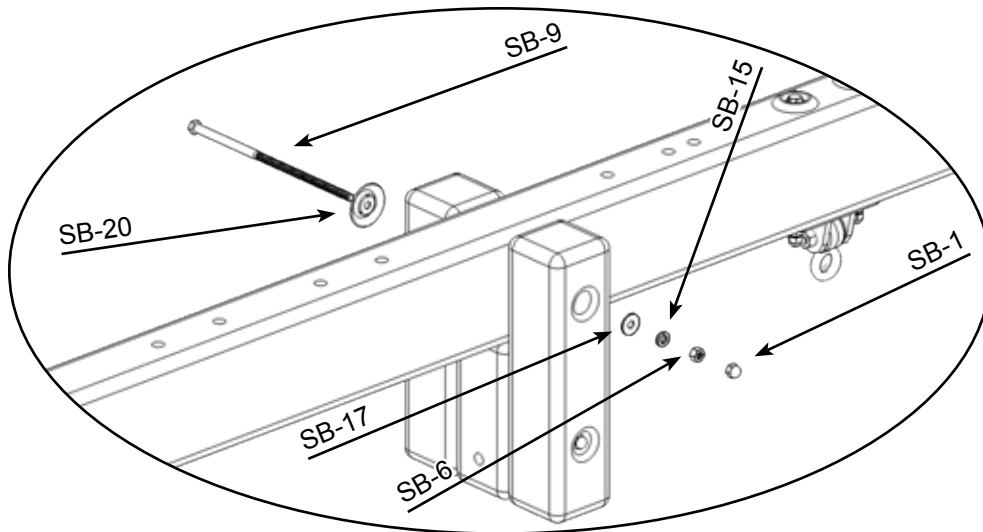
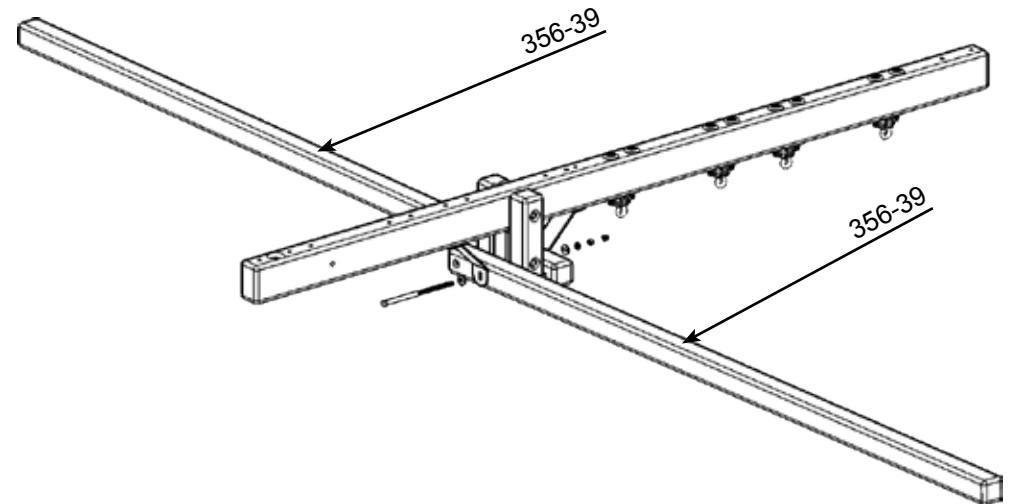
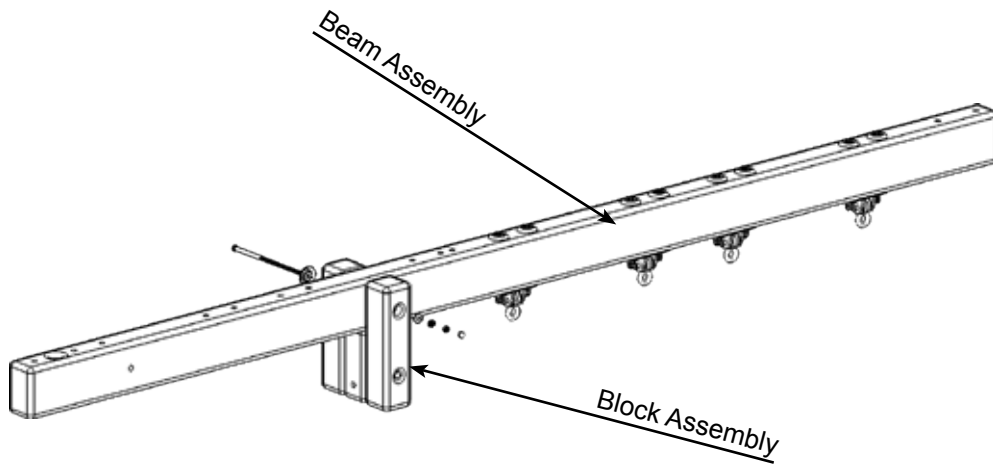

# A-Frame Assembly

## PARTS NEEDED

356-K- 36" Plastisol Coated Chain- (3)  
 356-O- Tire Swing Eye Bolt- (3)  
 Tire- (1)

SB-4- 1/2" x 7" Carriage Bolt- (2)  
 SB-18- 1/2" USS Flatwasher- (2)  
 SB-7- 1/2" Hex Nut- (1)

# Tire Swing Assembly

## HARDWARE NEEDED

(2) SB-19- 3/4" USS Flatwasher- (2)  
 (2) SB-16- 1/2" Split Lockwasher- (2)  
 (2) SB-2- 1/2" Acorn Nut Plated- (2)

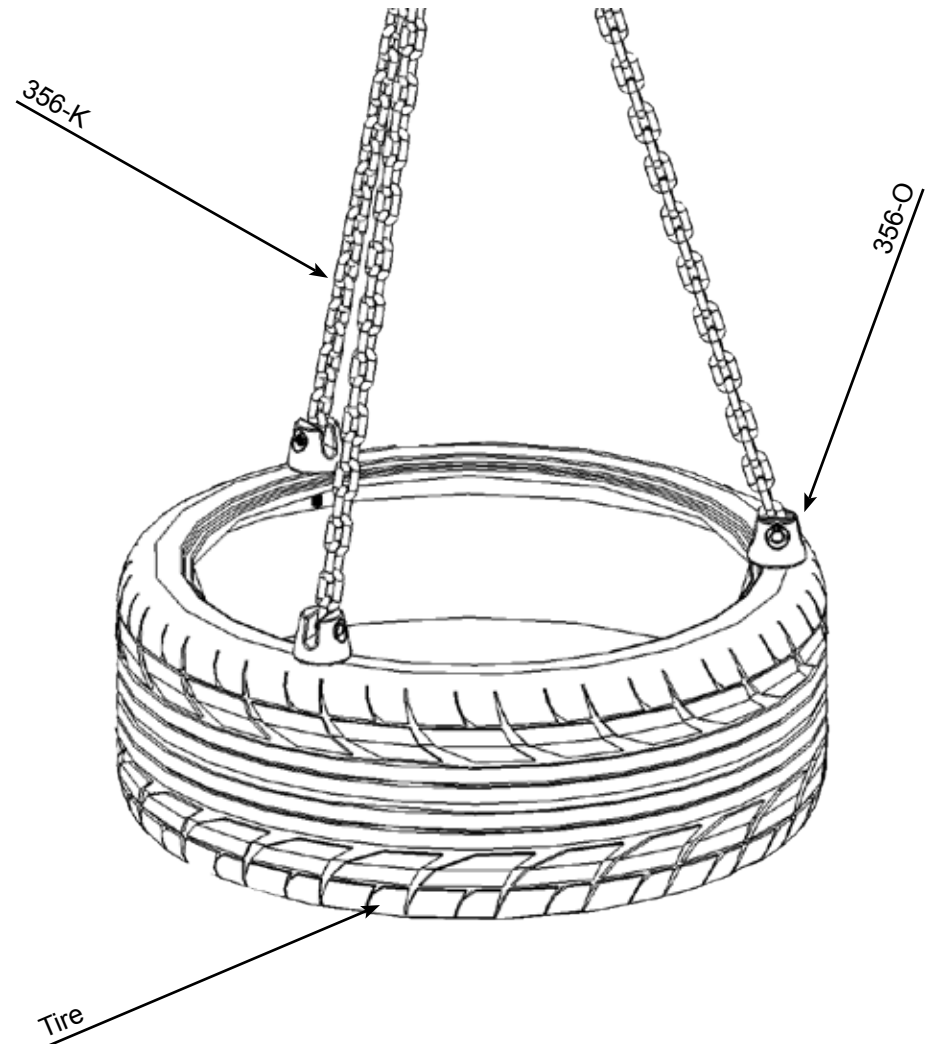
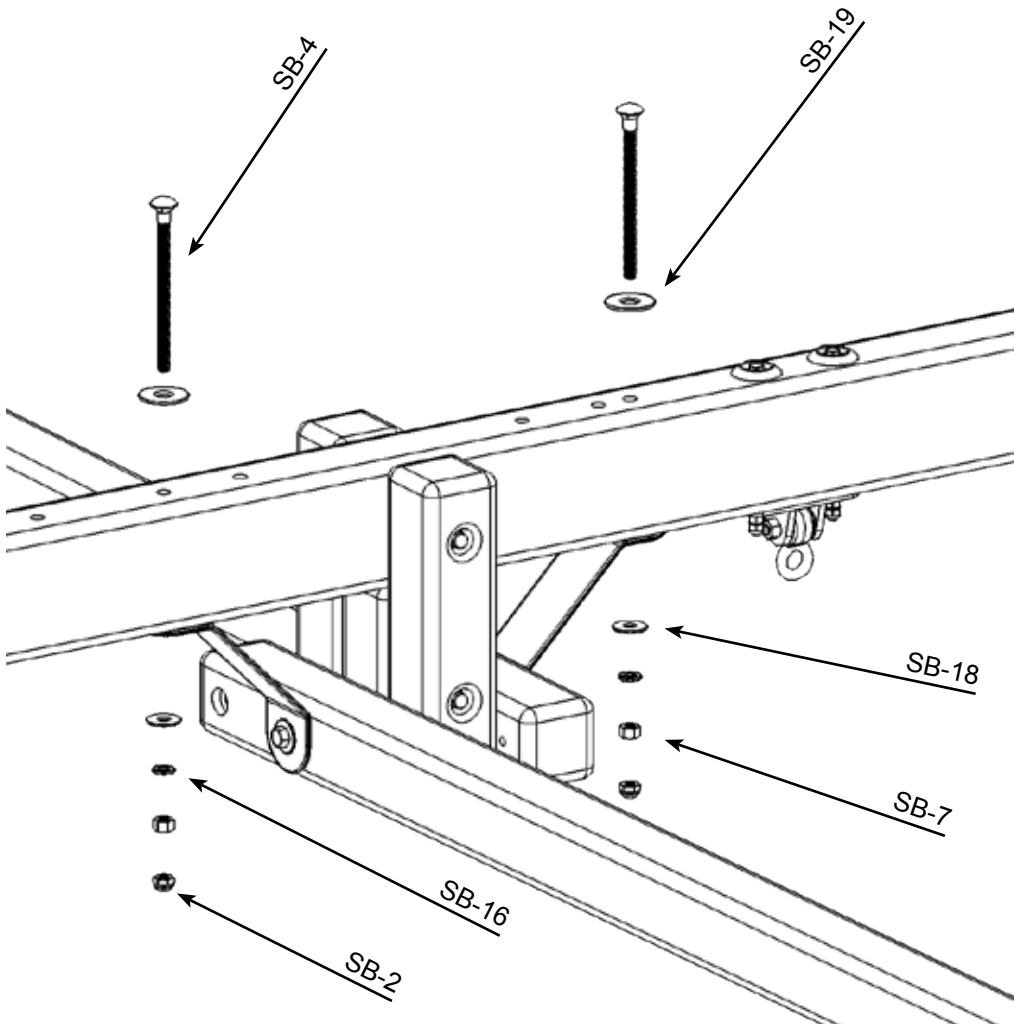

# Main Assembly

## PARTS NEEDED

356-19- 83 1/8" Main Beam- (4)

A-5- 3/8" x 6" Hex Bolt-  
 O- 3/8" T-Nut-  
 Q- 1/4" USS Flatwasher-

## HARDWARE NEEDED

(4) R- 3/8" USS Flatwasher- (4)  
 (4) A-1- 3/8" Acorn Nut Plated- (4)  
 (8) F- 1/4" x 3" Hex Lag Screw- (4)

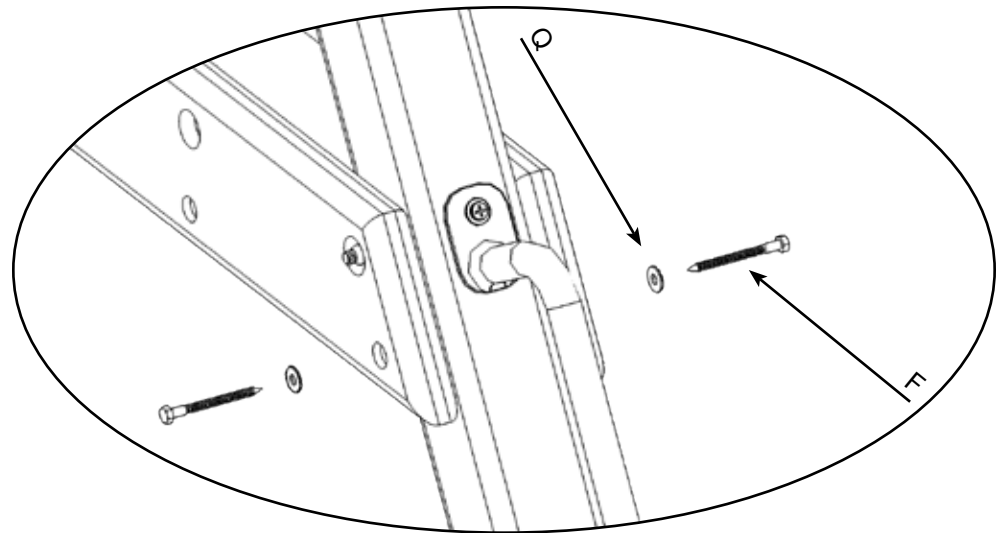
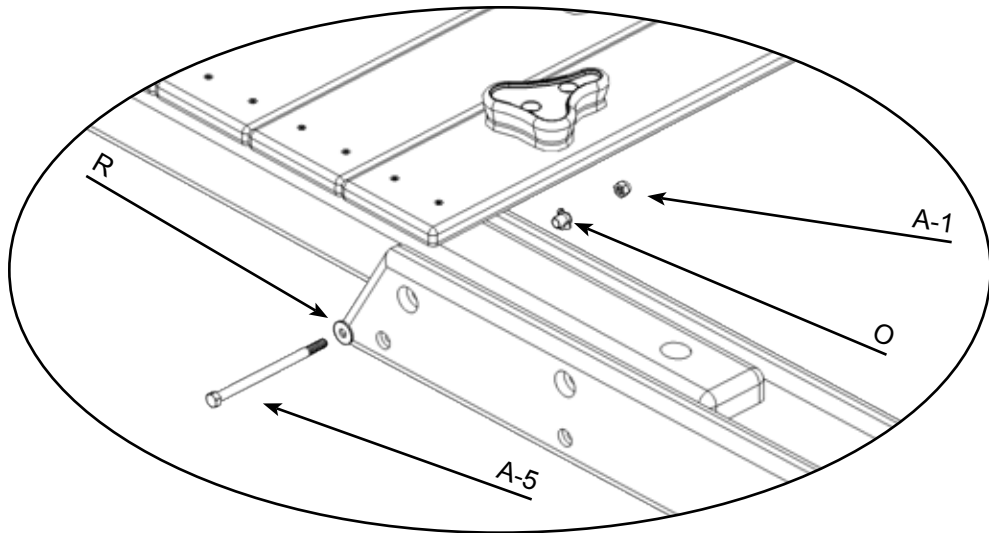
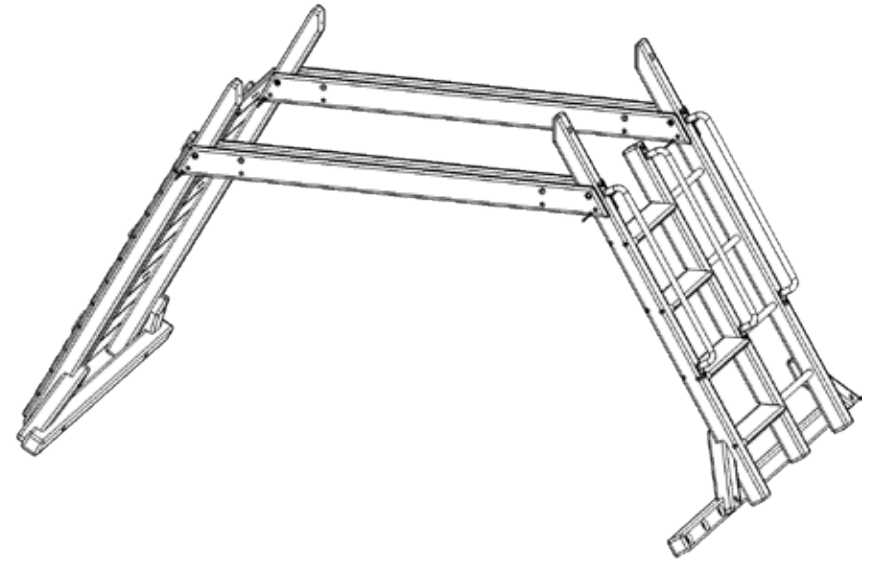
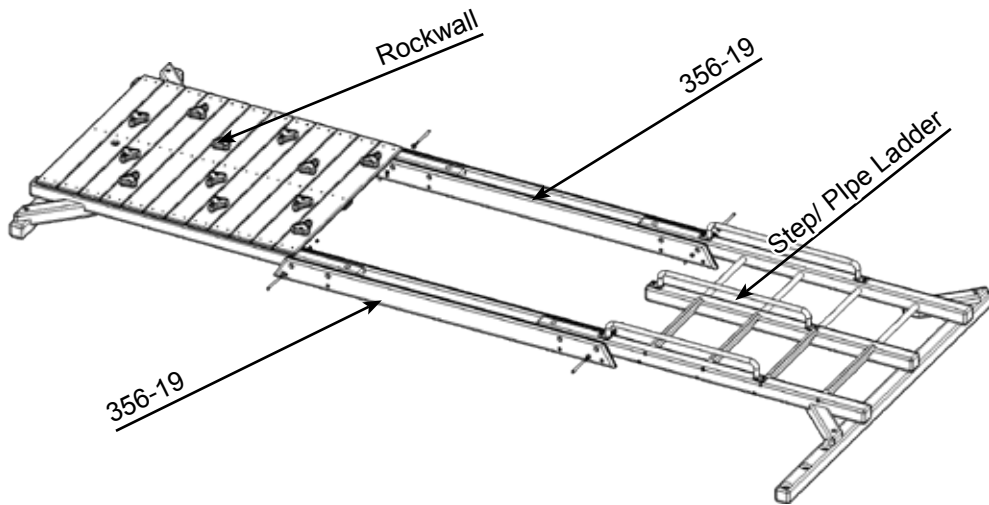

# Main Assembly

## PARTS NEEDED

356-9- 43 1/4" Short Deck Board- (4)

## HARDWARE NEEDED

R- 3/8" USS Flatwasher- (4)

I- 3/8" x 5" Hex Lag Screw- (4)

C- 2" Coated Deck Screw- (16)

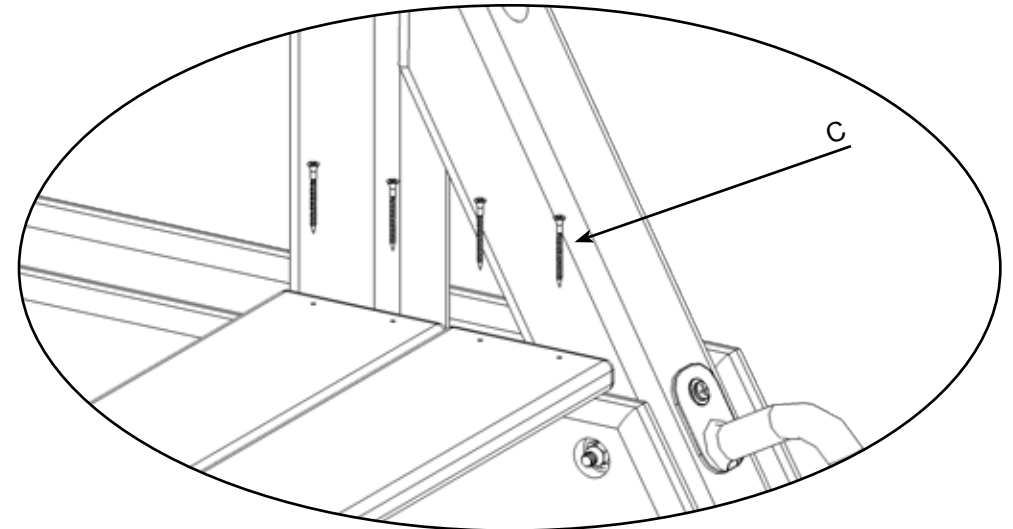
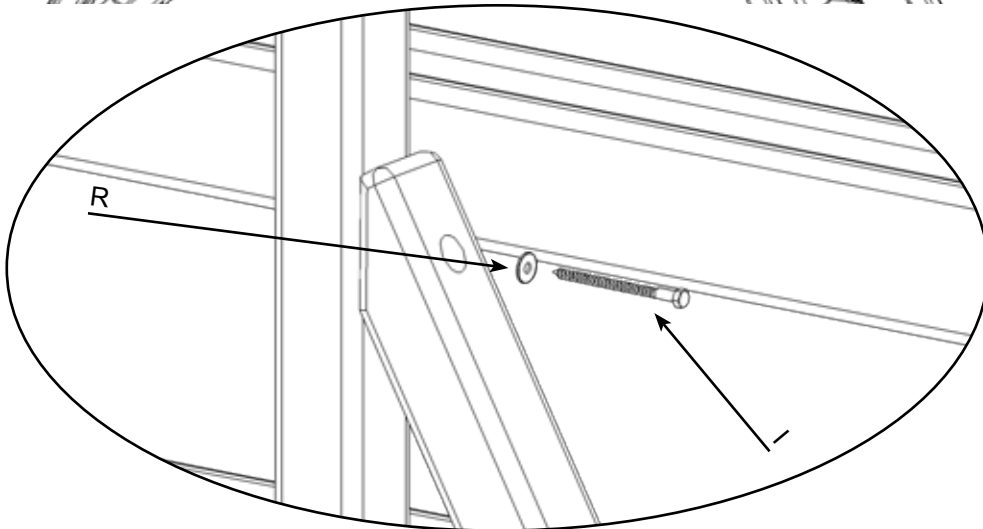
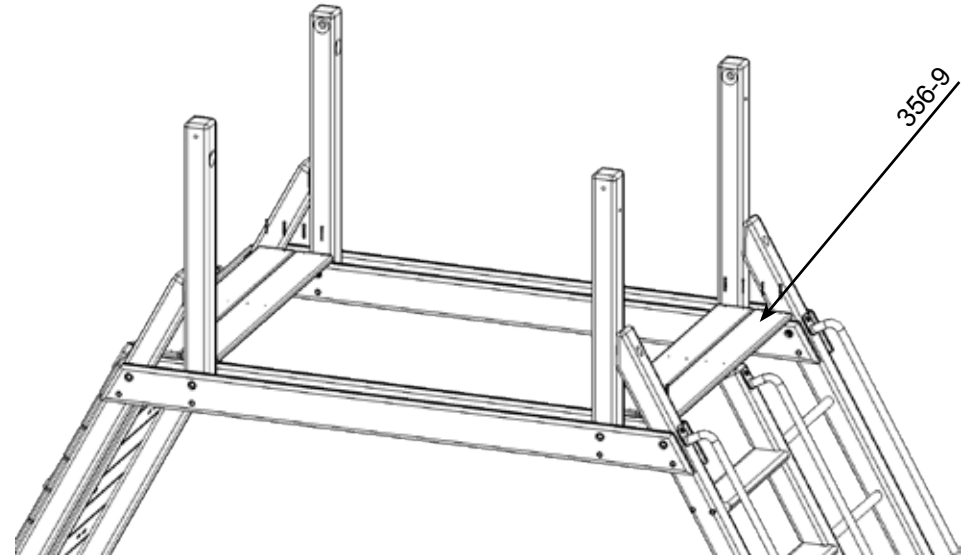
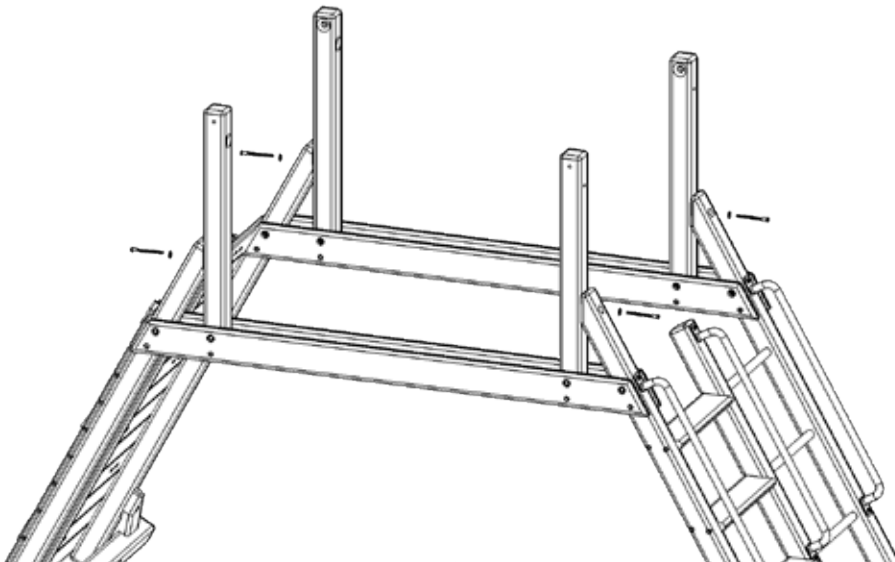



# Main Assembly

## PARTS NEEDED

356-10- 50" Deck Board-	(10)
356-15- 74 3/4" Deck Support-	(1)
356-B- 120 Degree Bracket-	(2)

## HARDWARE NEEDED

C- 2" Coated Deck Screw-	(40)
Q- 1/4" USS Flatwasher-	(8)
J- #14 x 1" Pan Phillips T/S-	(8)
B- 1 1/2" Coated Deck Screw-	(28)

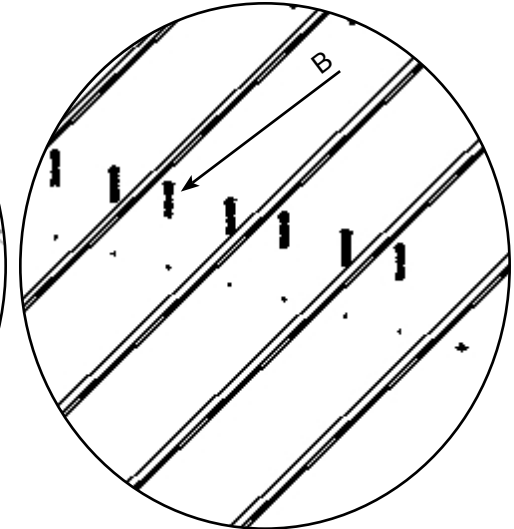
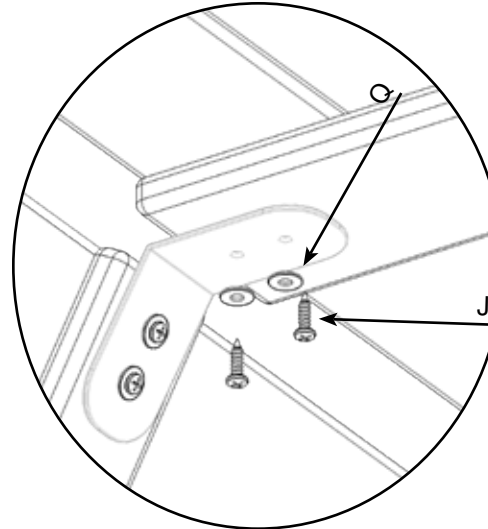
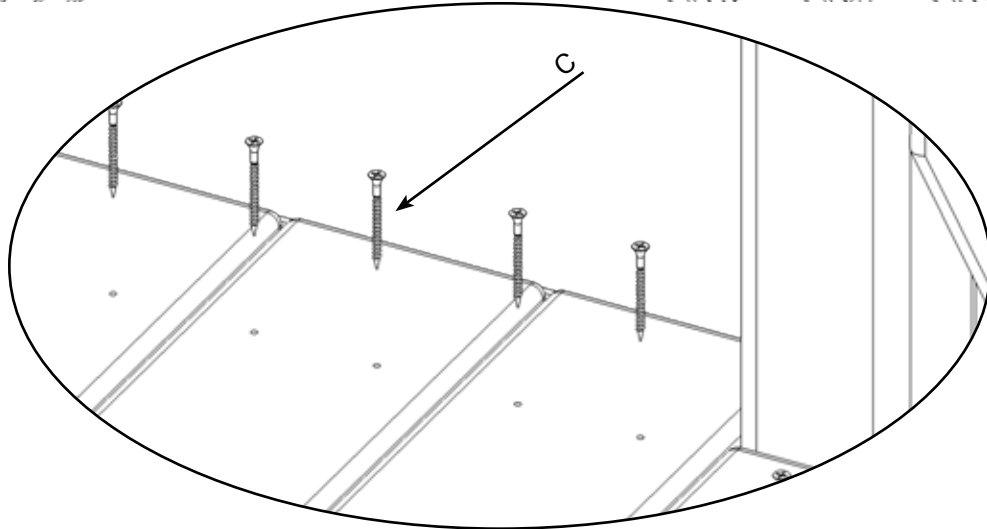
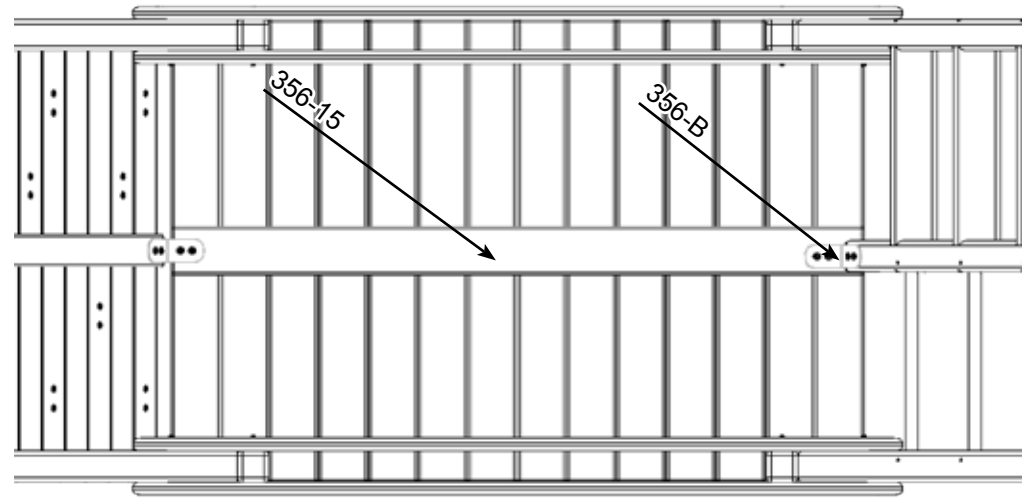
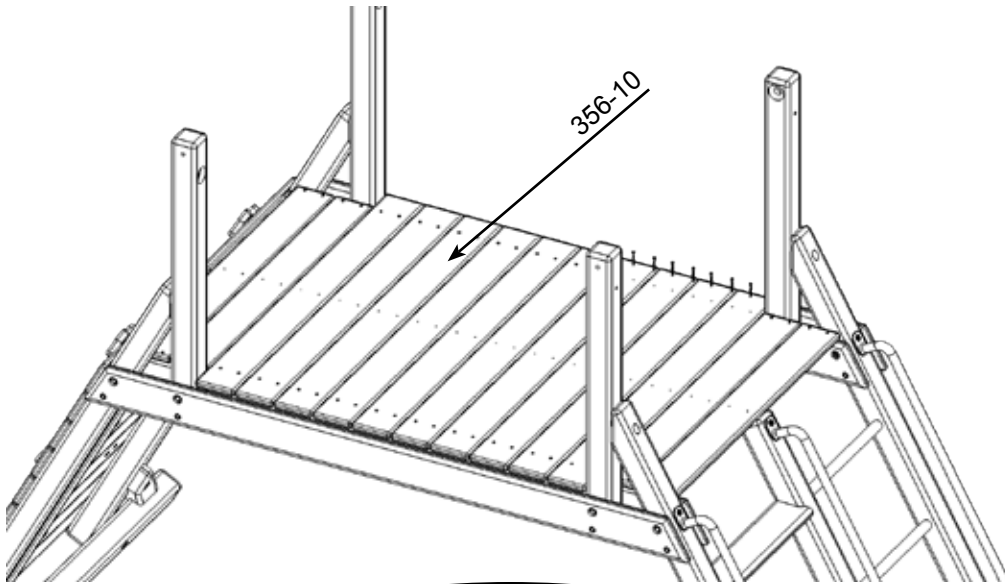

# Main Assembly

## PARTS NEEDED

356-33- 96" Top Joist-	(1)
356-34- 96" SB Top Joist-	(1)
356-30- 85 1/2" Rope Ladder Arm-	(1)
356-31- 85 1/2" Trapeze Arm-	(1)

## HARDWARE NEEDED

A-6- 3/8" x 6 1/2" Hex Bolt-	(4)	A-9- 3/8" Bolt Cup-	(4)
R- 3/8" USS Flatwasher-	(4)	P- 3/8" Split Lockwasher-	(4)
E- 3/8" Hex Nut-	(4)	A-1- 3/8" Acorn Nut Plated-	(4)

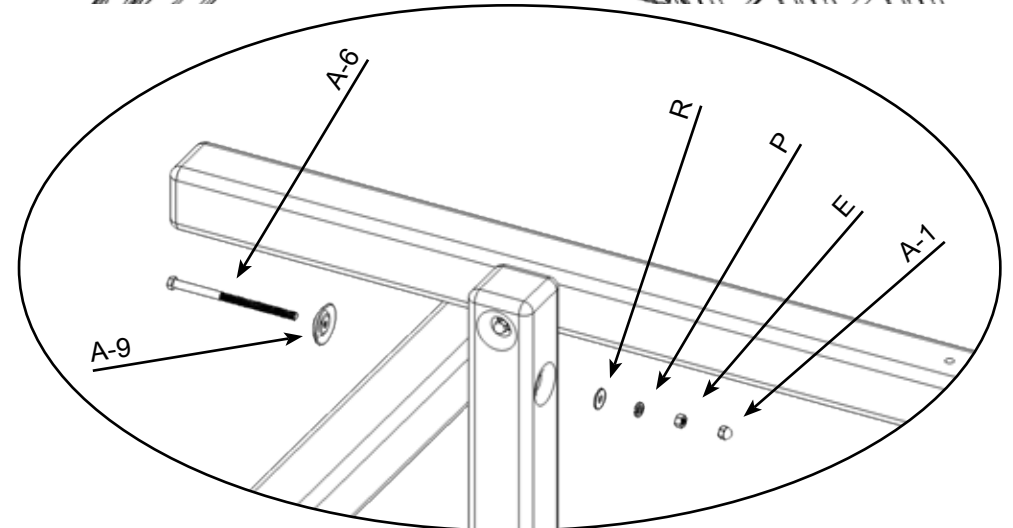
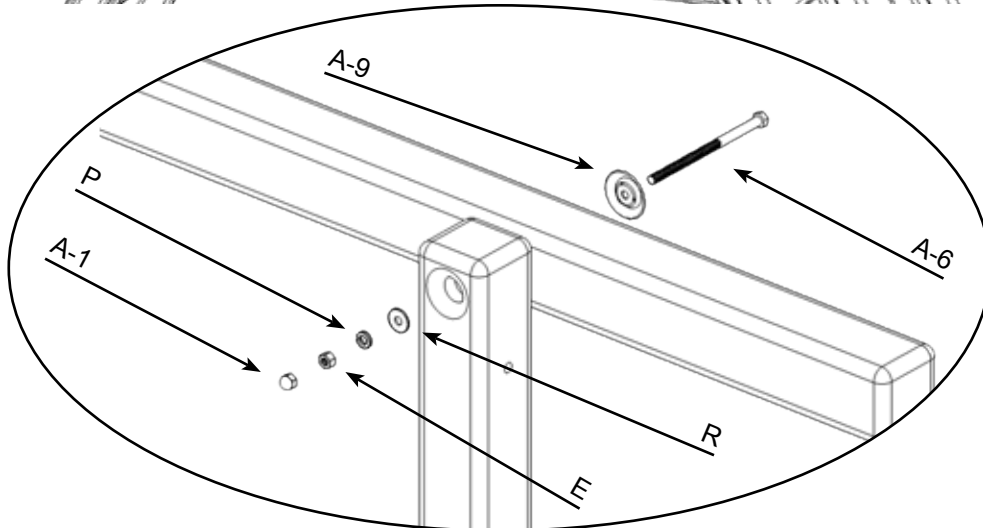
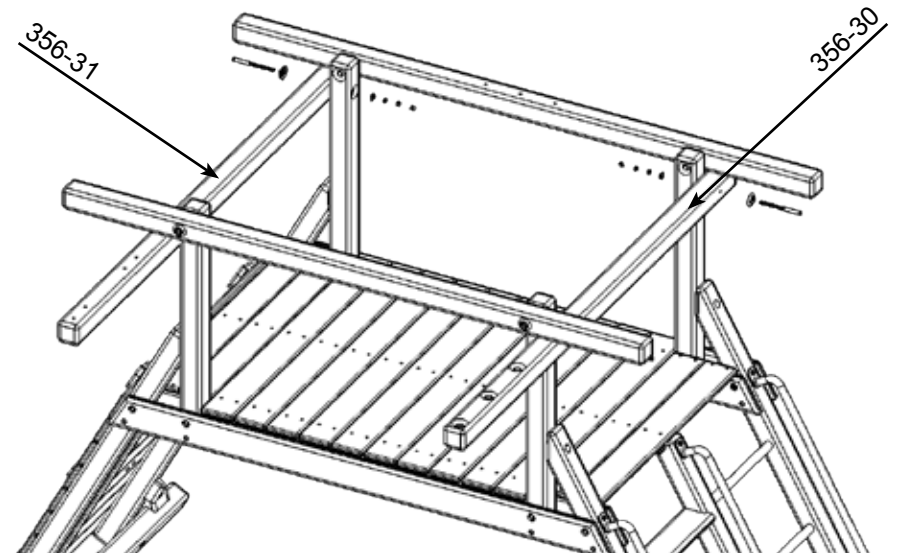
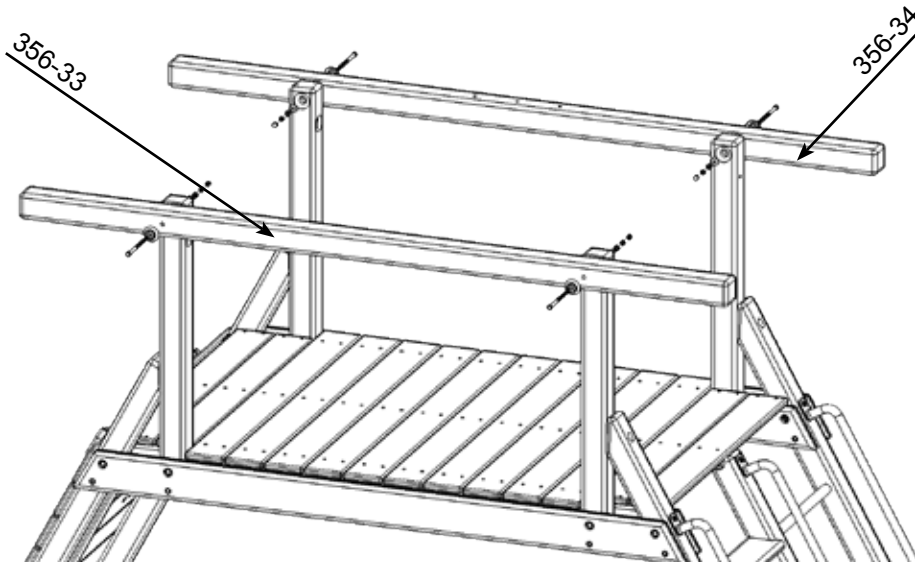

# Main Assembly

## PARTS NEEDED

356-7- 60 1/2" Long Bottom Rail Facia- (1)  
356-17- 75" Center Post- (1)

Q- 1/4" USS Flatwasher- (2)  
O- 3/8" T-Nut- (1)  
A-3- 3/8" x 1 1/2" Hex Bolt-

## HARDWARE NEEDED

(2) F- 1/4" x 3" Hex Lag Screw- (2)  
(1) R- 3/8" USS Flatwasher- (2)  
(1) H- 3/8" x 3 1/2" Hex Lag Screw- (1)

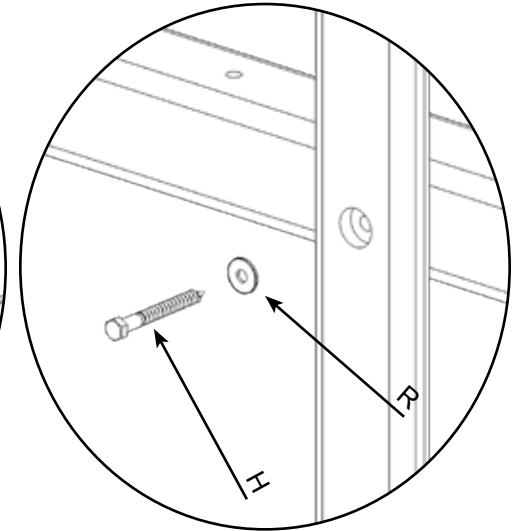
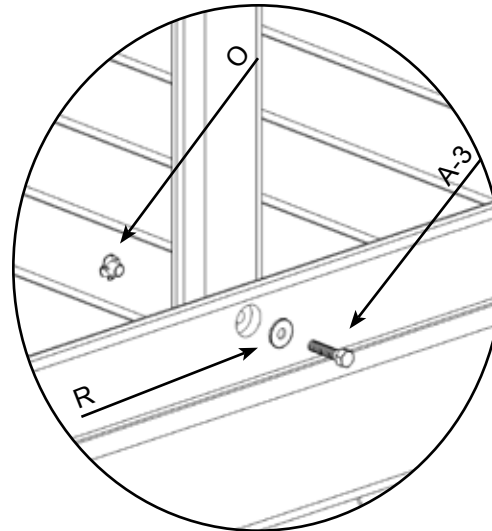
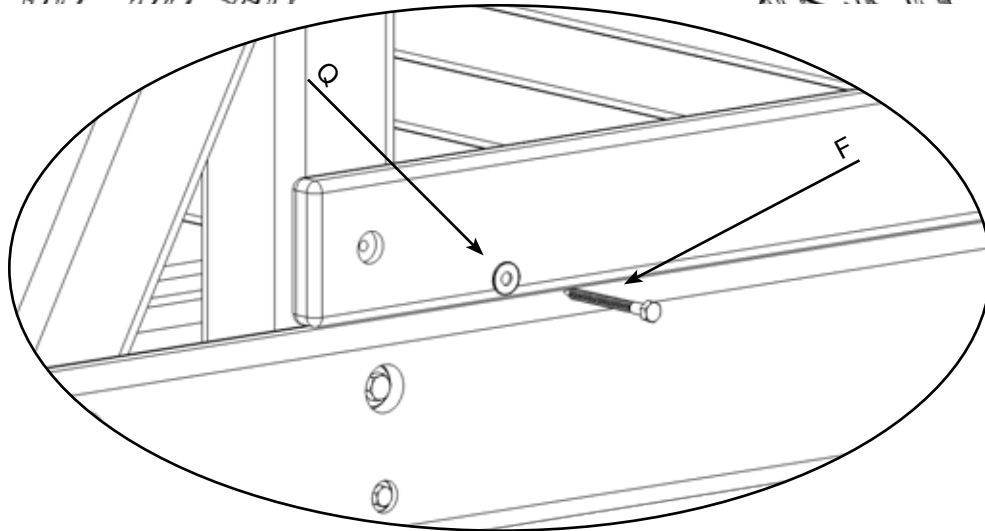
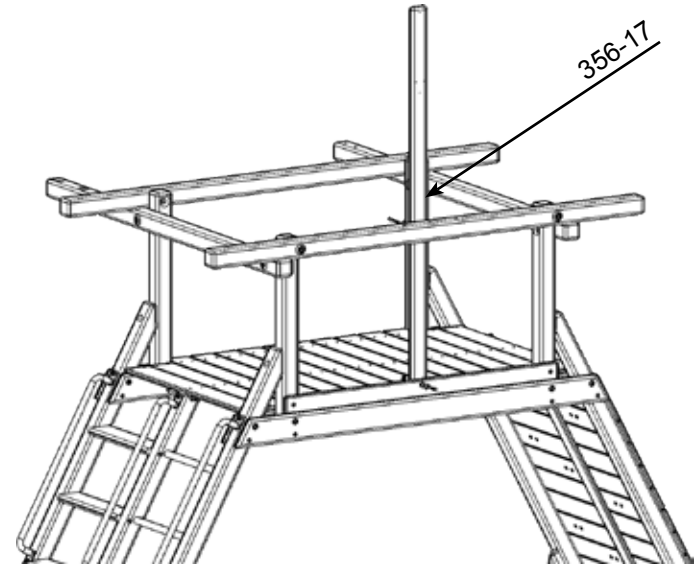
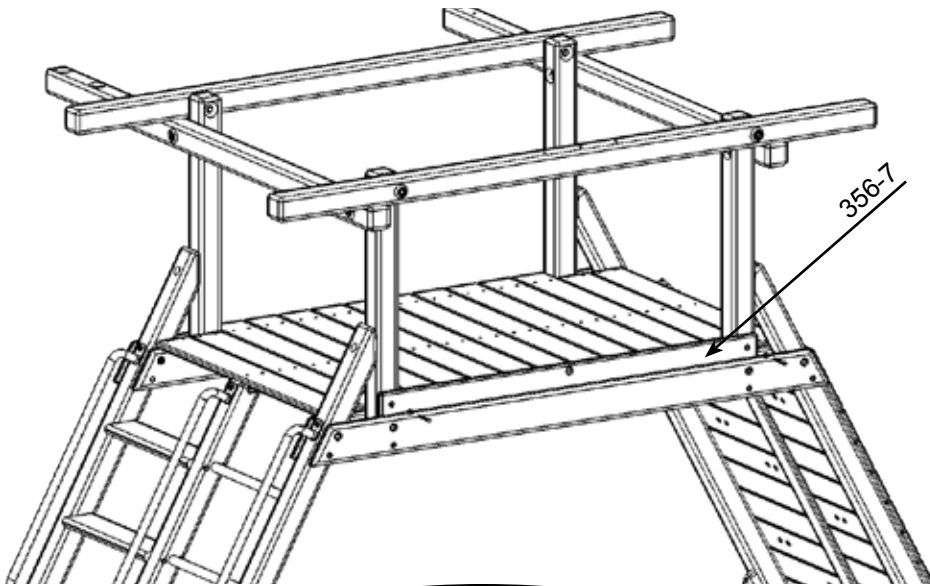

# Main Assembly

## PARTS NEEDED

356-2- 31 15/16" Rail Facia- (1)  
356-17- 75" Center Post- (1)

Q- 1/4" USS Flatwasher- (1)  
O- 3/8" T-Nut- (1)  
A-3- 3/8" x 1 1/2" Hex Bolt-

## HARDWARE NEEDED

(1) F- 1/4" x 3" Hex Lag Screw- (1)  
(1) R- 3/8" USS Flatwasher- (2)  
(1) H- 3/8" x 3 1/2" Hex Lag Screw- (1)

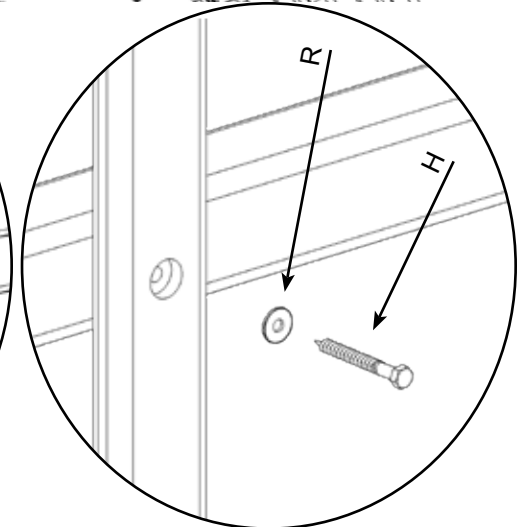
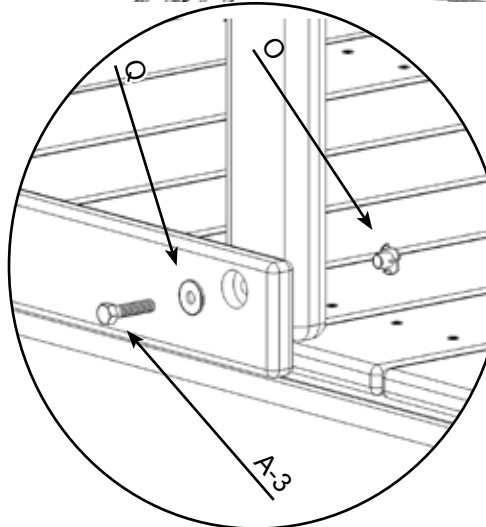
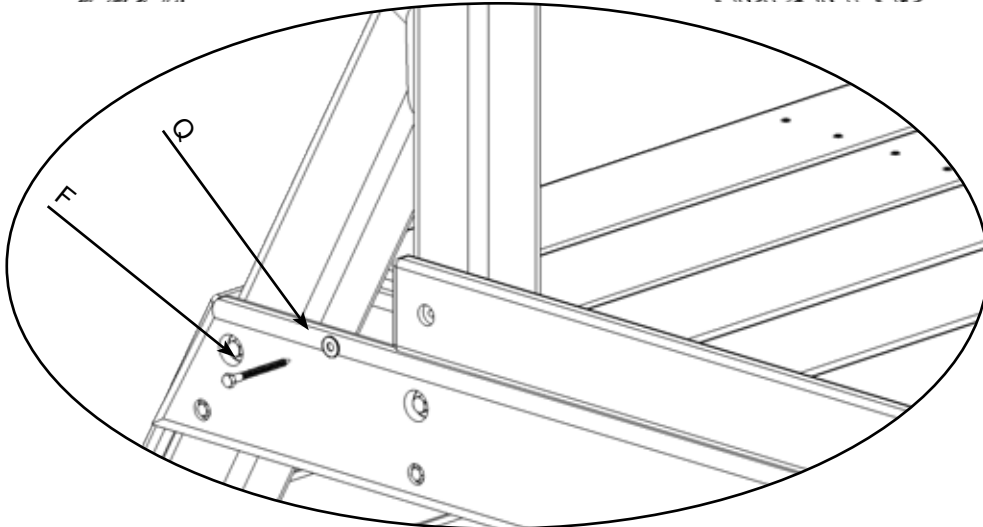
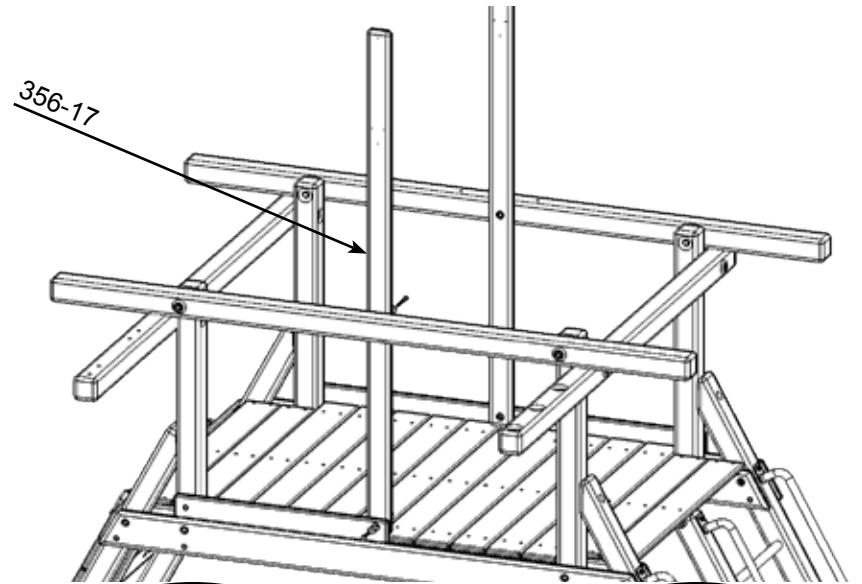
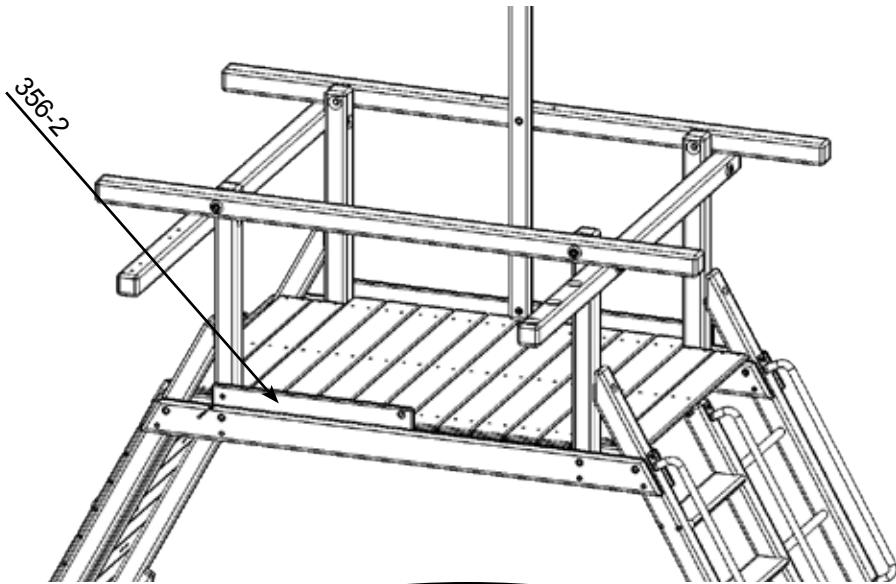

# Main Assembly

## PARTS NEEDED

356-C- Swing Beam Tri-Plate- (1)  
 A-Frame Assembly- (1)

SB-3- 1/2" x 3" Carriage Bolt- (2)  
 SB-18- 1/2" USS Flatwasher- (4)  
 SB-7- 1/2" Hex Nut- (4)  
 SB-5- 1/2" x 9" Carriage Bolt- (1)

## HARDWARE NEEDED

(2) SB-19- 3/4" USS Flatwasher- (4)  
 (4) SB-16- 1/2" Split Lockwasher- (4)  
 (4) SB-2- 1/2" Acorn Nut Plated- (4)  
 (1) SB-4- 1/2" x 6 1/2" Carriage Bolt- (1)

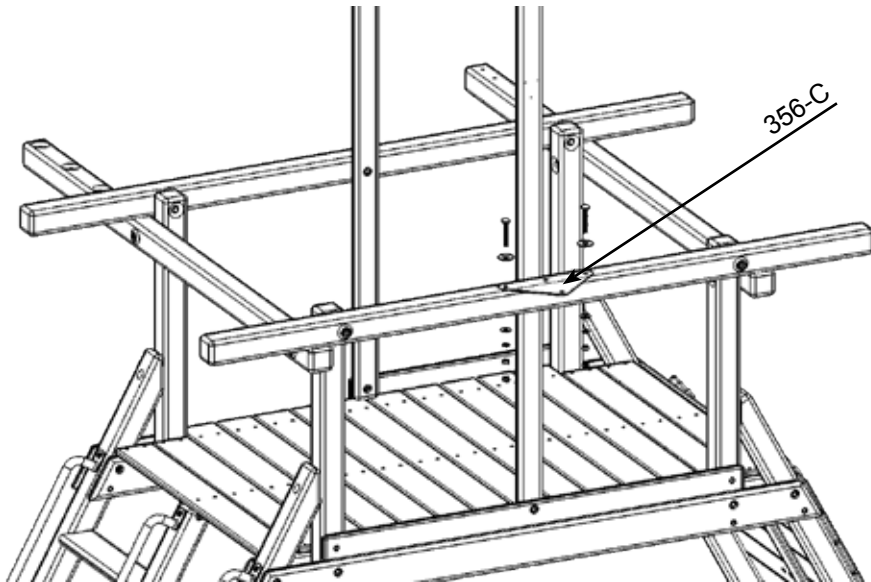

PLACE A-FRAME ON THE SB TOP JOIST AND SQUEEZE THE LEGS TOGETHER UNTIL LEVEL

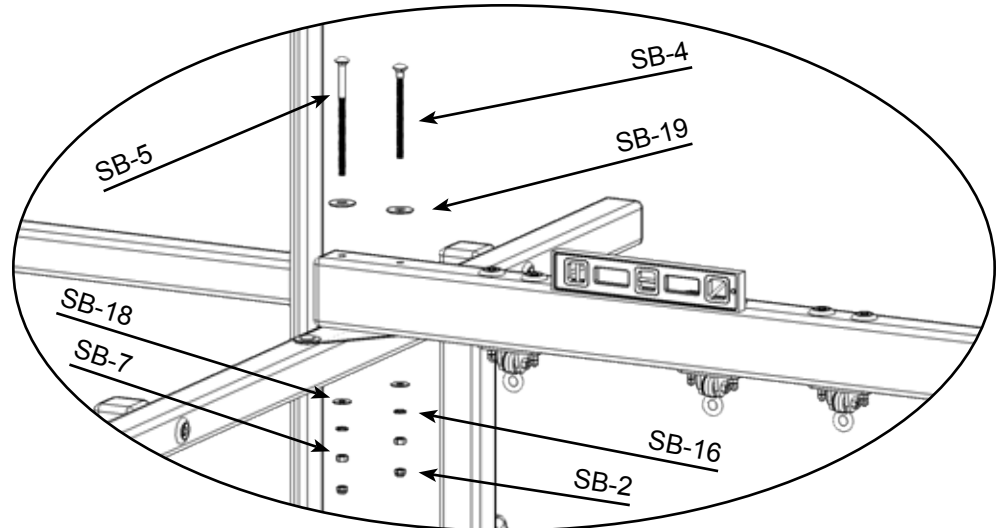
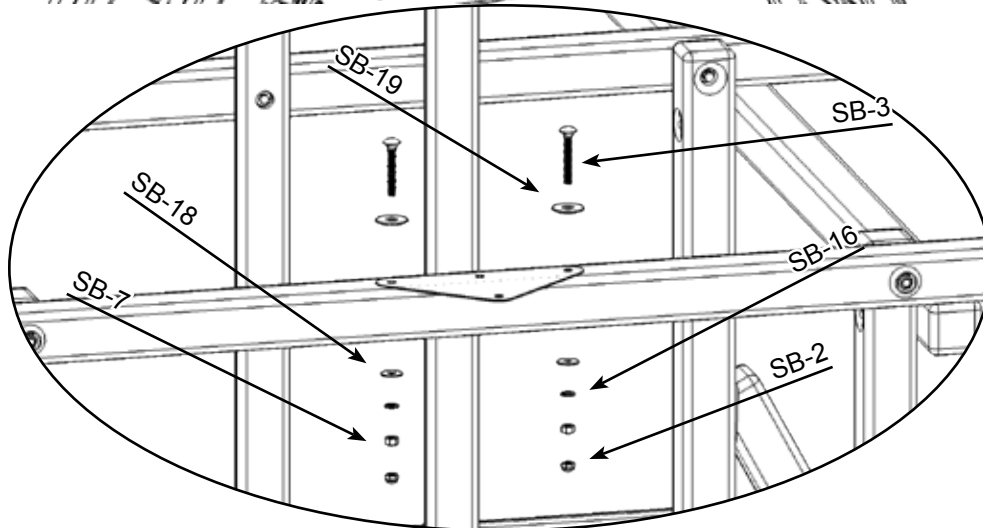
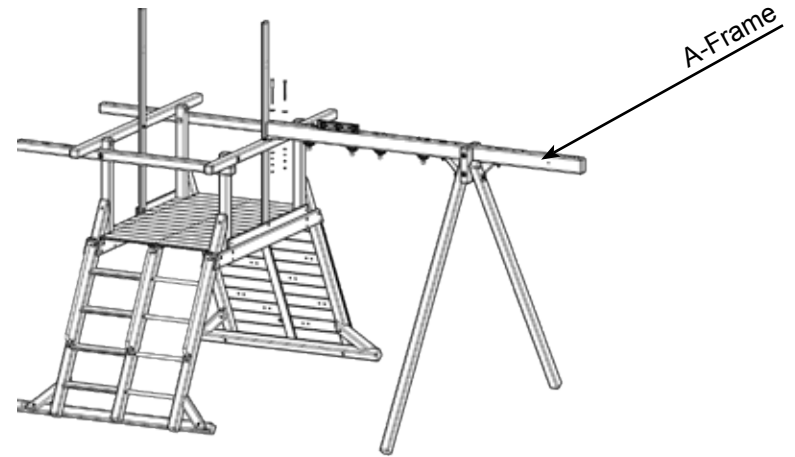

# Main Assembly

## PARTS NEEDED

356-38- 72" A-Frame Crossmember- (1)

SB-17- 3/8" USS Flatwasher-  
 SB-4- 1/2" x 7" Carriage Bolt-  
 SB-18- 1/2" USS Flatwasher-  
 SB-7- 1/2" Hex Nut-

## HARDWARE NEEDED

(2) SB-12- 3/8" x 5" Hex Lag Screw- (2)  
 (2) SB-19- 3/4" USS Flatwasher- (2)  
 (2) SB-16- 1/2 Split Lockwasher- (2)  
 (2) SB-2- 1/2" Acorn Nut Plated- (2)

AFTER ATTACHING AND LEVELING THE A-FRAME LOCK IN PLACE AS SHOWN

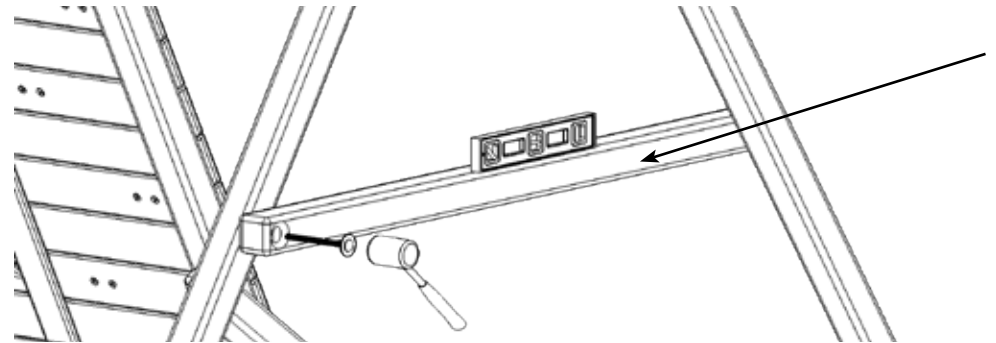
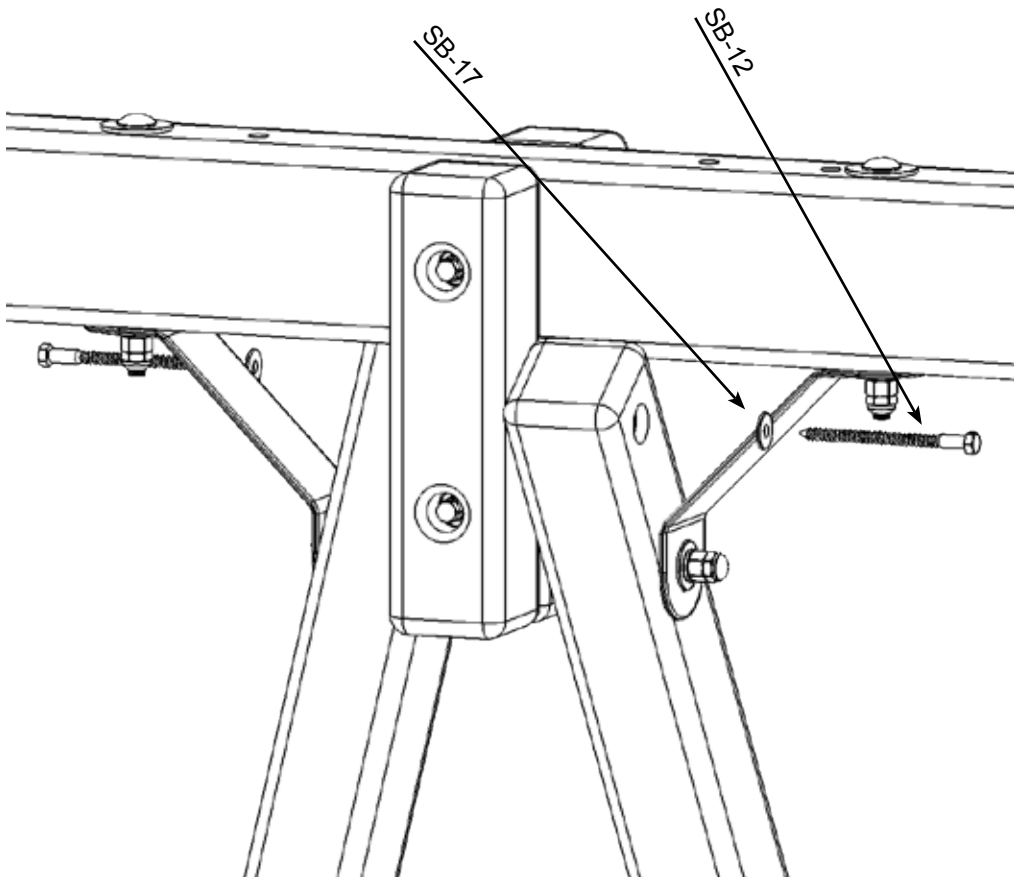

LEVEL CROSSMEMBER ACROSS THE A-FRAME LEGS AND MARK HOLES

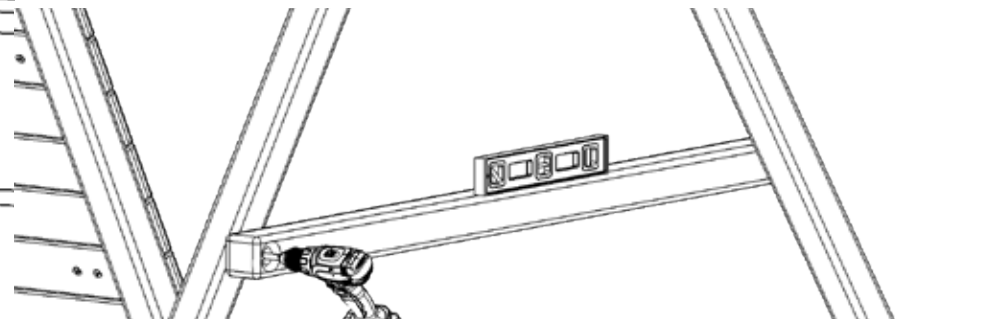

UNING A 9/16" DRILL BIT DRILL OUT HOLES AND ASSEMBLE AS SHOWN

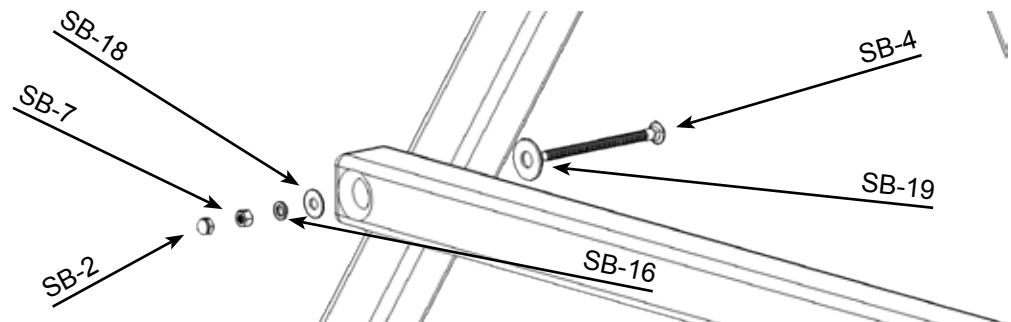

# Main Assembly

## PARTS NEEDED

- 356-Q- 66" Chained Belt Swing- (2)
- 356-H- 14' Yellow Rope- (1)
- 356-L- Disc Swing- (1)

## HARDWARE NEEDED

- SB-21- 8 x 80mm Spring Clip- (4)

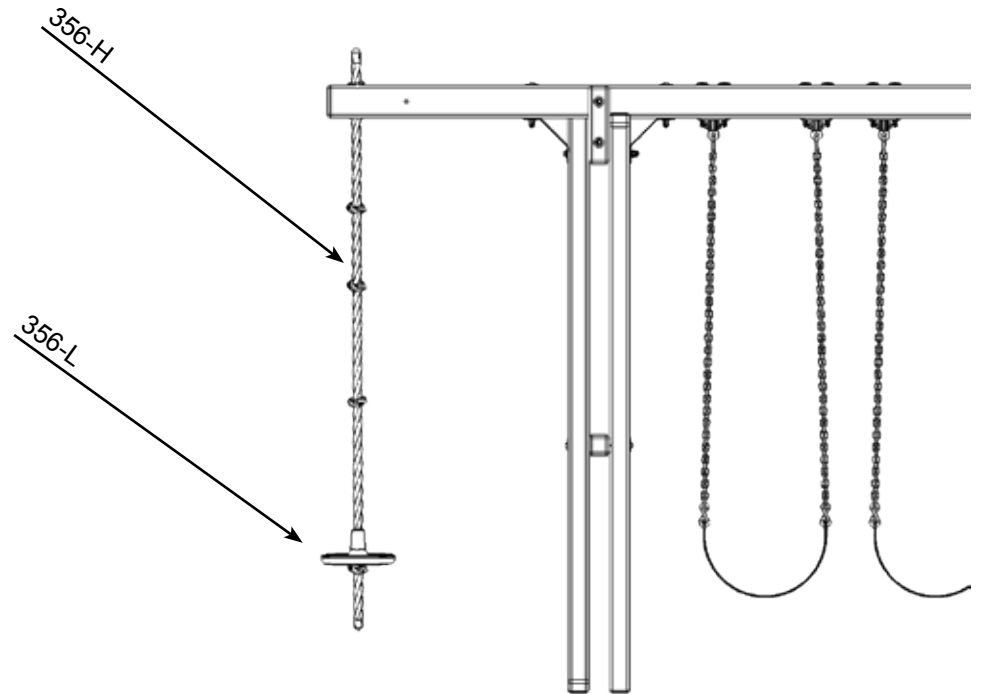
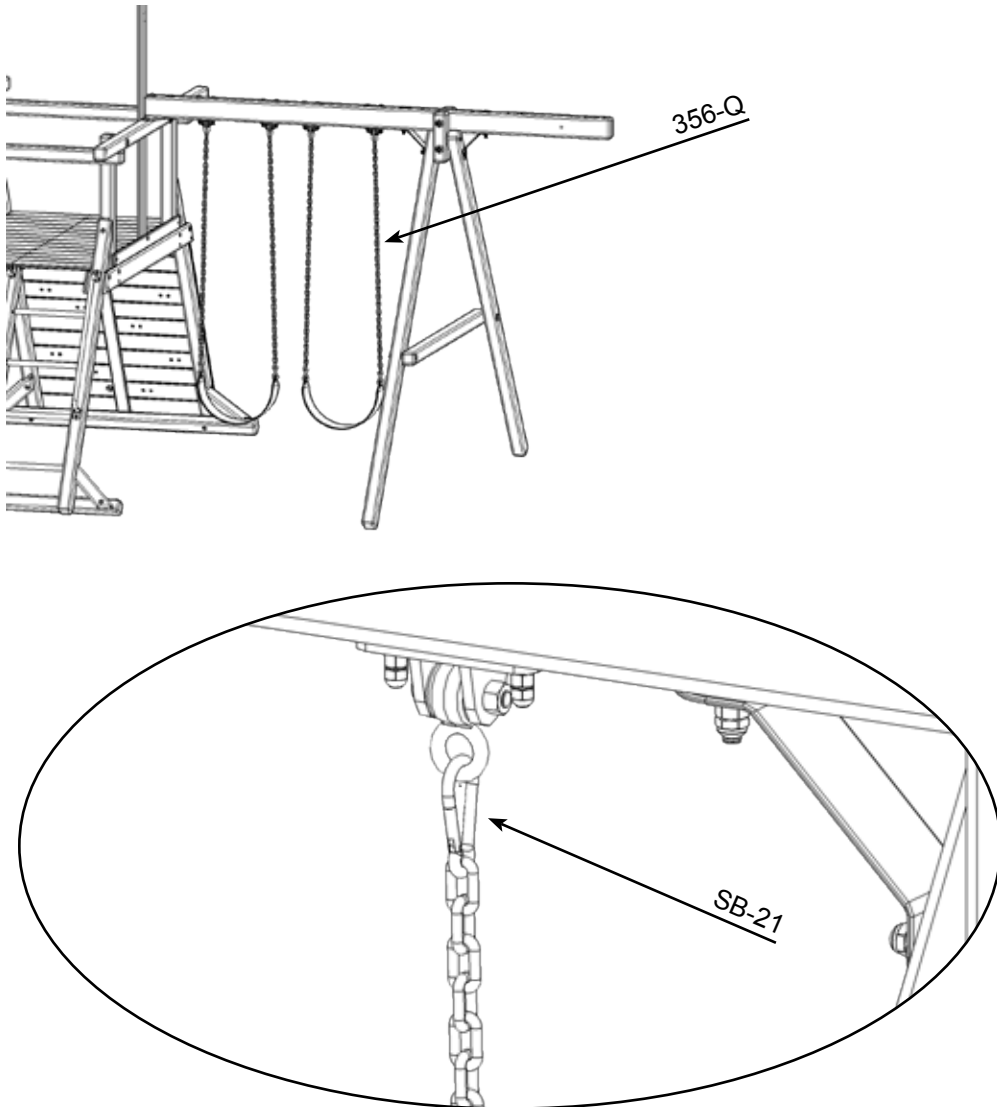

SLIP THE ROPE THROUGH THE SWINGBEAM AND TIE A KNOT. THEN TIE A KNOT EVERY 2 TO 3 FEET. PLACE THE 356-L DISC SWING ON THE ROPE AND TIE A DOUBLE KNOT SECURING IT TO THE ROPE.

# Main Assembly

## PARTS NEEDED

356-I- 17' Yellow Rope w/ Caps-	(3)
356-16- 22" Rope Ladder Rung-	(6)
356-N- Ductile Iron Swing Hanger-	(2)

## HARDWARE NEEDED

A-4- 3/8" x 5" Hex Bolt-	(4)	A-9- 3/8" Bolt Cup-	(4)
R- 3/8" USS Flatwasher-	(4)	P- 3/8" Split Lockwasher-	(4)
A-7- 3/8" Nylon Insert Locknut-	(4)	A-1- 3/8" Acorn Nut Plated-	(4)

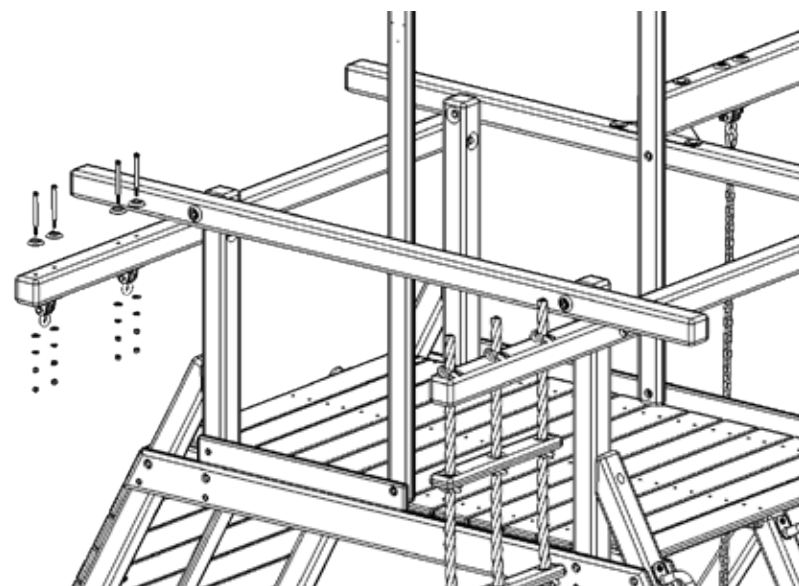
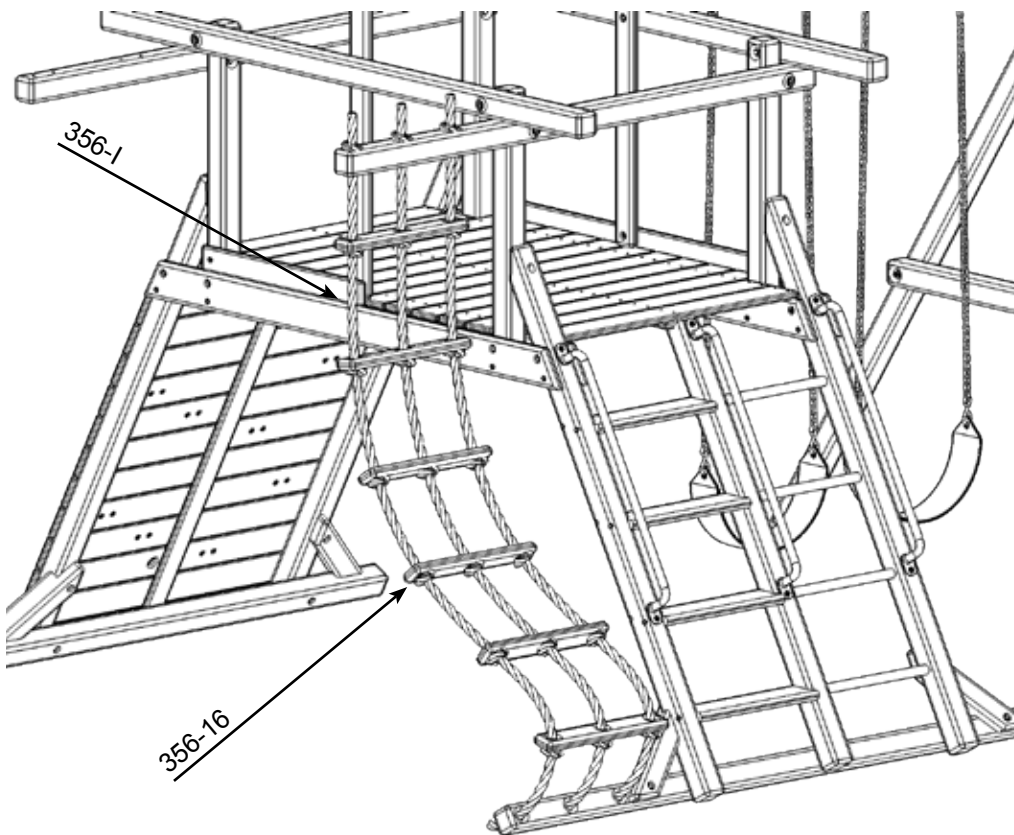

SLIDE ONE END OF ROPE THROUGH THE UPPER ROPE ARM AND TIE A GOOD KNOT. THEN TAKE A 356-16 AND SLIDE IT UP ABOUT A 1 TO 1 1/2 FT BELOW THE ROPE ARM AND TIE KNOT HOLDING IT. REPEAT FOR ALL 356-16'S AND TIE A KNOT ON THE ROPE RUNNER.

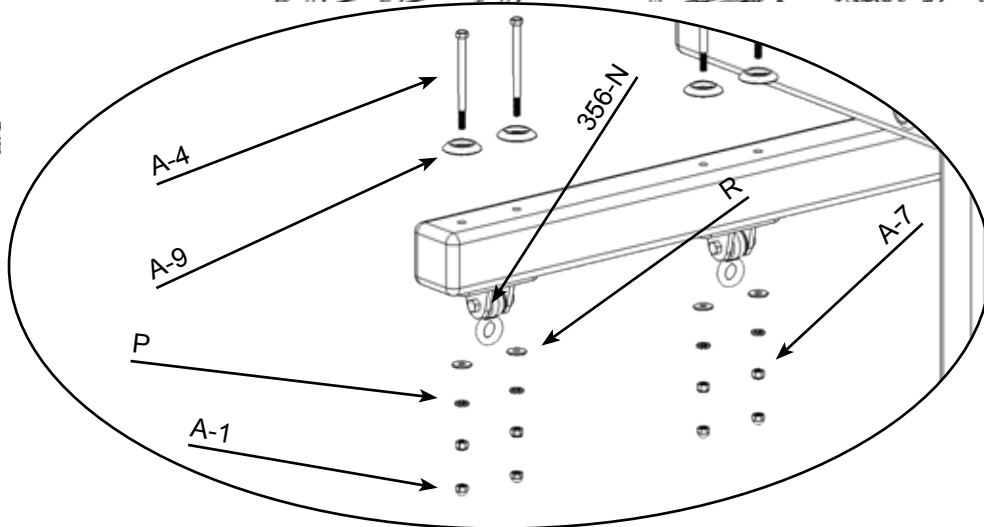



# Main Assembly

## PARTS NEEDED

- 356-J- 16" Trapeze Bar w/ Rings- (1)
- 356-F- Playgrip Safety Handles- (4)

## HARDWARE NEEDED

- A-10- 8 x 80mm Spring Clip- (2)
- K- #14 x 2" Pan Phillips T/S- (8)
- Q- 1/4" USS Flatwasher- (8)

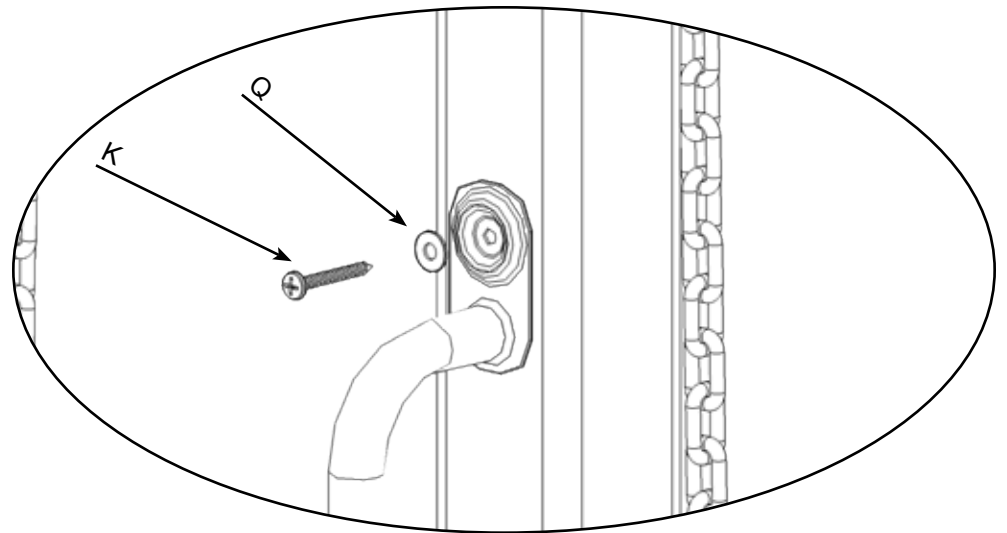
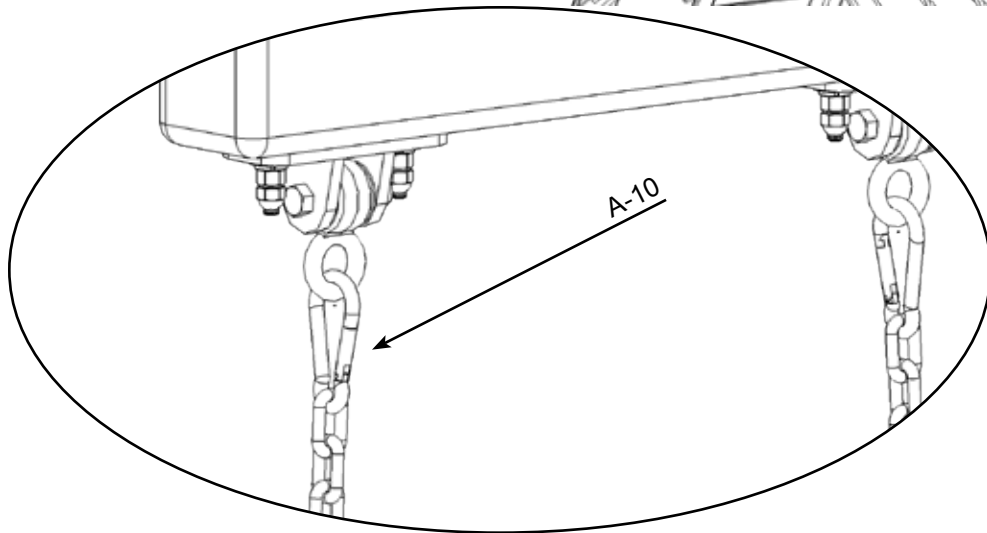
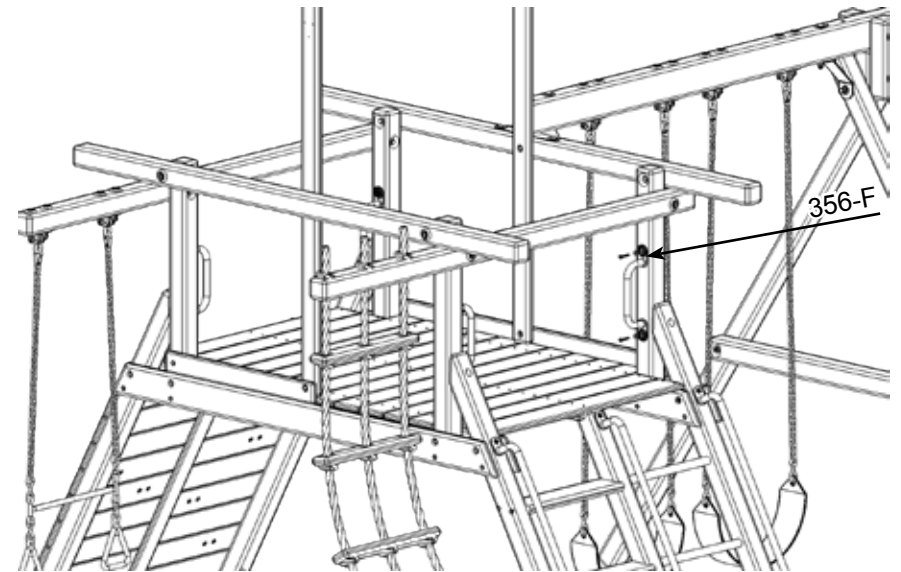
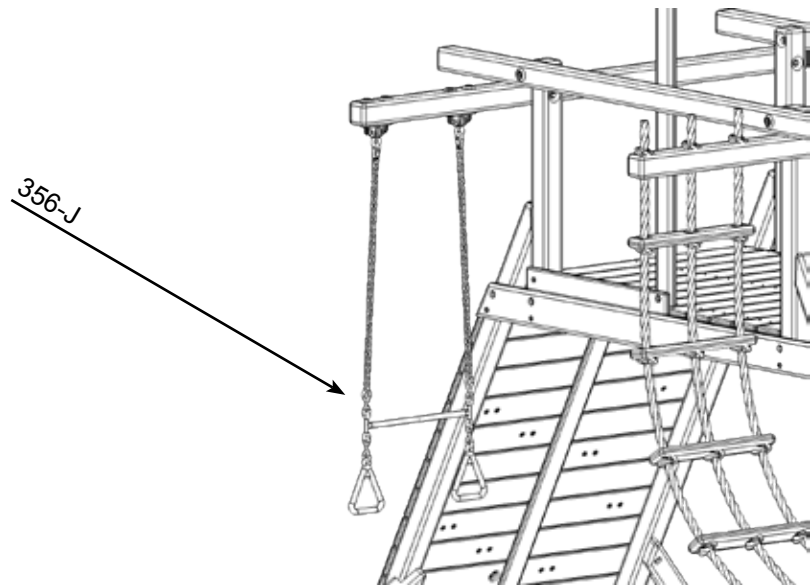

# Main Assembly

## PARTS NEEDED

356-A- 90 Degree Bracket- (2)  
Slide- (1)

## HARDWARE NEEDED

Q- 1/4" USS Flatwasher- (7)  
J- #14 x 1" Pan Phillips T/S- (4)  
L- 1/4" x 1 1/4" Pan Phillips M/S- (3)  
N- 1/4" T-Nut- (3)

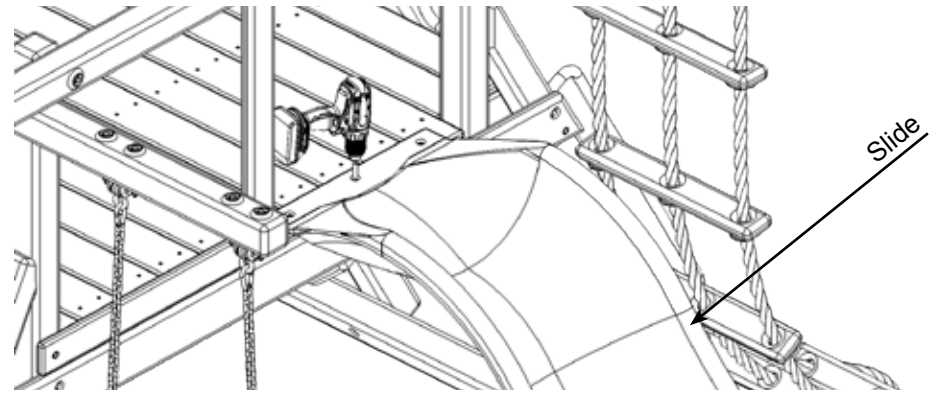
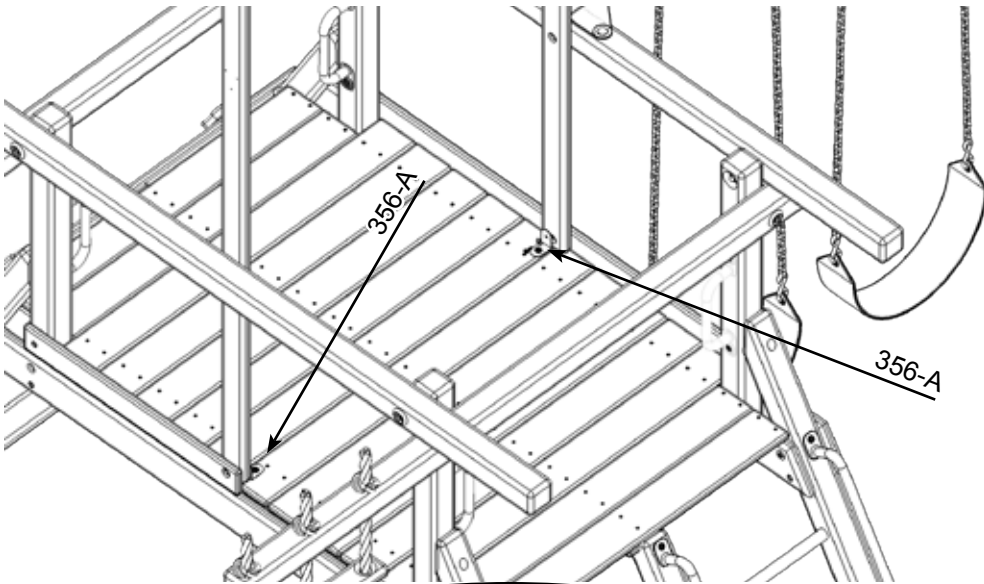

PLACE THE SLIDE ON THE DECK AND MARK HOLES TO BE DRILLED. THEN USING A 5/16" DRILL BIT, DRILL OUT THE MARKED LOCATIONS FOR THE HOLES. PLACE THE SLIDE BACK ON AND MOUNT AS SHOWN

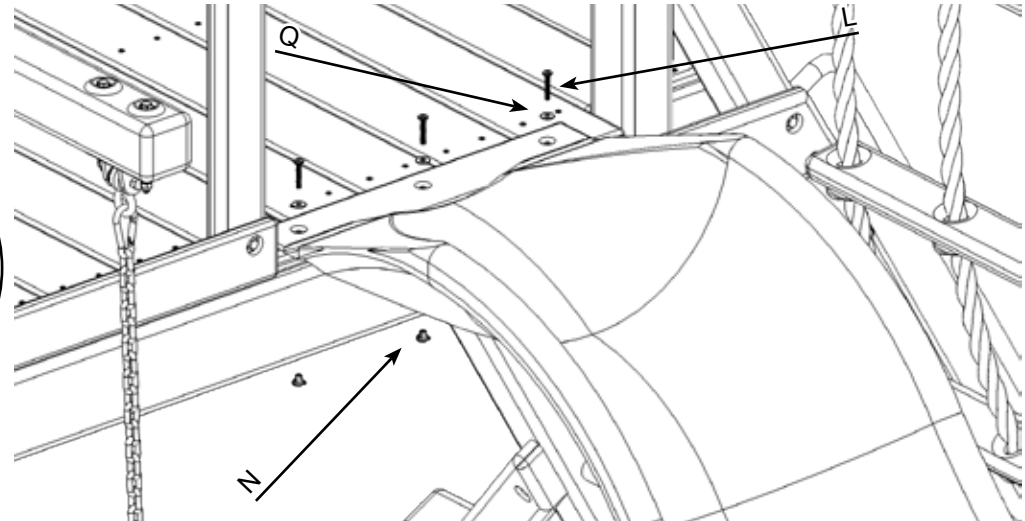
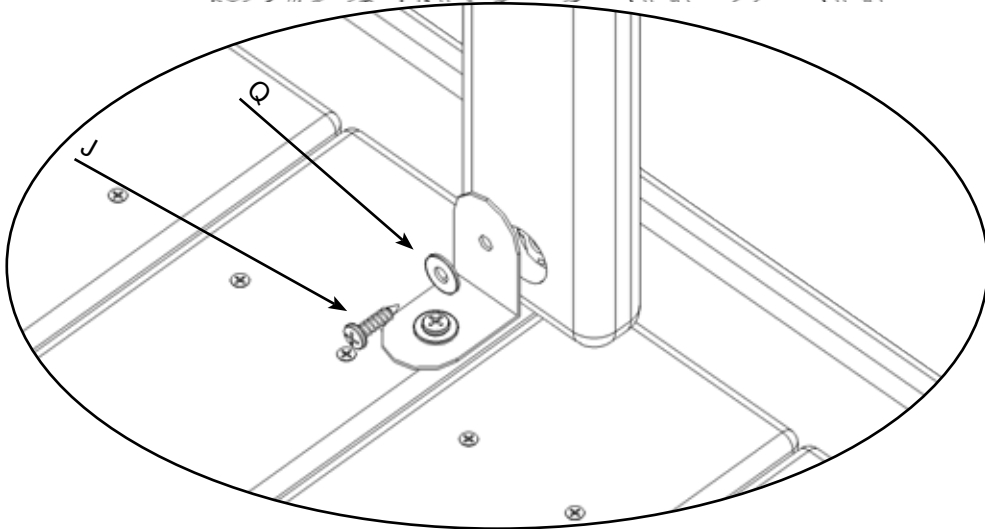

# Main Assembly

## PARTS NEEDED

356-S- 12" Ships' Wheel- (1)  
356-T- Telescope- (1)

## HARDWARE NEEDED

(Hardware with Accessories)

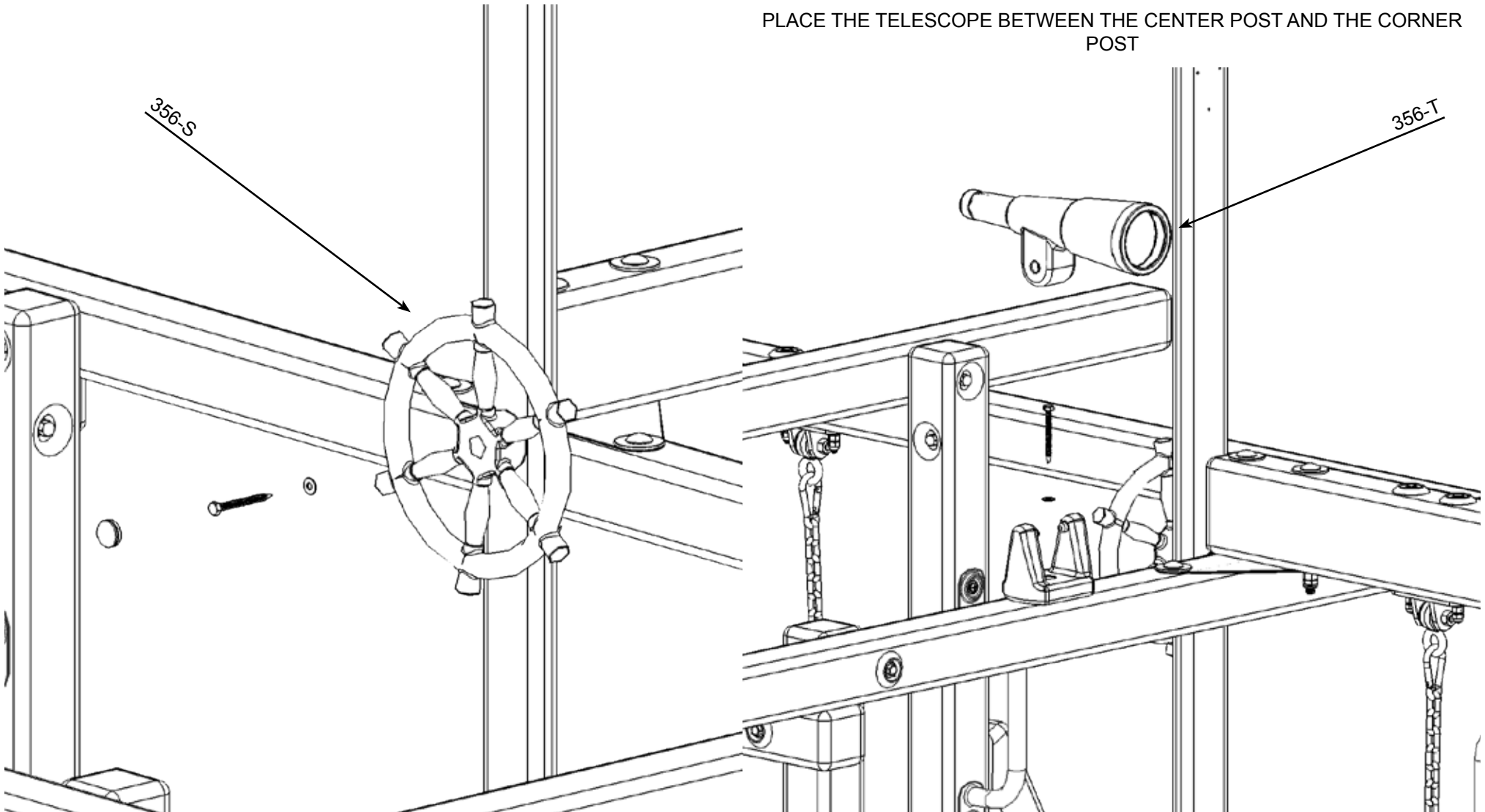

# Main Assembly

## PARTS NEEDED

356-P- Bull Ring Tire Swivel- (1)  
Tire Assembly- (1)

A-2- 3/8" x 3" Carriage Bolt- (2)  
R- 3/8" USS Flatwasher- (2)  
E- 3/8" Hex Nut- (2)  
A-10- 8 x 80mm Spring Clip- (3)

## HARDWARE NEEDED

A-8- 1/2" USS Flatwasher- (2)  
P- 3/8" Split Lockwasher- (2)  
A-1- 3/8" Acorn Nut Plated- (2)

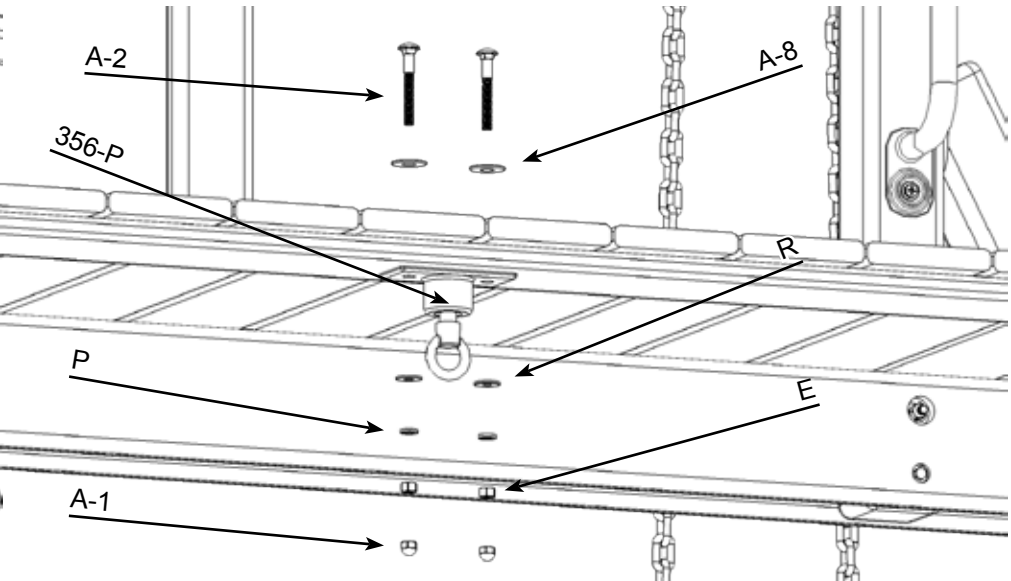
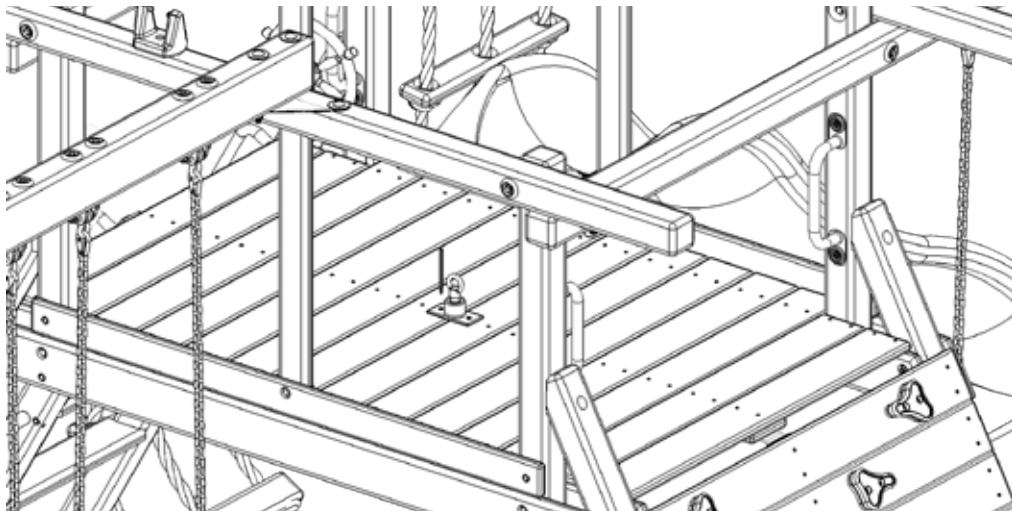

FIND THE CENTER OF THE DECK AND MARK THE HOLES TO BE DRILLED

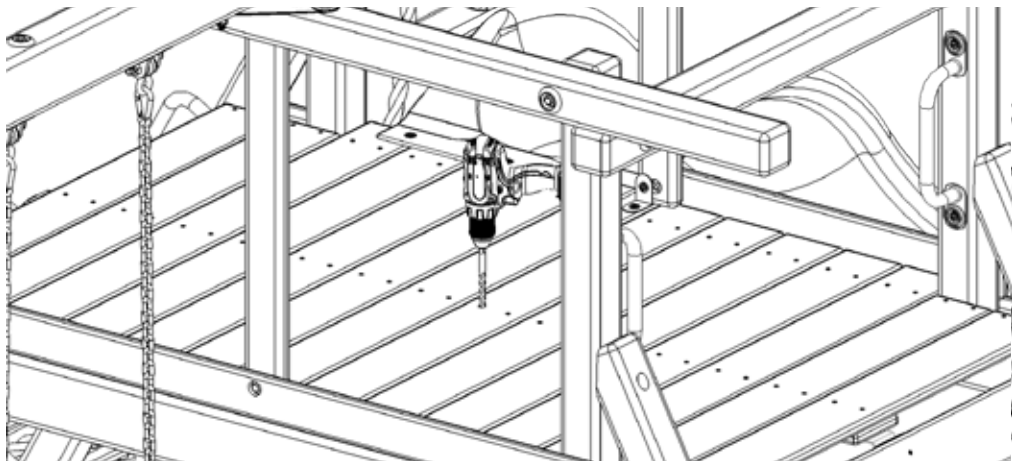

USING A 9/16" BIT DRILL THROUGH THE DECK ON THE MARKED HOLES

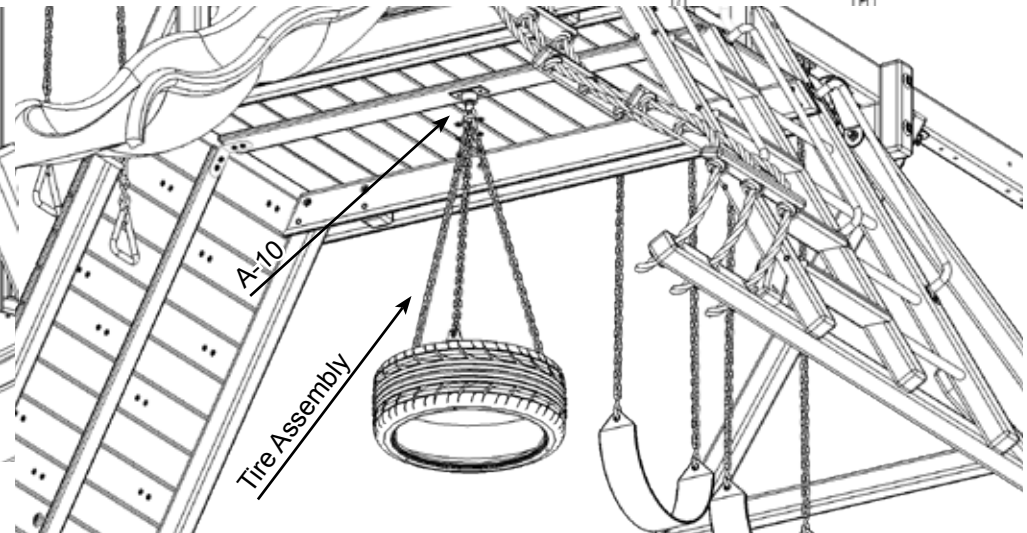

# Main Assembly

## PARTS NEEDED

356-20- 11" Rope Block-  
356-H- 14' Yellow Rope-

(1)  
(1)

## HARDWARE NEEDED

R- 3/8" USS Flatwasher-  
I- 3/8" x 5" Hex Lag Screw-

(2)  
(2)

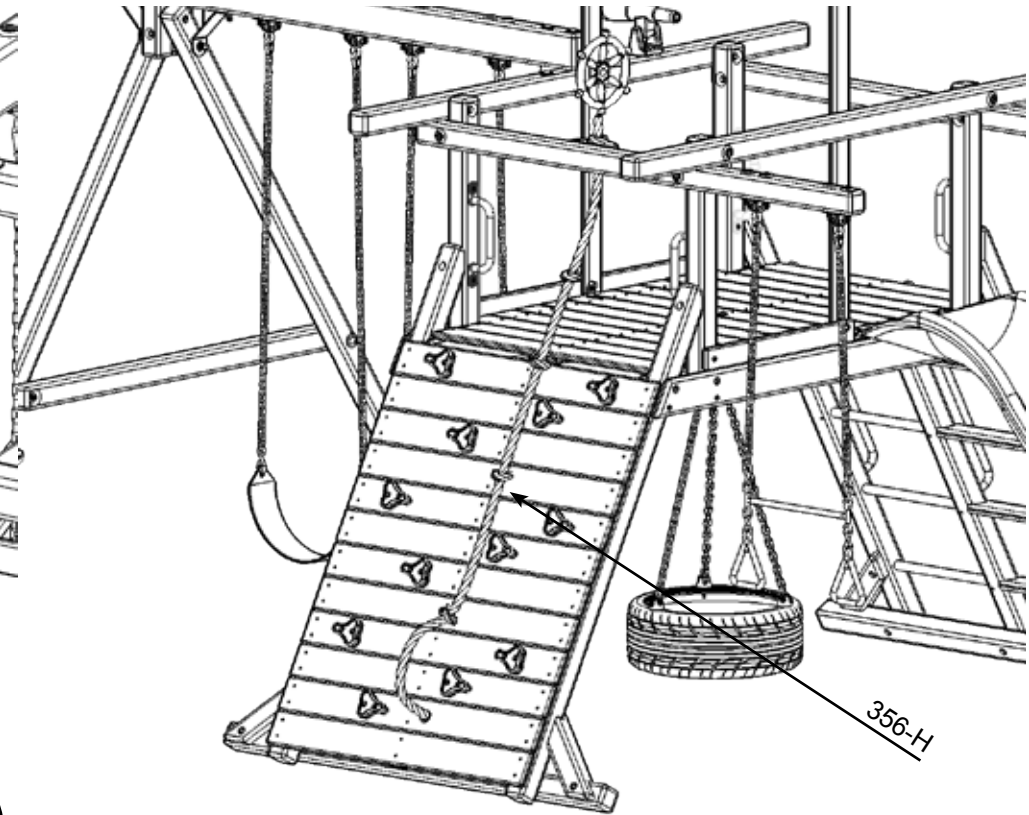
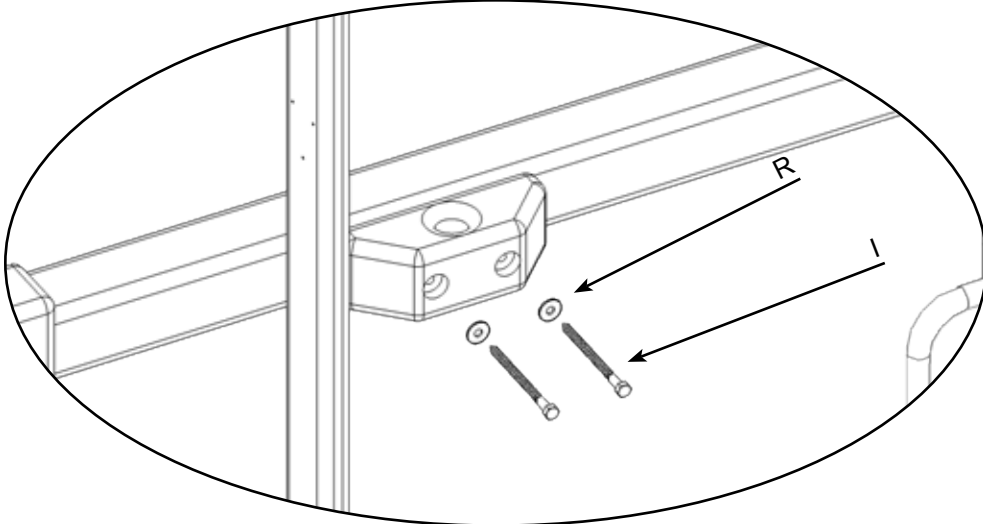
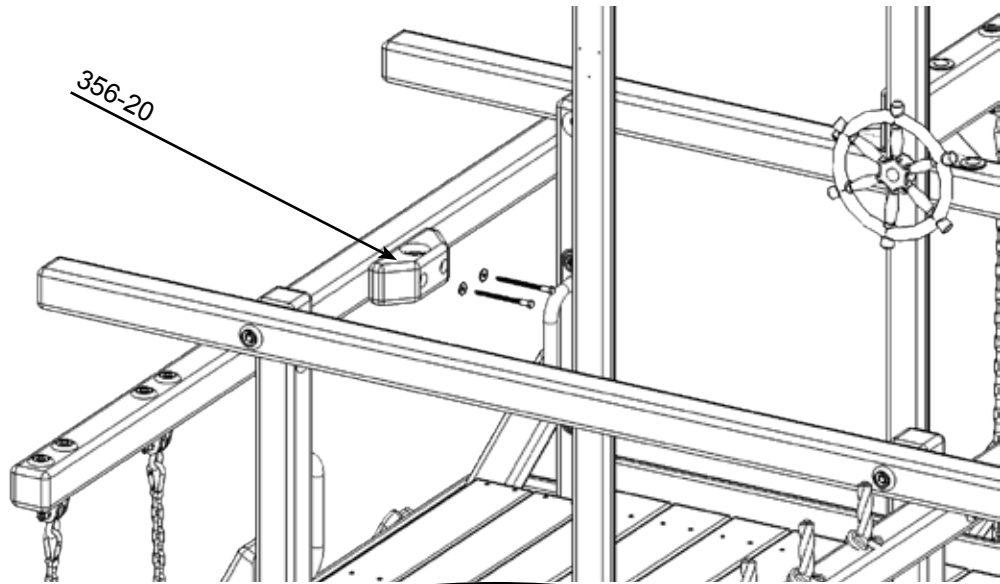

SLIP THE 356-H THROUGH THE ROPE BLOCK AND TIE A KNOT SECURING IT.  
TIE A COUPLE KNOTS AS YOU WORK YOUR WAY DOWN THE  
ROCKWALL. SLIP THE 356-H THROUGH THE ROCKWALL BOARD W/ ROPE  
HOLE AND TIE A KNOT OR 2 SECURING IT.

# Main Assembly

## PARTS NEEDED

- 356-21- 19" (L) Gusset- (1)
- 356-22- 19" (R) Gusset- (1)
- 356-U- Spiral Ground Anchors- (4)

## HARDWARE NEEDED

- R- 3/8" USS Flatwasher- (8)
- H- 3/8" x 3 1/2" Hex Lag Screw- (8)

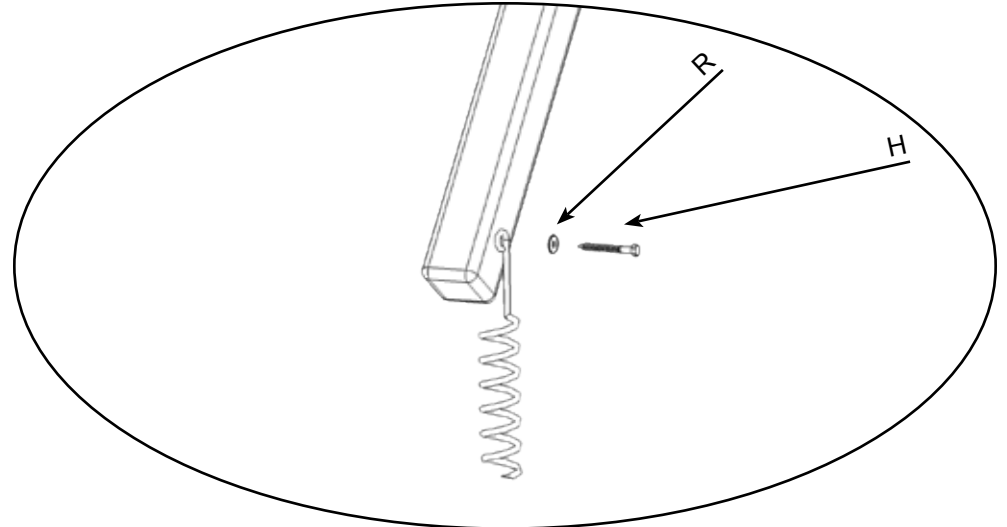
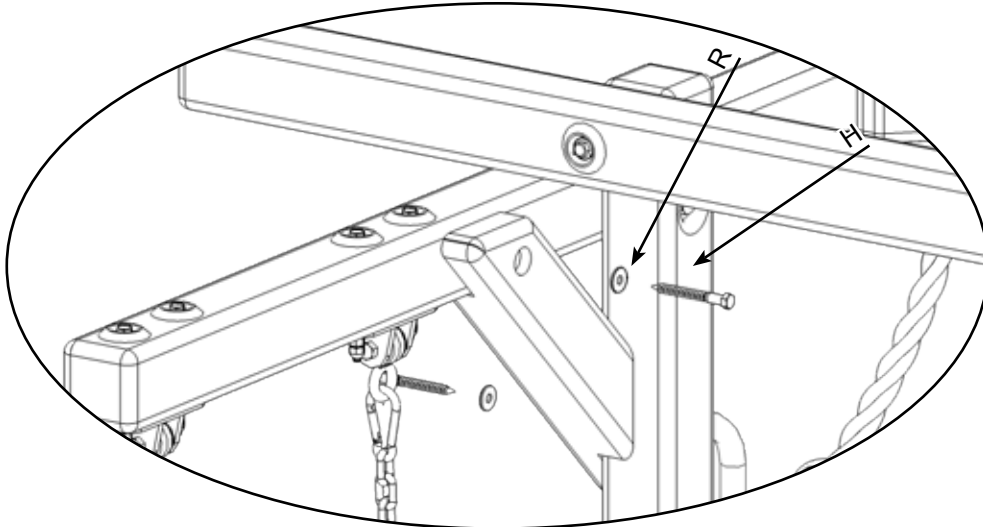
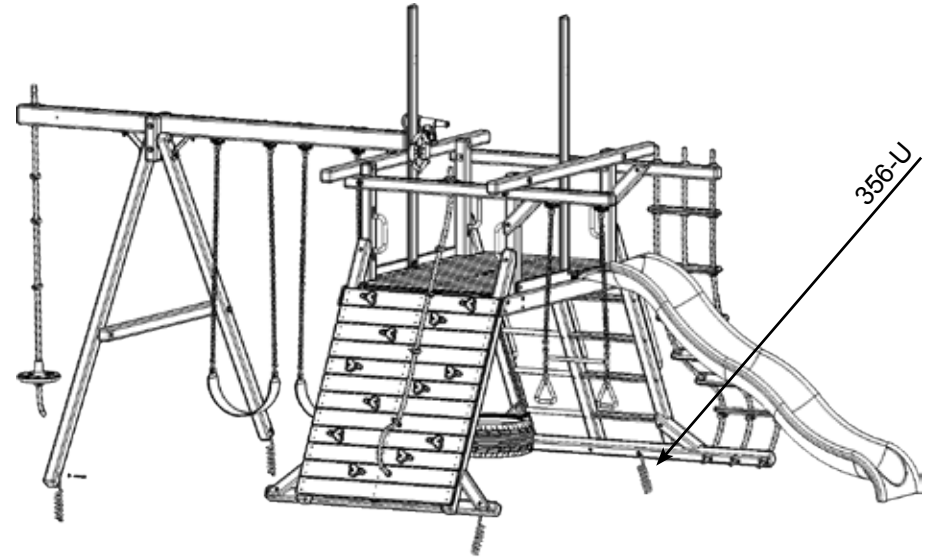
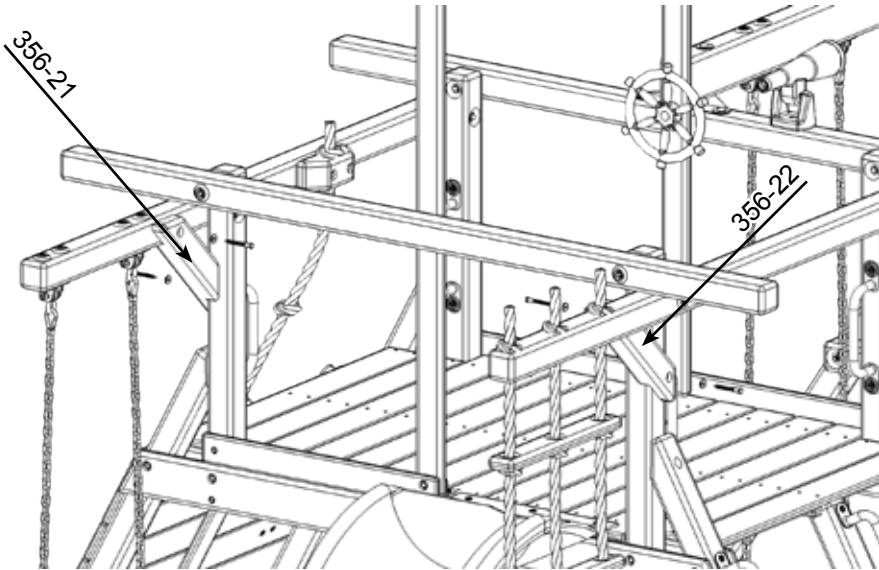

# Tarp Install

## PARTS NEEDED

- 357-5- 50" Center Tarp Board- (1)
- 357-6- 56 3/4" End Tarp Board- (2)

## HARDWARE NEEDED

- G- 1/4" x 4 1/2" Hex Lag Screw- (4)
- Q- 1/4" USS Flatwasher- (4)
- B- 2 1/2" Coated Deck Screw- (4)

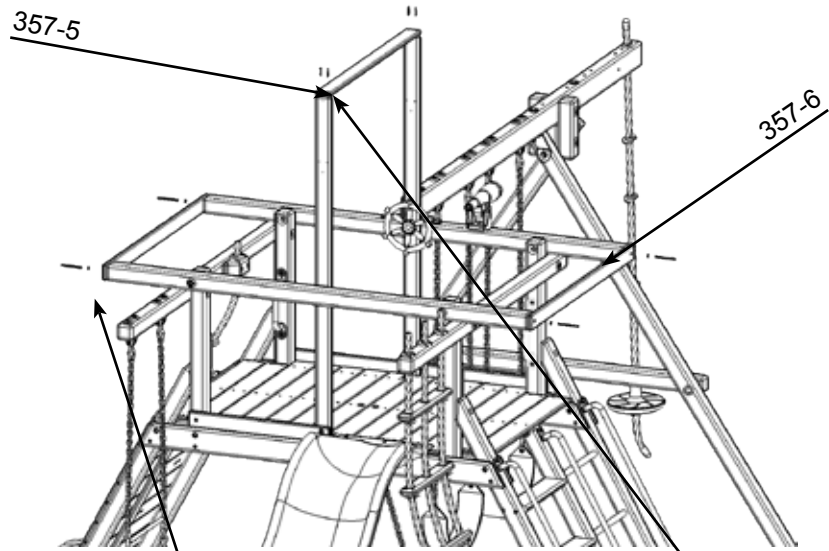

PLACE TARP OVER THE UNIT AND MARK THE LOCATION OF THE TARP SNAPS

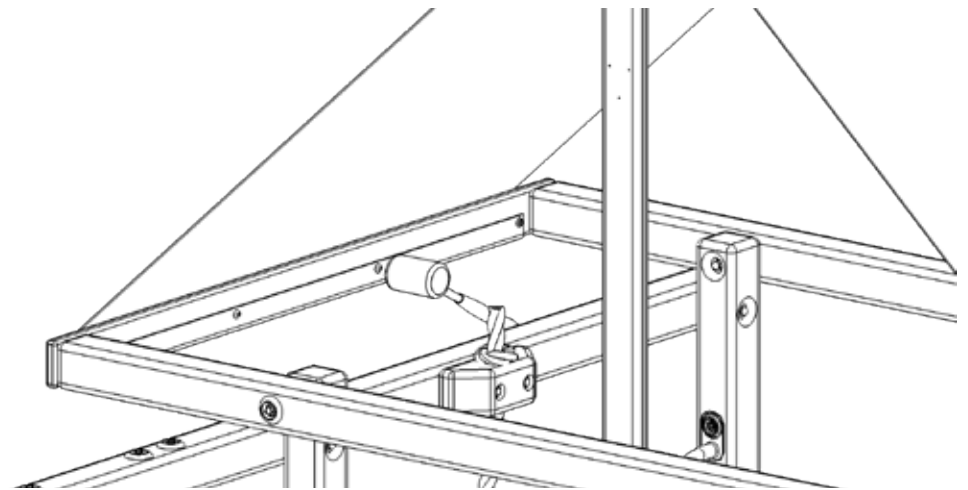

SCREW THE 5/8" PHILLIPS SCREW SNAPS IN AT THE MARKED LOCATIONS

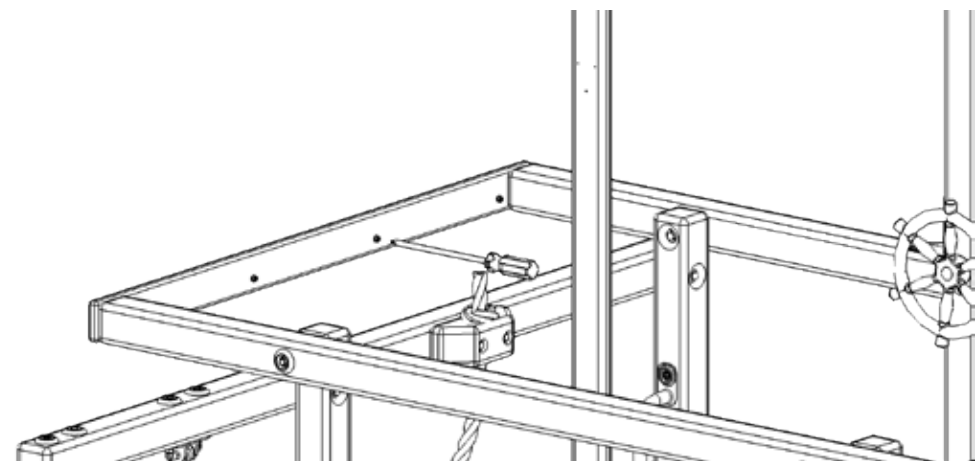
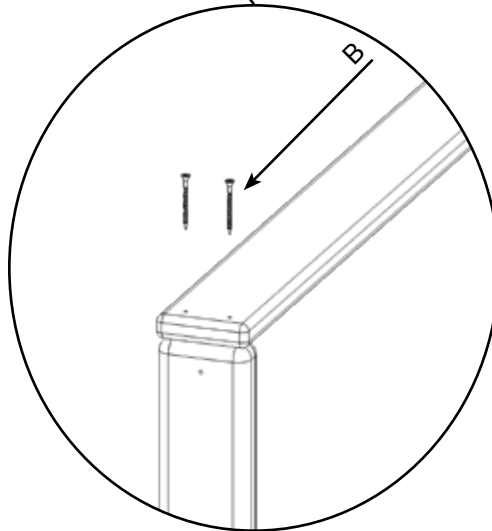
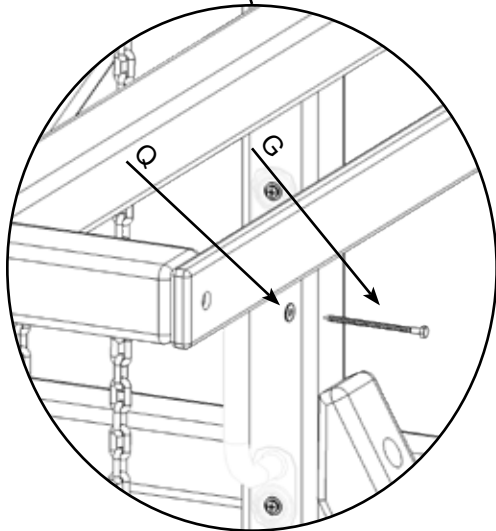

# Finished Tarp Assembly

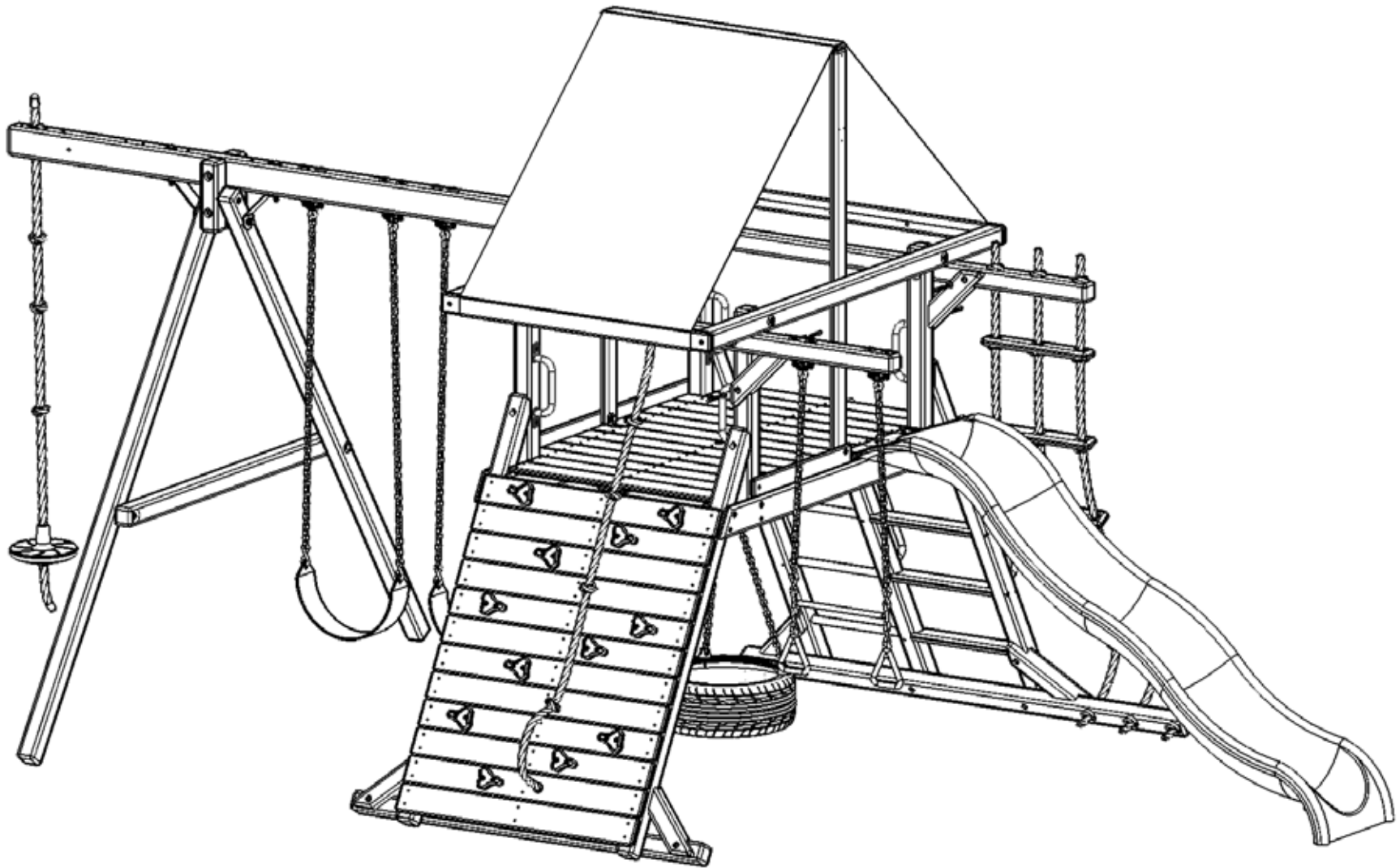



# Wood Roof Assembly

## PARTS NEEDED

- 353-1- 12 5/16" Shor Fan Board- (4)
- 353-2- 43 11/16" Bottom Fan Board- (2)
- 353-4- 10" Center Fan Board- (2)
- 356-6- 56 3/4" Enhd Tarp Board- (2)

## HARDWARE NEEDED

- WR-2- 1 1/2" Coated Deck Screw- (20)
- Q- 1/4" USS Flatwasher- (4)
- G- 1/4" x 4 1/2" Hex Lag Screw- (4)

MAKE 2 FAN ASSEMBLIES

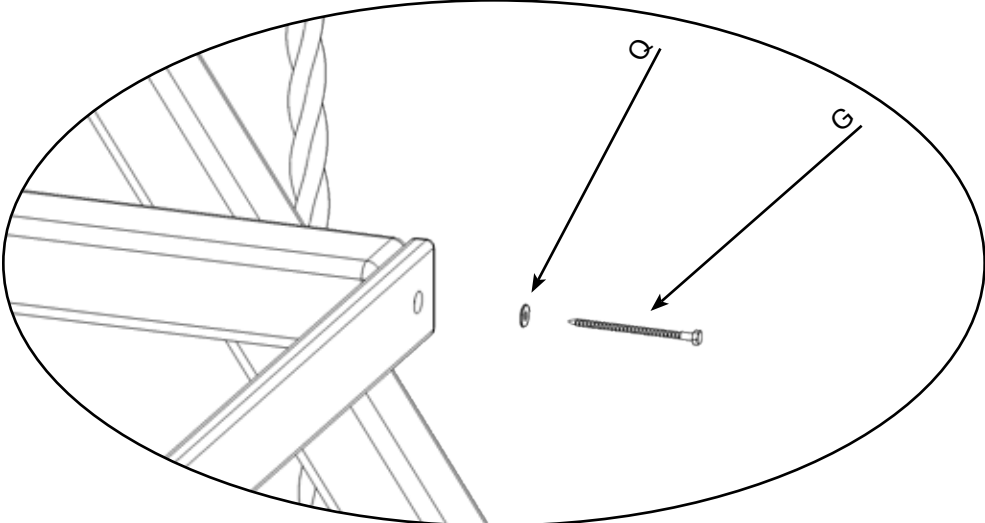
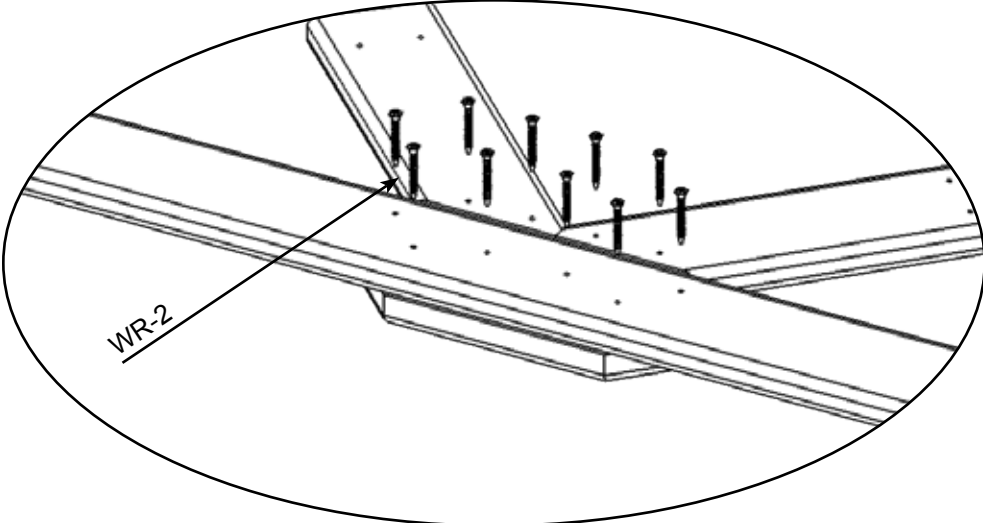
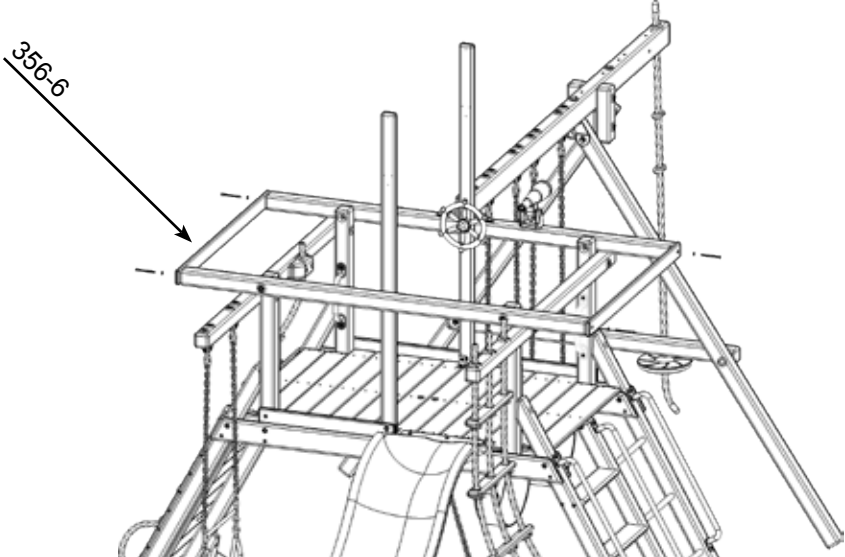
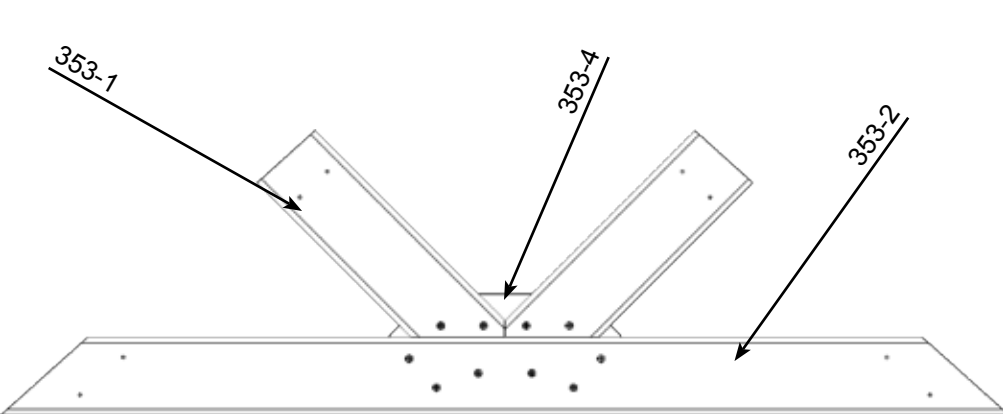

# Wood Roof Install

## PARTS NEEDED

- 353-6- 56 3/4" Roof Supports- (4)
- 353-5- 11 5/8" Peak Facia- (2)

## HARDWARE NEEDED

- WR-5- 3/8" x 3 1/2" Hex Lag Screw- (4)
- WR-6- 3/8" USS Flatwasher- (4)
- WR-4- 2 1/2" Coated Deck Screw- (4)
- WR-3- 2" Coated Deck Screw- (6)

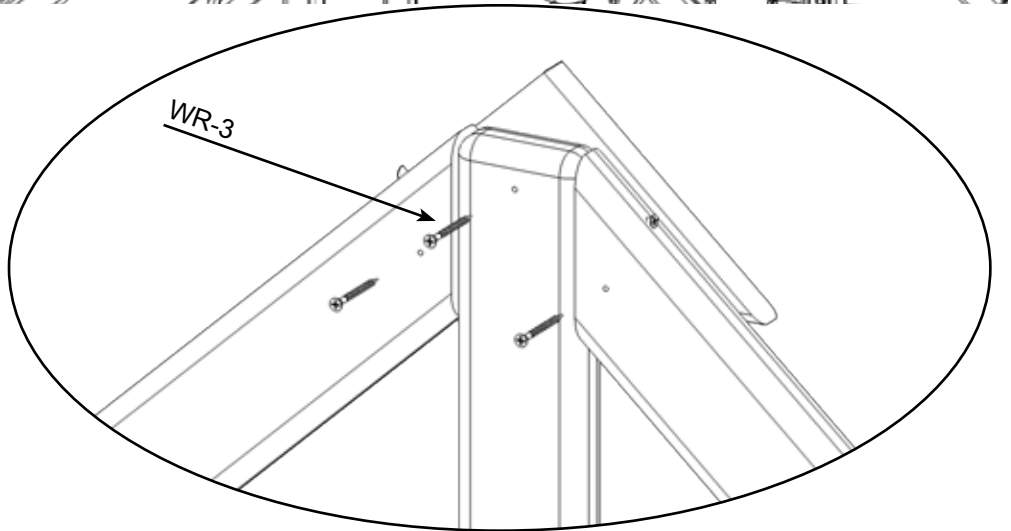
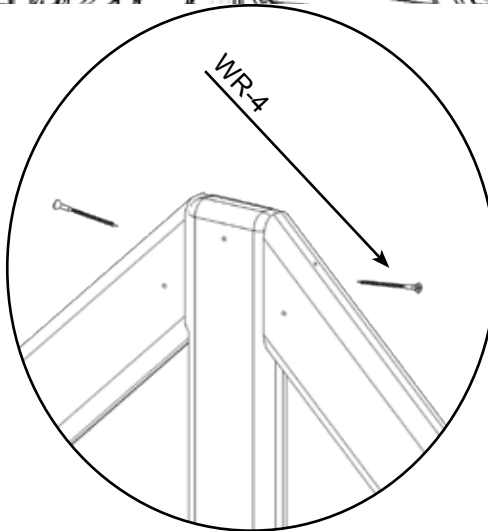
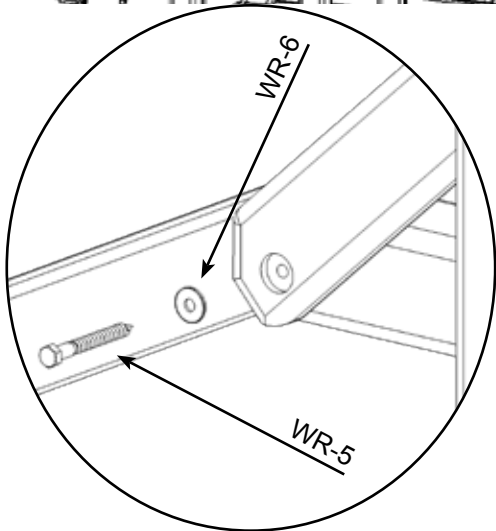
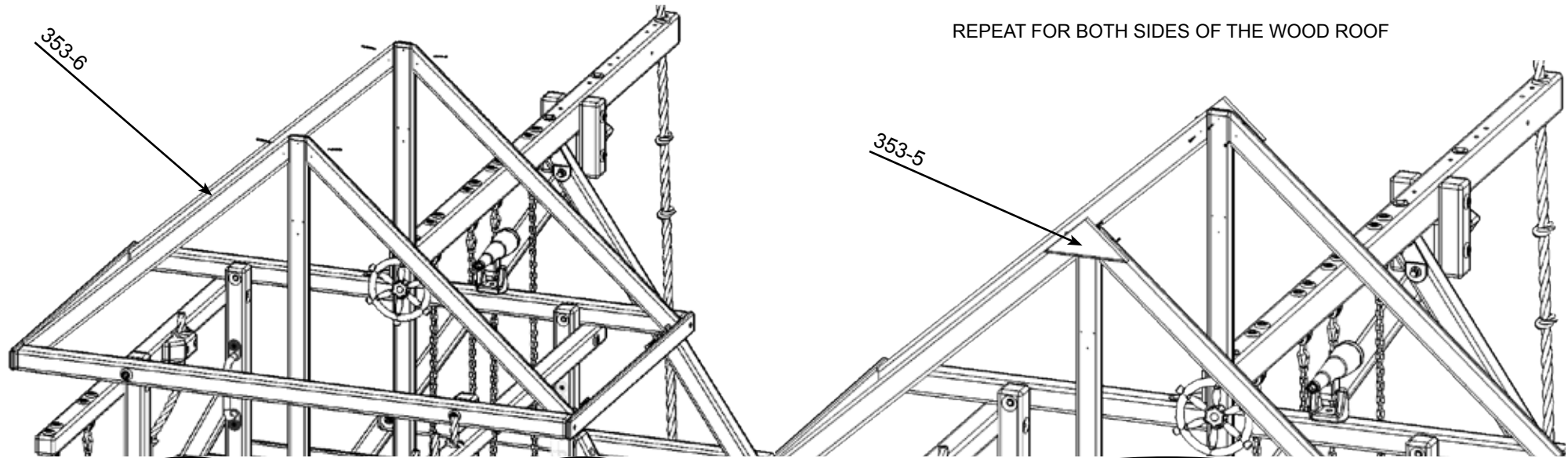

# Wood Roof Install

## PARTS NEEDED

353-8- 56 3/4" Roof Board- (10)  
353-3- 62" Center Wood Roof Support- (2)

## HARDWARE NEEDED

WR-2- 1 1/2" Coated Deck Screw- (40)  
WR-1- 1 1/4" Coated Deck Screw- (10)

REPEAT FOR BOTH SIDES OF THE WOOD ROOF. WOOD ROOF BOARDS OVERHANG SUPPORTS BY 3 3/8".

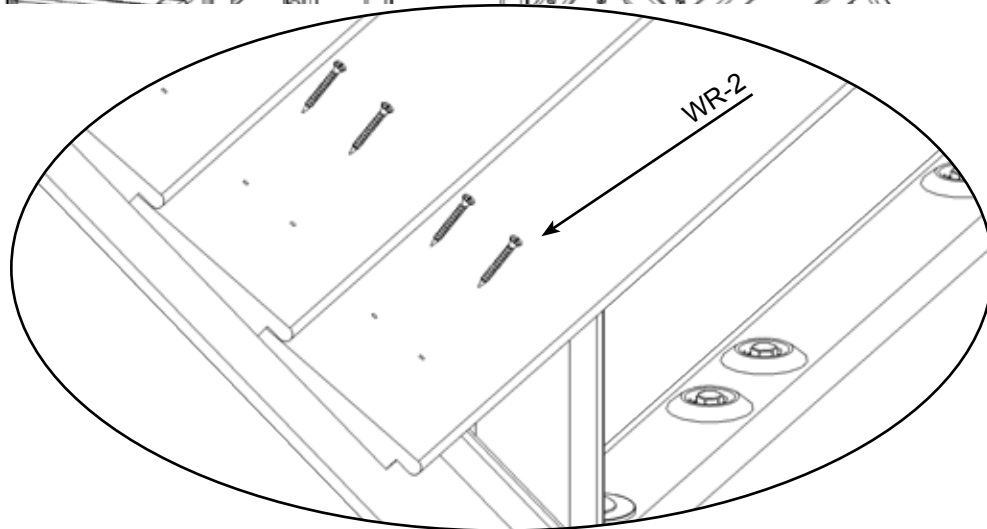
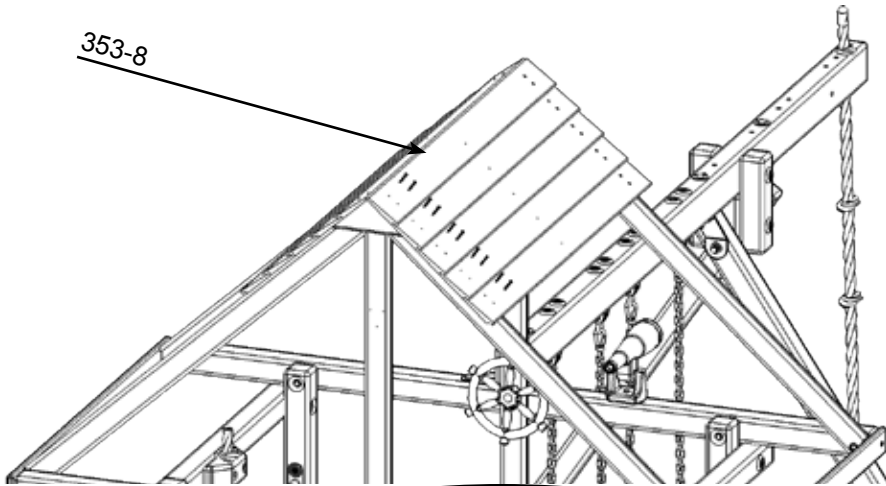

REPEAT FOR BOTH SIDES OF THE WOOD ROOF

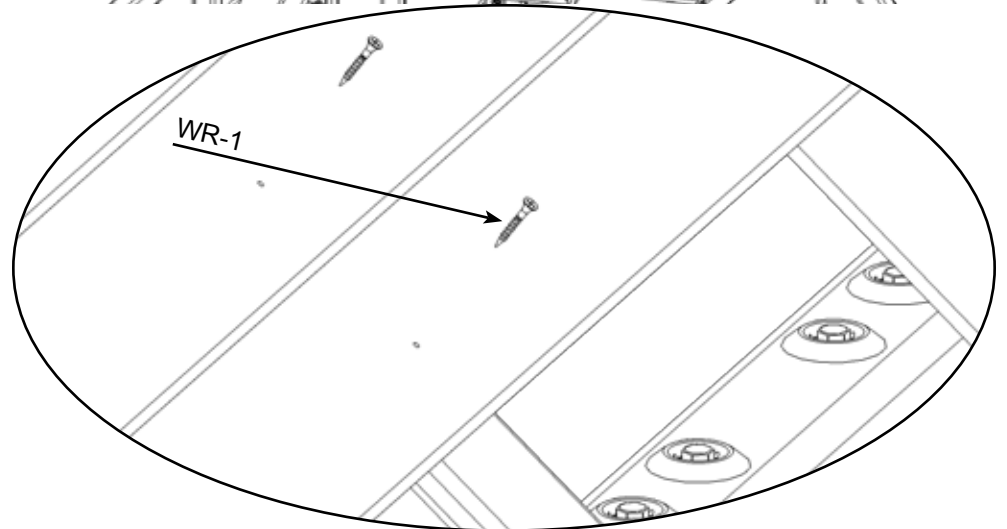
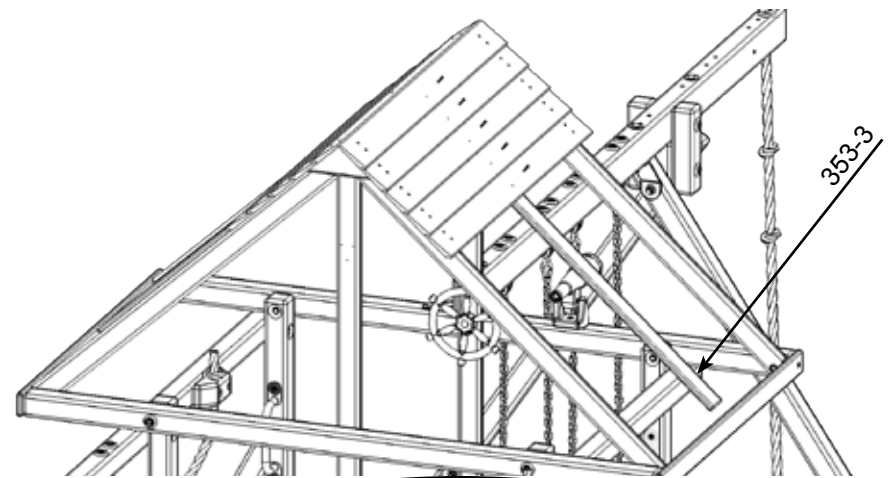

# Wood Roof Install

## PARTS NEEDED

353-8- 56 3/4" Roof Board- (16)  
353-7- 56 3/4" Roof Board Ripped- (2)

## HARDWARE NEEDED

WR-2- 1 1/2" Coated Deck Screw- (72)  
WR-1- 1 1/4" Coated Deck Screw- (18)

REPEAT FOR BOTH SIDES OF THE WOOD ROOF

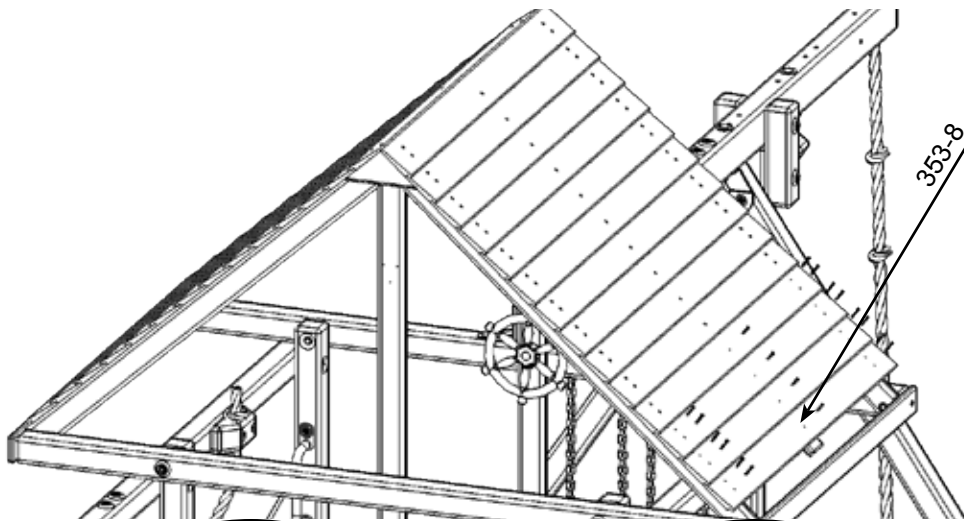

REPEAT FOR BOTH SIDES OF THE WOOD ROOF

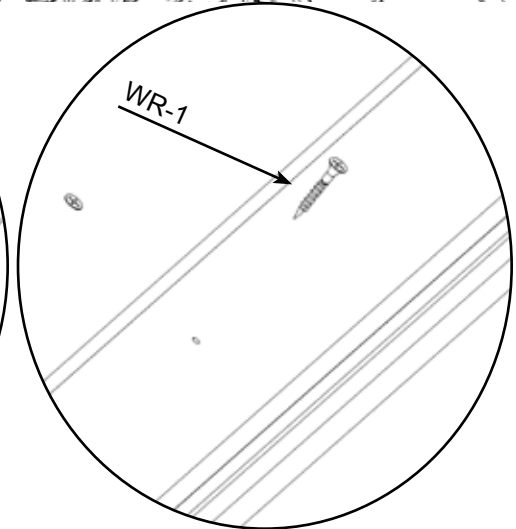
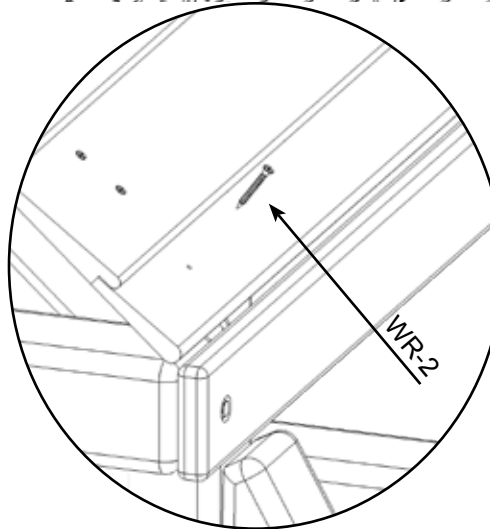
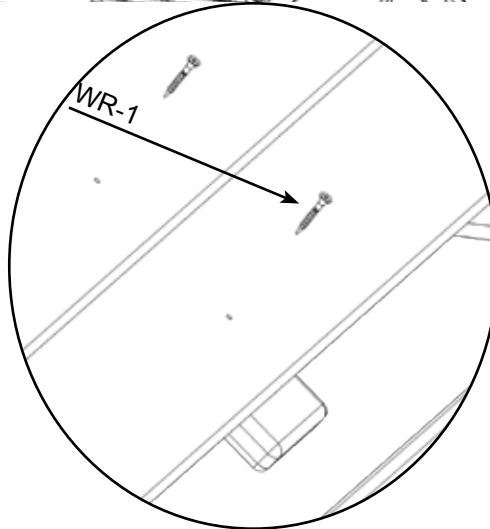
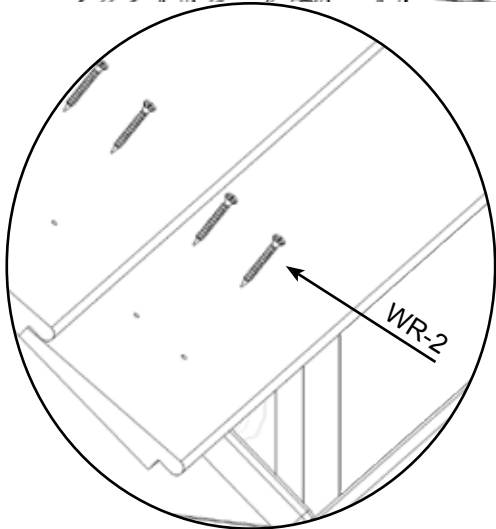
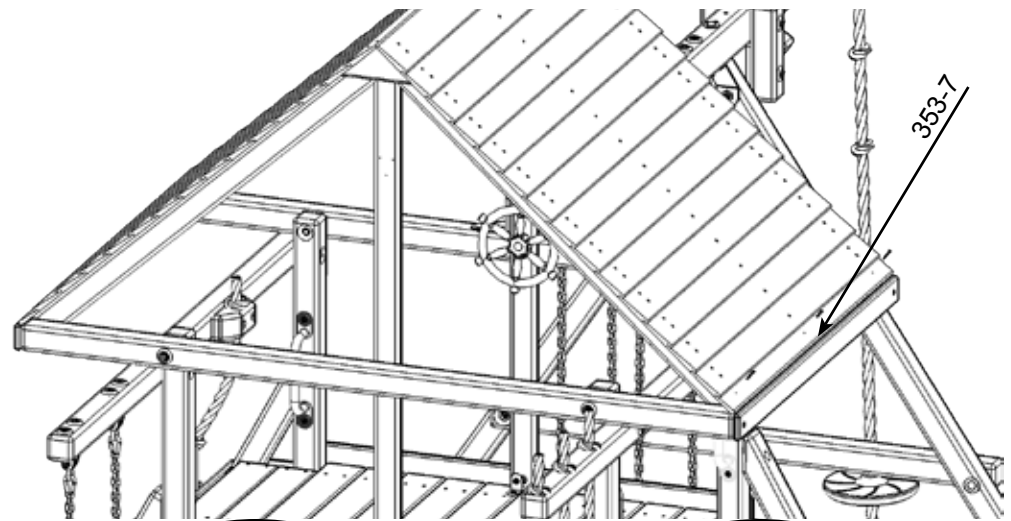

# Wood Roof Install

## PARTS NEEDED

Fan Assembly-

(1)

## HARDWARE NEEDED

WR-2- 1 1/2" Coated Deck Screw-

(16)

WR-4- 2 1/2" Coated Deck screw-

(6)

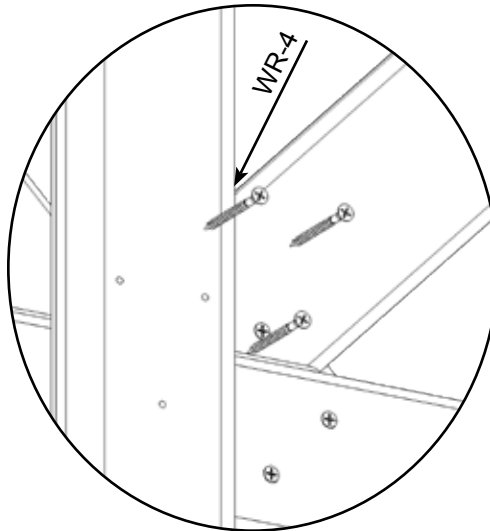
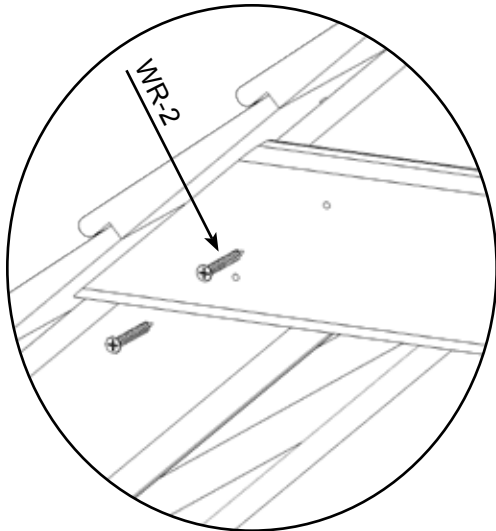
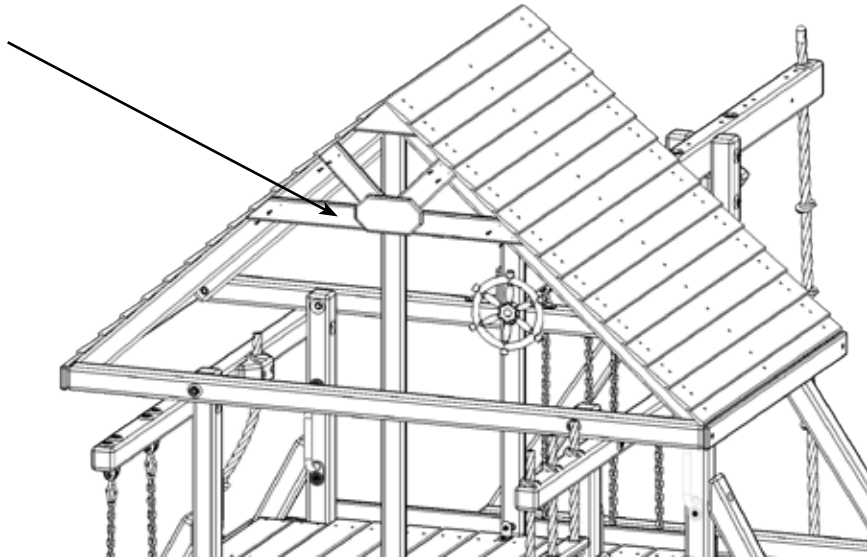

FINISHED WOOD ROOF ASSEMBLY. RAIL OPTIONS ARE NEXT.  
FOR TREEHOUSE PANELS SKIP THE OPEN AIR OPTION AND  
GO TO THE FILLED PANEL OPTION.

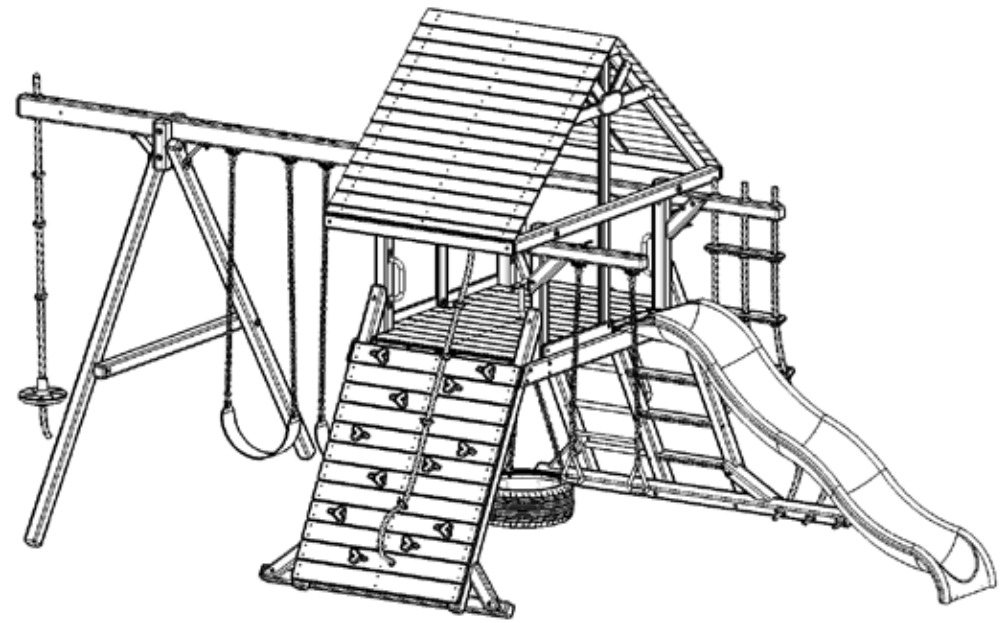

# Tic Tac Toe Assembly (Works for both Open Air and Filled Panel Install)

## PARTS NEEDED

- 356-1- 22" Tic Tac Toe Board- (2)
- 356-M- Tic Tac Toe- (1)
- 356-4- 32" Tic Tac Toe Spindle- (2)

## HARDWARE NEEDED

- B- 1 1/2" Coated Deck Screw- (4)

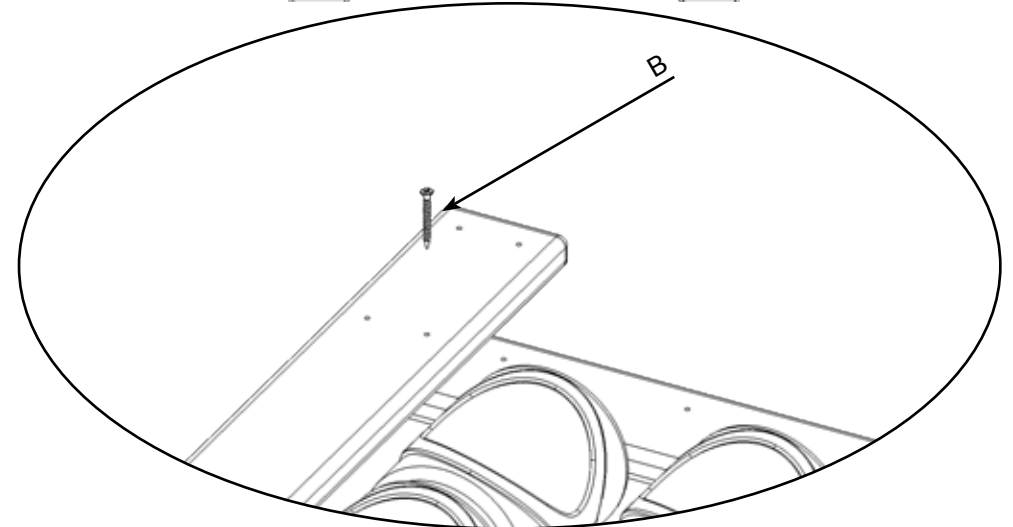
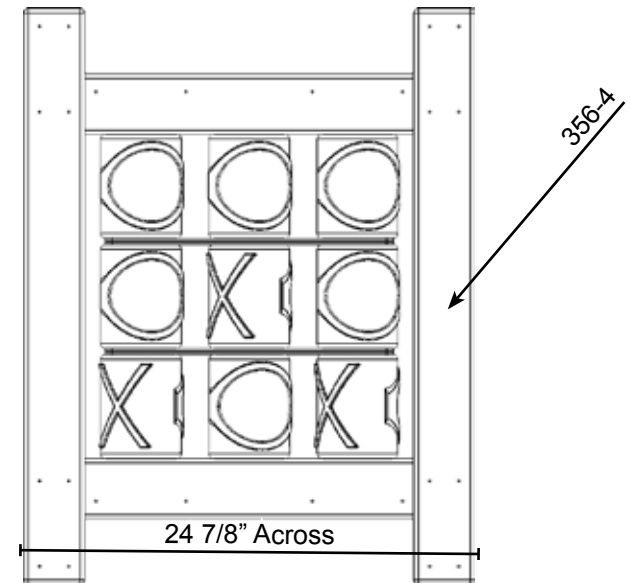
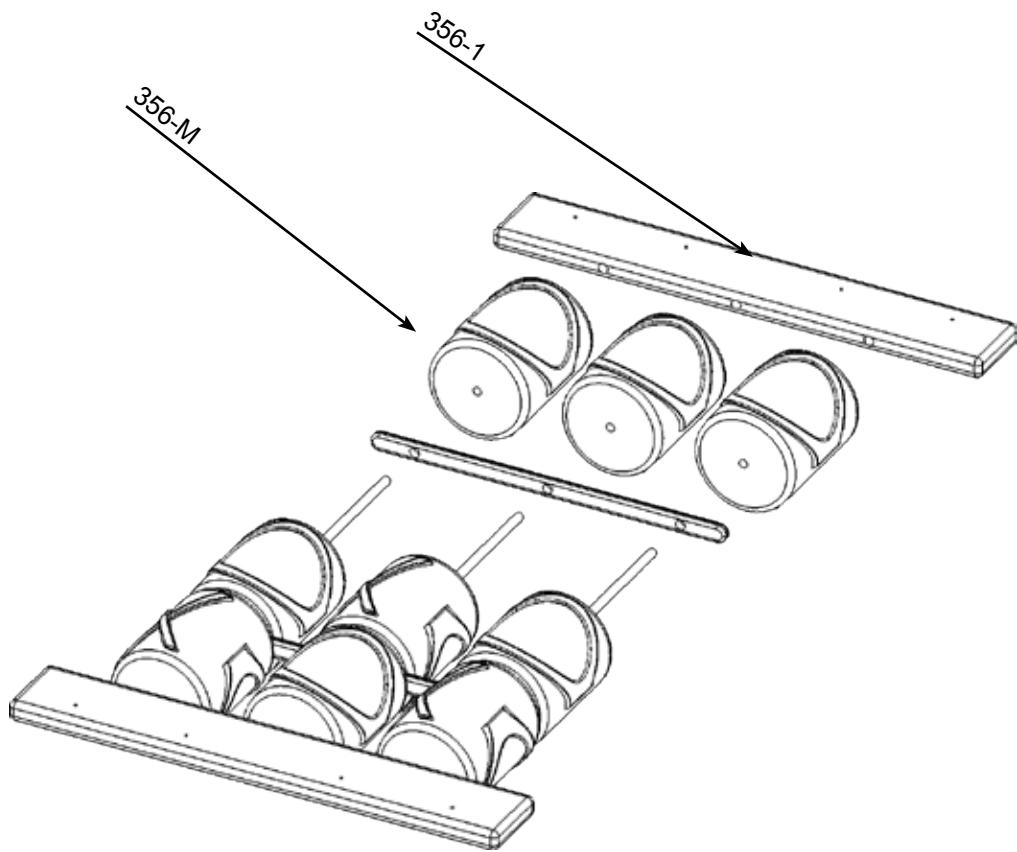

# Open Rail Install (Skip for Treehouse Rail Install)

## PARTS NEEDED

356-3- 32" Rail Spindle-

(8)

## HARDWARE NEEDED

B- 1 1/2" Coated Deck Screw-

(32)

RAILS ARE 2 1/2" APART STARTING FROM THE CORNER POST

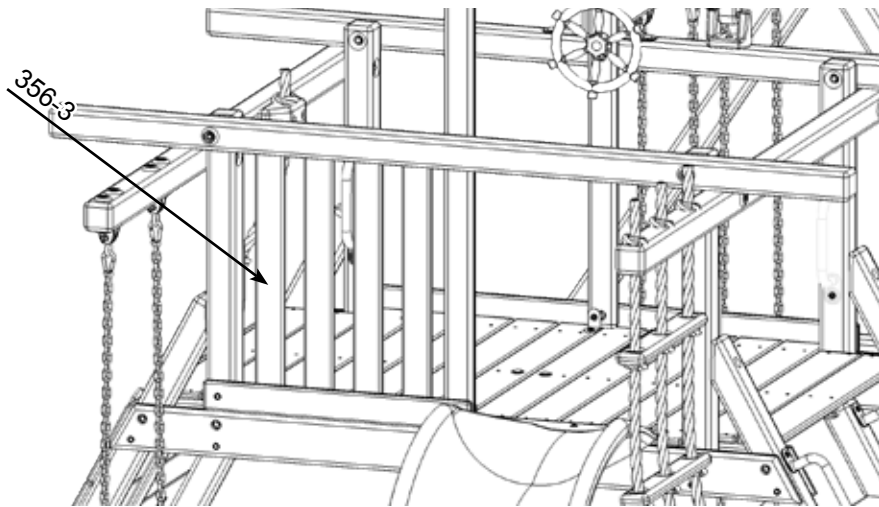

RAILS ARE 2 1/2" APART STARTING FROM THE CORNER POST

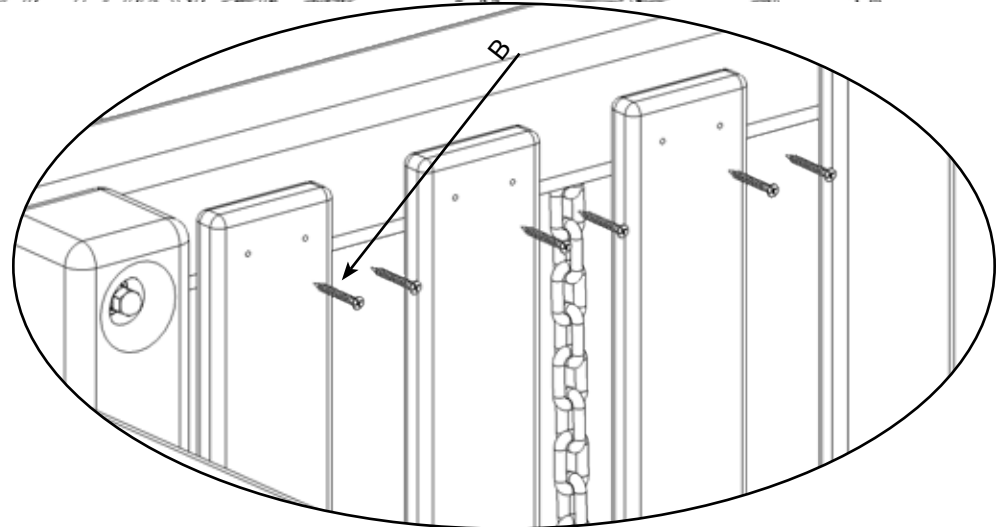
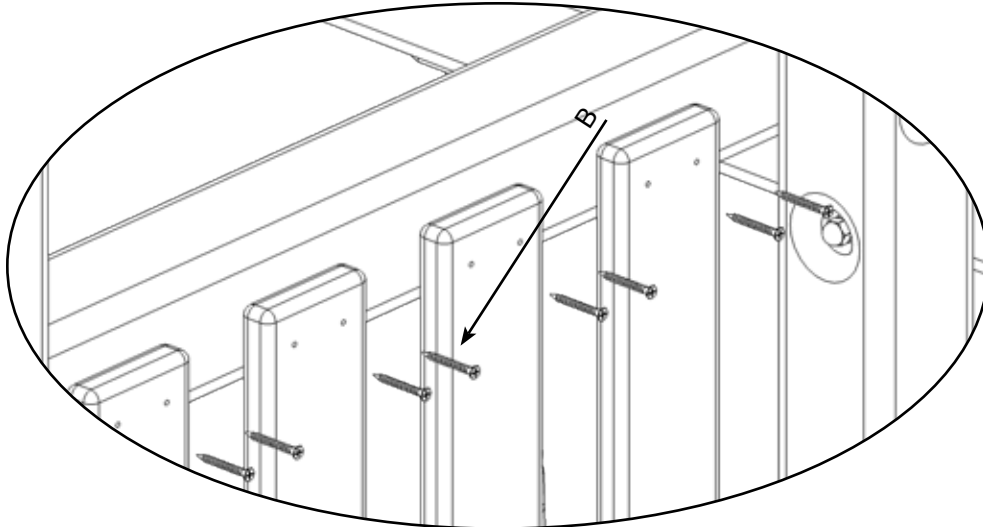
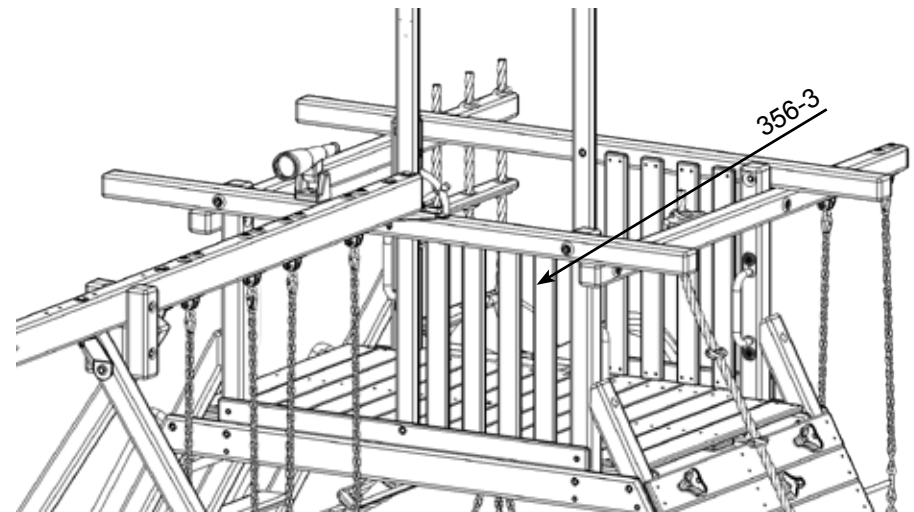

# Open Rail Install (Installation Complete)

## PARTS NEEDED

Tic Tac Toe Assembly-

(1)

## HARDWARE NEEDED

B- 1 1/2" Coated Deck Screw-

(8)

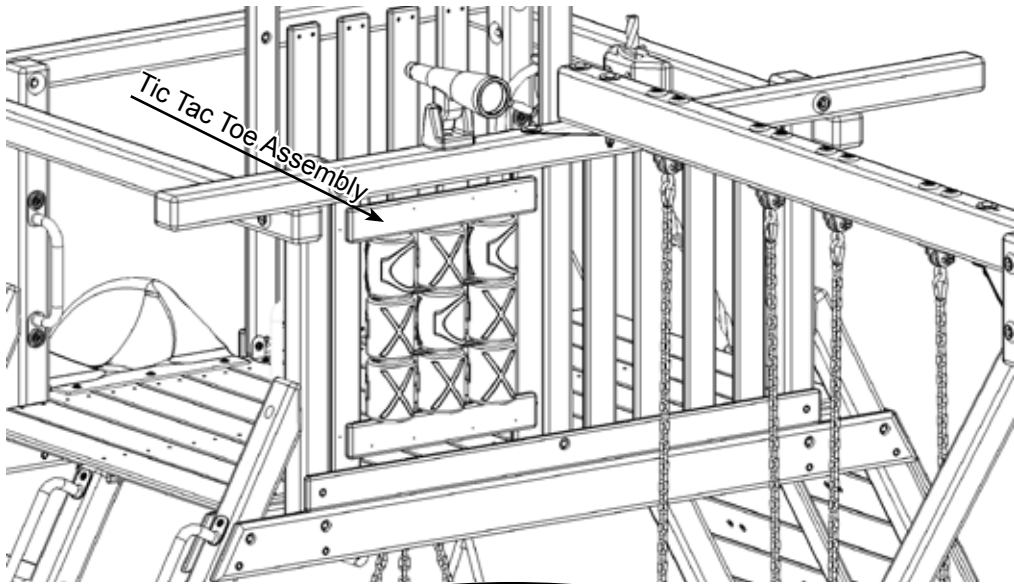

FINISHED TARP ASSEMBLY WITH OPEN AIR RAILS

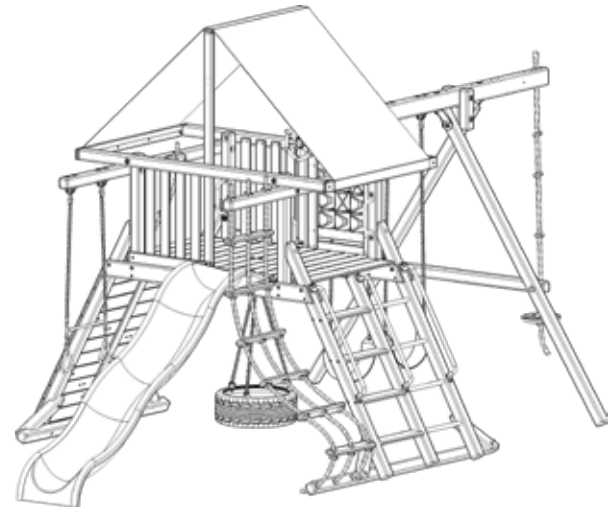

FINISHED WOOD ROOF ASSEMBLY WITH OPEN AIR RAILS

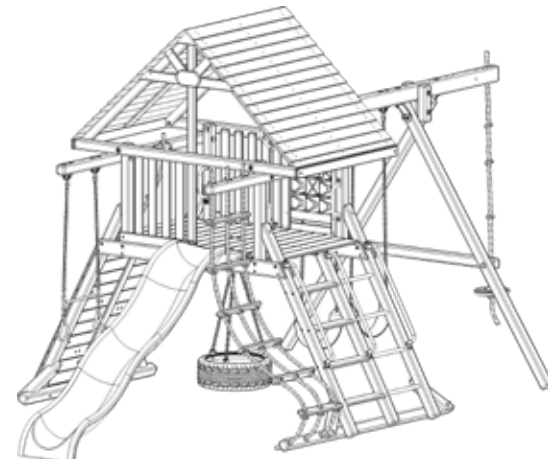
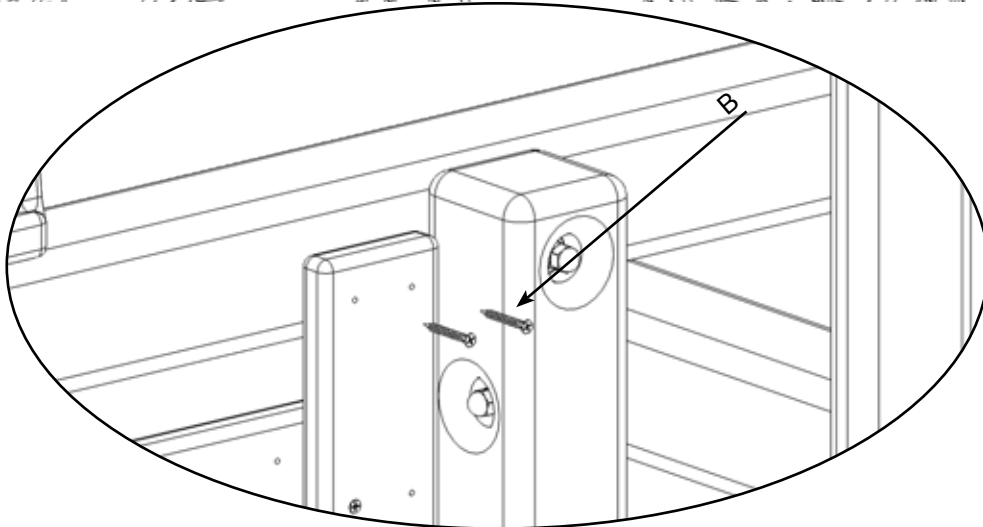



# Treehouse Panel Rail Option

## PARTS NEEDED

- Tic Tac Toe Assembly- (1)
- 354-15- 6 3/4" Short Wide Picket-18- (2)
- 354-1- 6 3/4" Short Picket-17- (8)

## HARDWARE NEEDED

- B- 1 1/2" Coated Deck Screw- (8)
- TH-1- 1 1/2" Coated Deck Screw- (40)

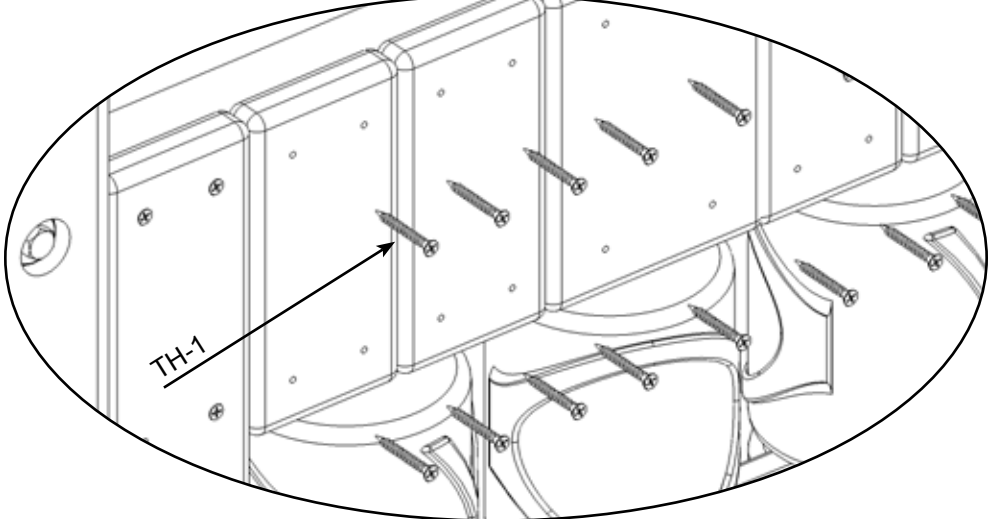
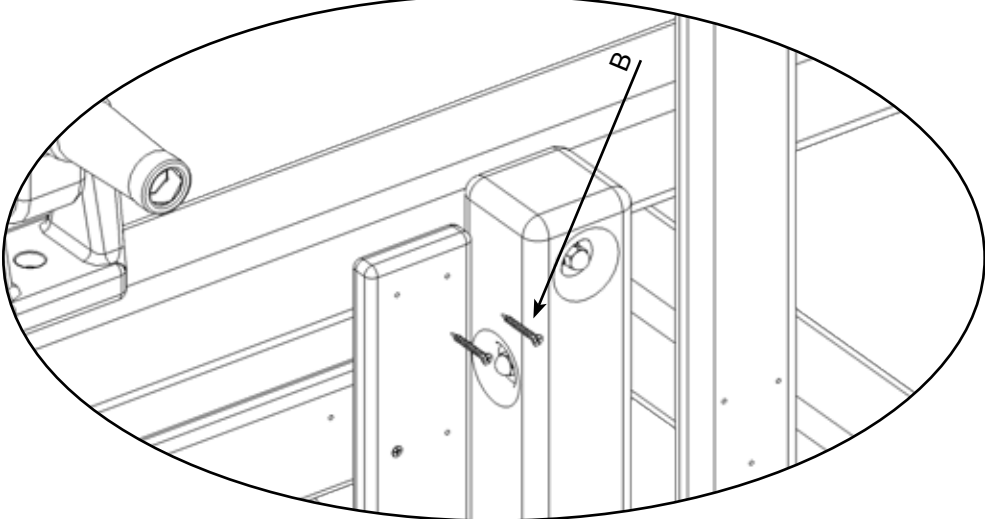
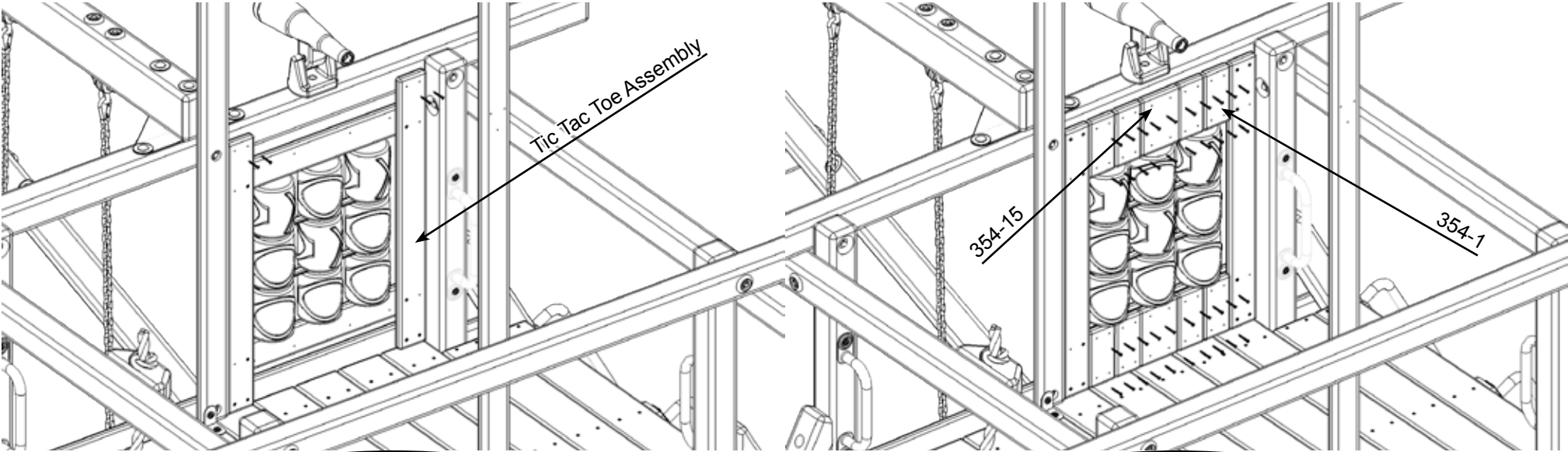

# Treehouse Panel Rail Option

## PARTS NEEDED

354-13- 32" Rail Spindle-	(4)
354-20- 32" Panel Spindle-	(2)
356-3- 32" Rail Spindle-	(8)

## HARDWARE NEEDED

B- 1 1/2" Coated Deck screw-	(32)
TH-1- 1 1/2" Coated Deck Screw-	(24)

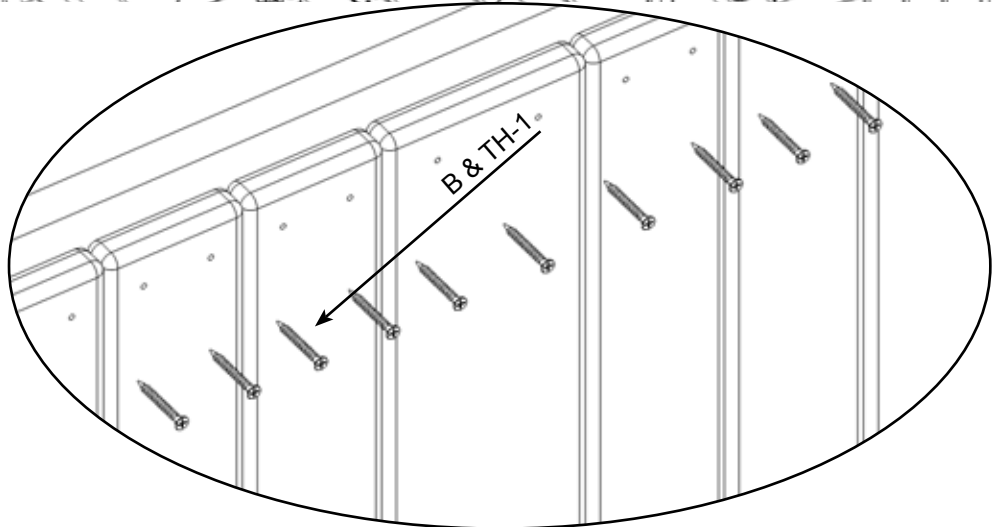
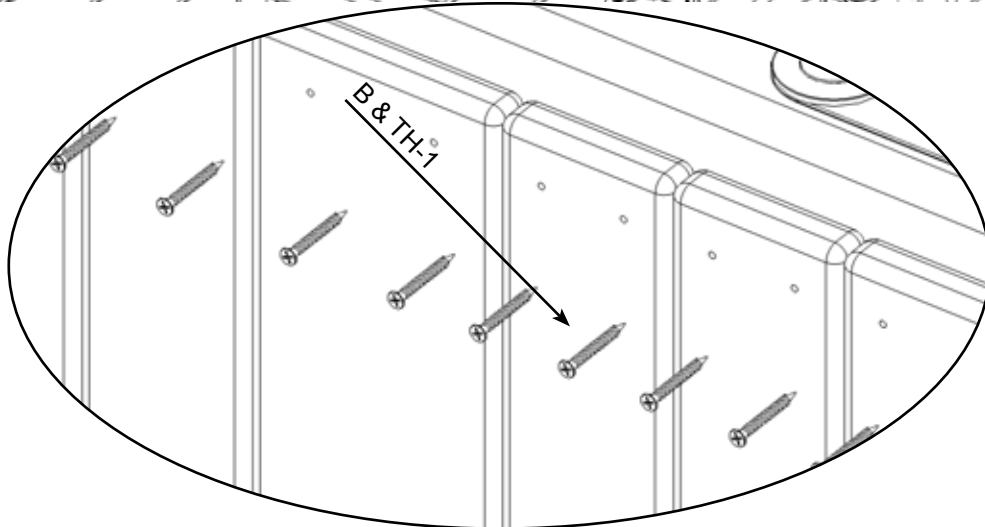
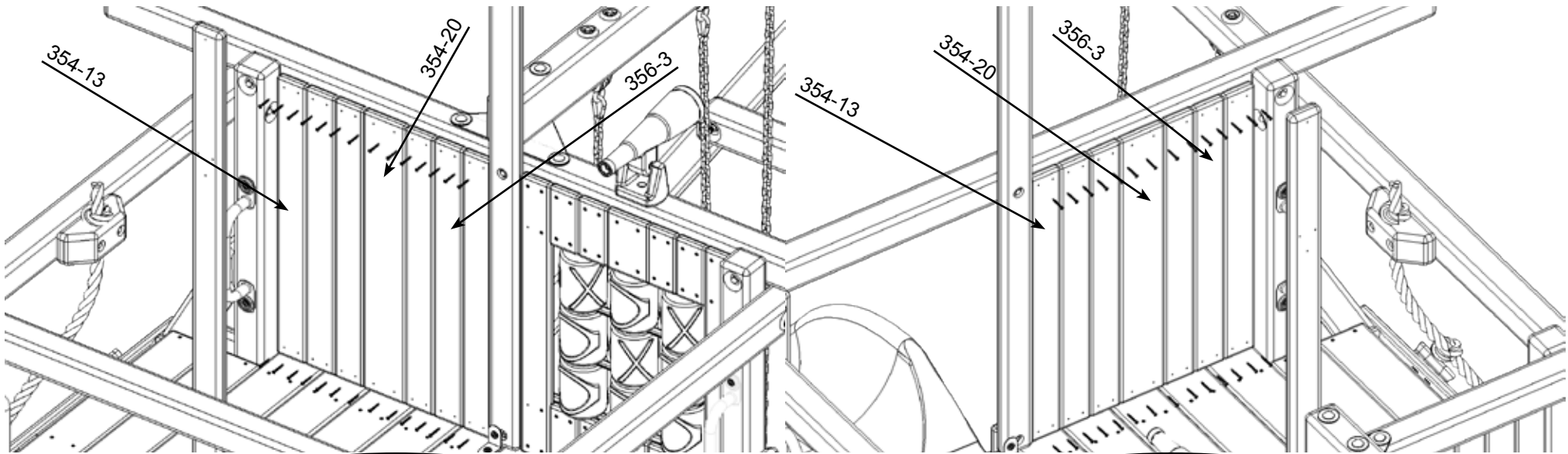

# Treehouse Panel Install (REPEAT FOR BOTH SIDES OF UNIT)

## PARTS NEEDED

354-19- 28" Panel Board 11- (4)  
354-8- 6 3/4" Panel Board 10- (4)

## HARDWARE NEEDED

TH-1- 1 1/2" Coated Deck Screw- (24)

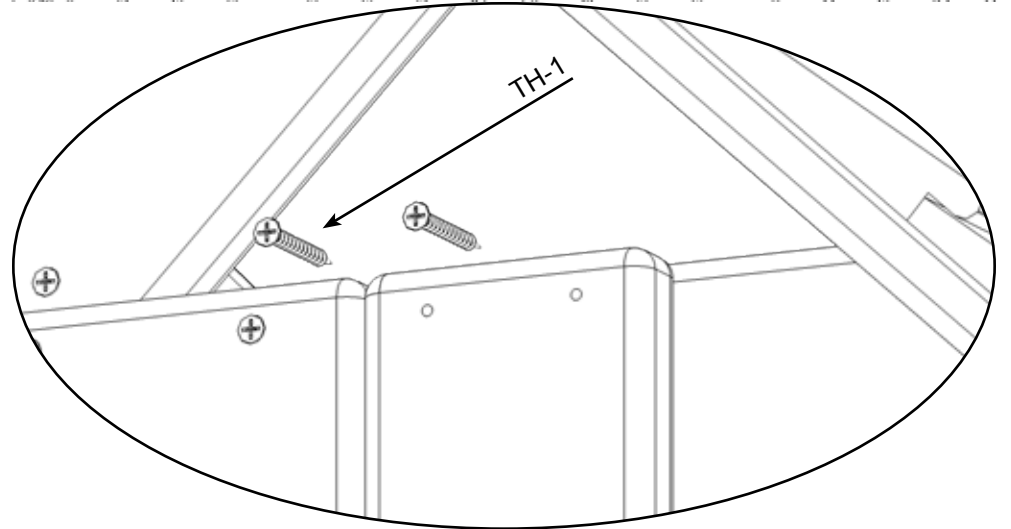
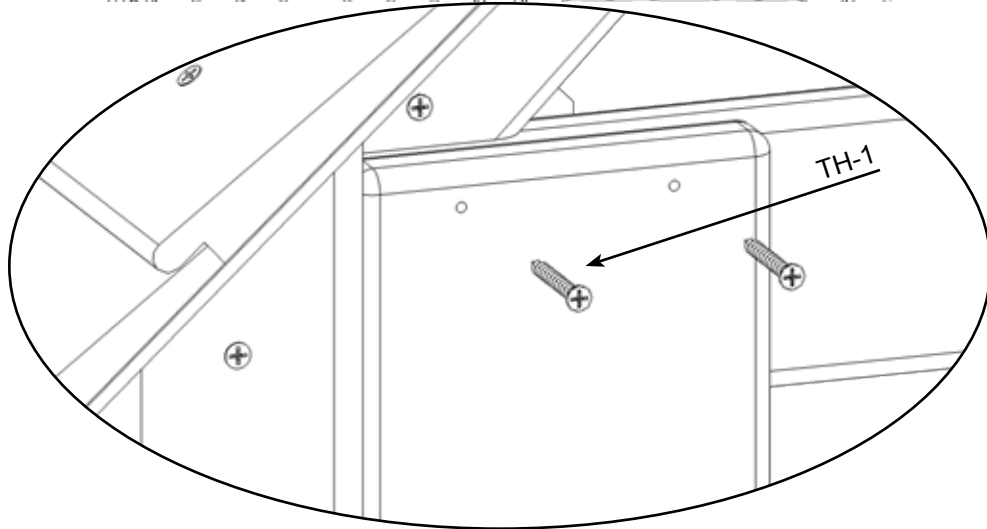
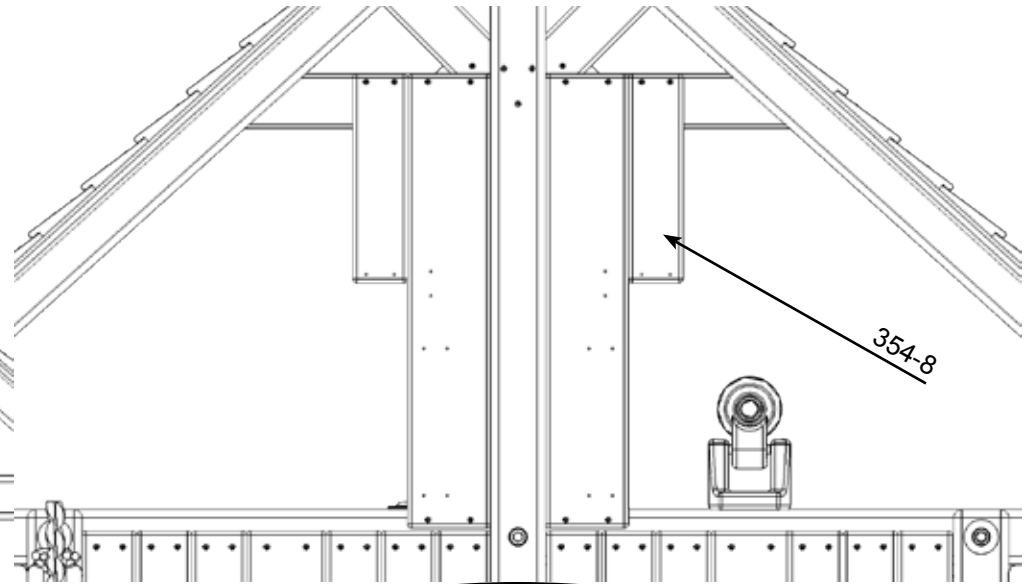
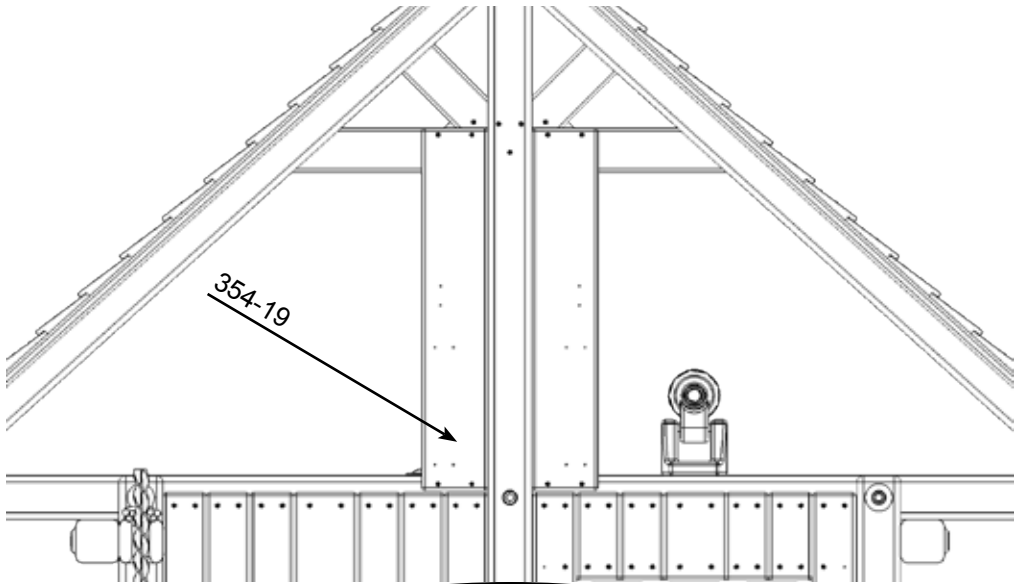

# Treehouse Panel Install (REPEAT FOR BOTH SIDES OF UNIT)

## PARTS NEEDED

- 354-9- 12 7/8" Panel Board-9 (4)
- 354-12- 16" Window Top- (4)

## HARDWARE NEEDED

- TH-1- 1 1/2" Coated Deck Screw- (16)

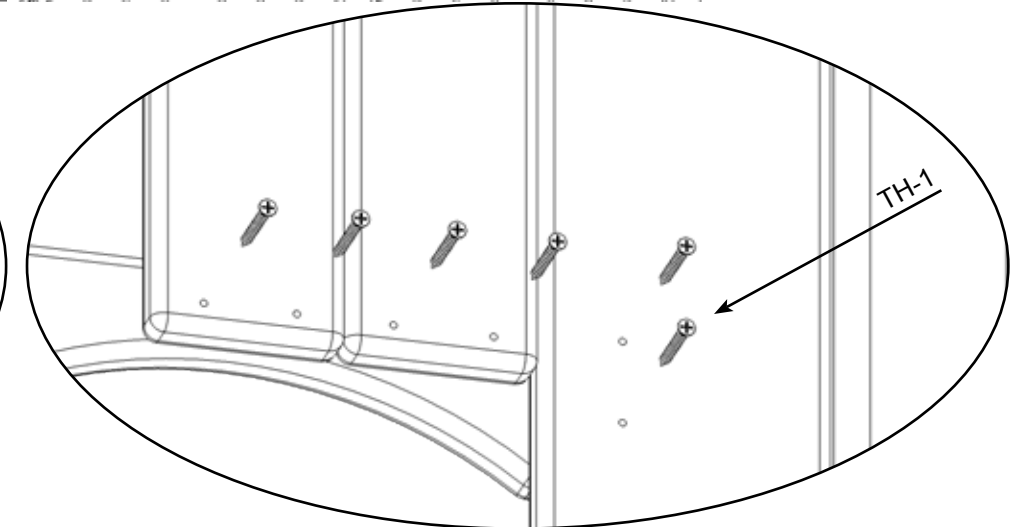
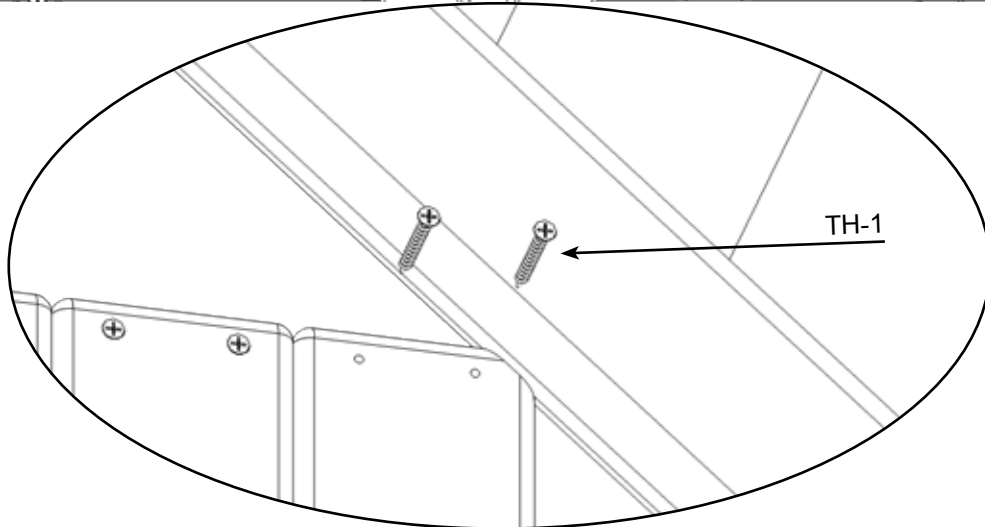
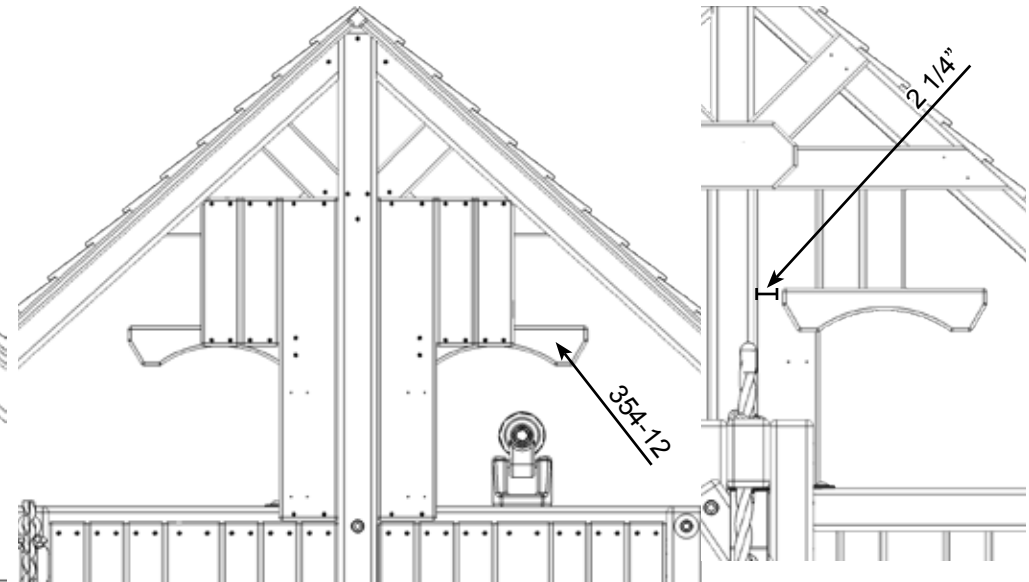
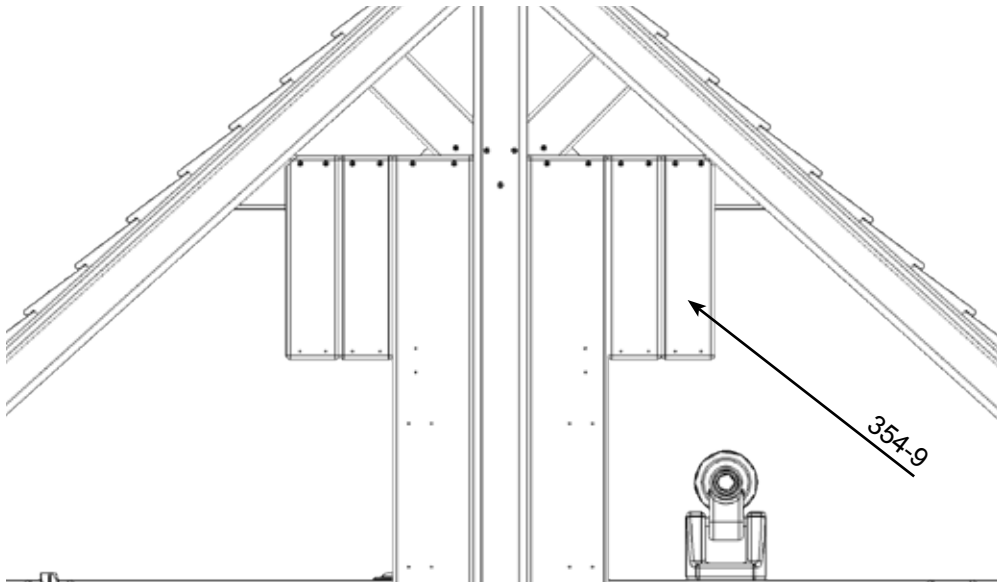

# Treehouse Panel Install (REPEAT FOR BOTH SIDES OF UNIT)

## PARTS NEEDED

- 354-7- 12 1/2" Panel Board-8- (4)
- 354-18- 24 9/16" Panel Board-7- (4)

## HARDWARE NEEDED

- TH-1- 1 1/2" Coated Deck Screw- (24)

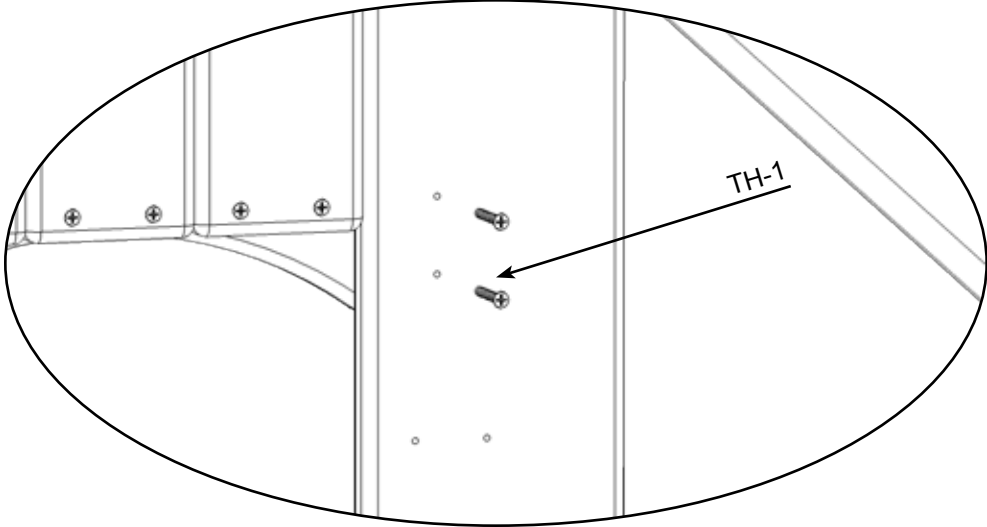
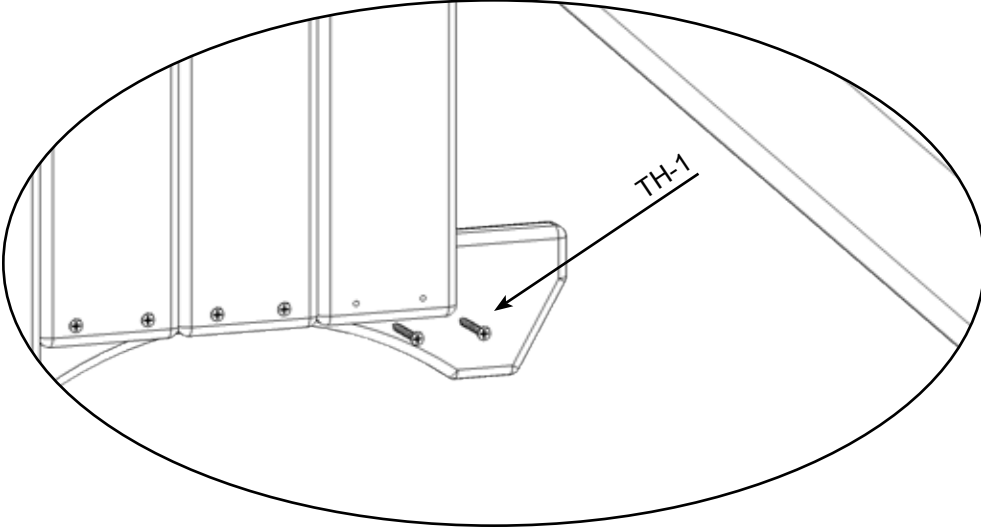
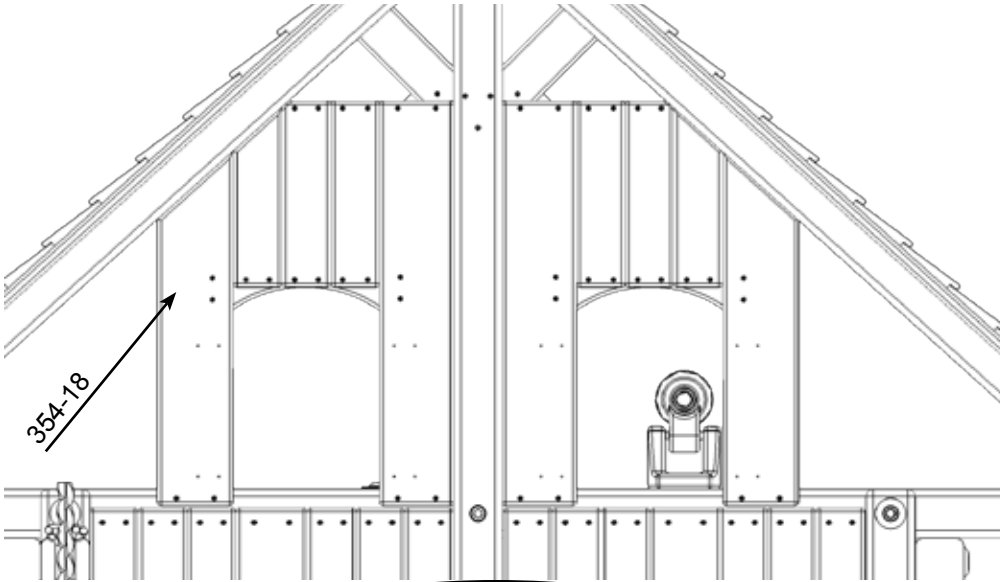
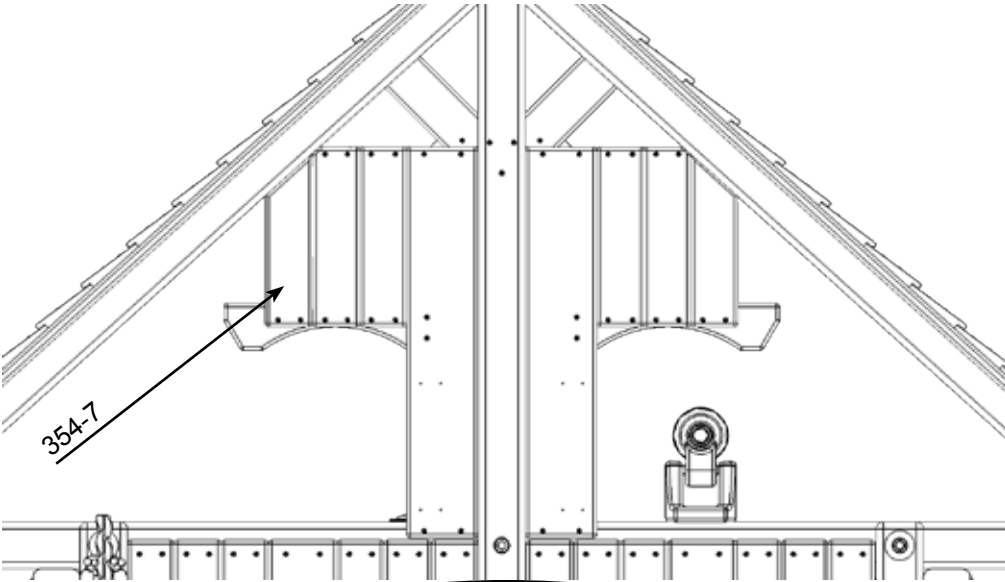

# Treehouse Panel Install (REPEAT FOR BOTH SIDES OF UNIT)

## PARTS NEEDED

354-17- 19 7/8" Panel Board-6- (4)  
354-11- 14 1/2" Panel Board-4- (4)

## HARDWARE NEEDED

TH-1- 1 1/2" Coated Deck Screw- (16)

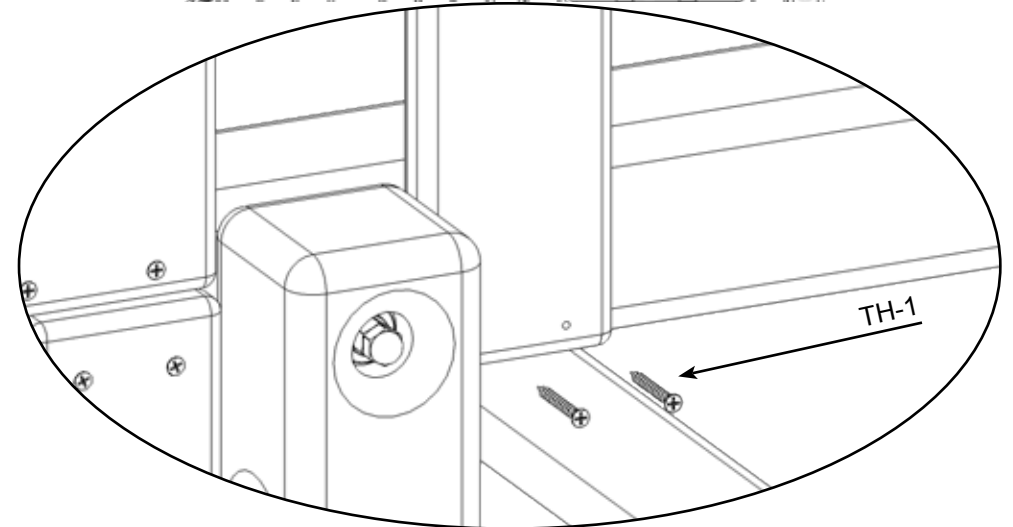
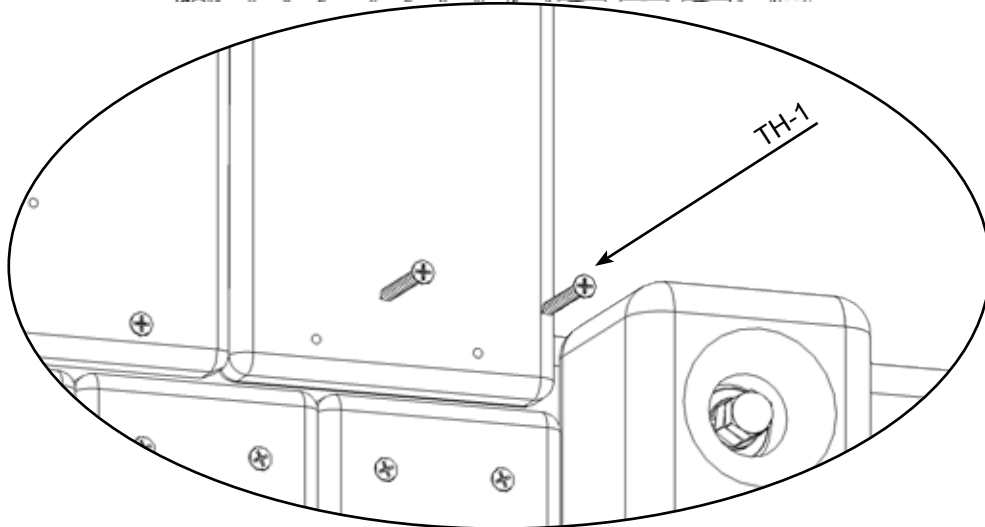
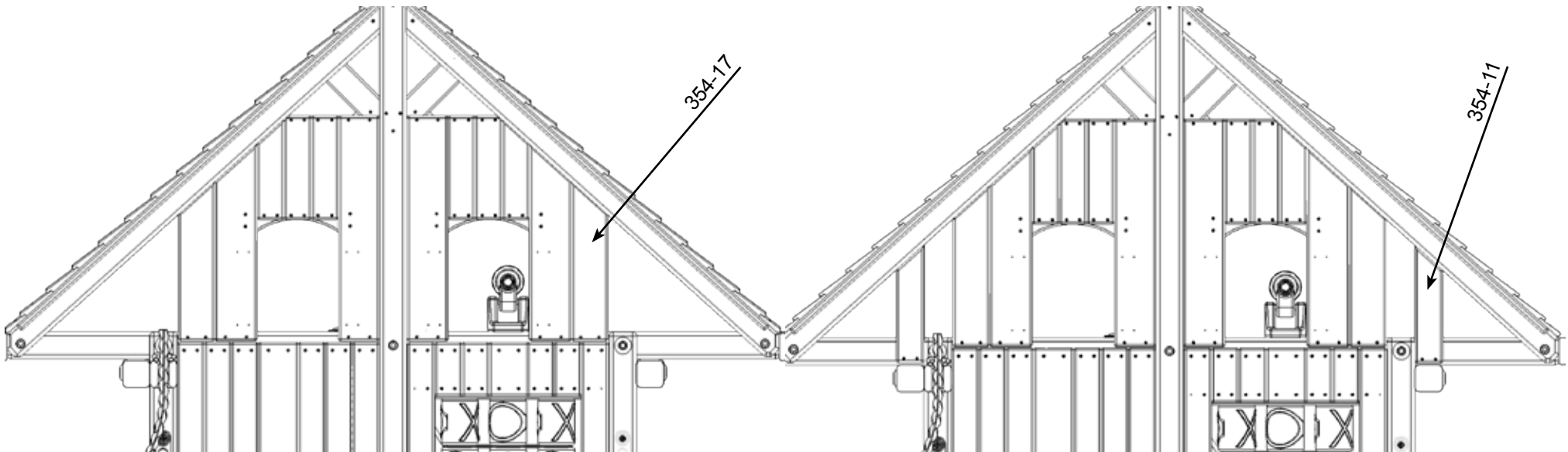

# Treehouse Panel Install (REPEAT FOR BOTH SIDES OF UNIT)

## PARTS NEEDED

354-3- 10 1/2" Panel Board-12- (4)  
354-4- 11 1/2" Panel Board-3- (4)

## HARDWARE NEEDED

TH-1- 1 1/2" Coated Deck Screw- (24)

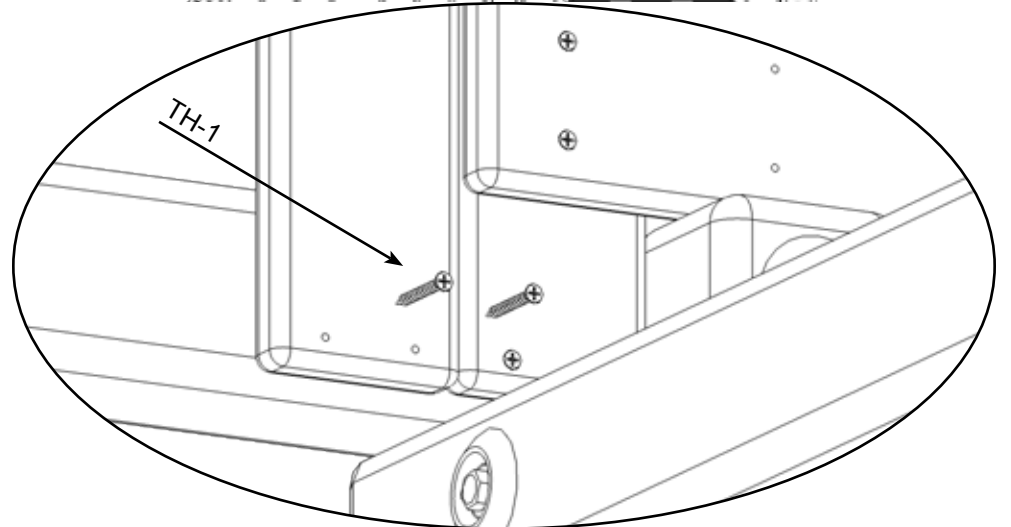
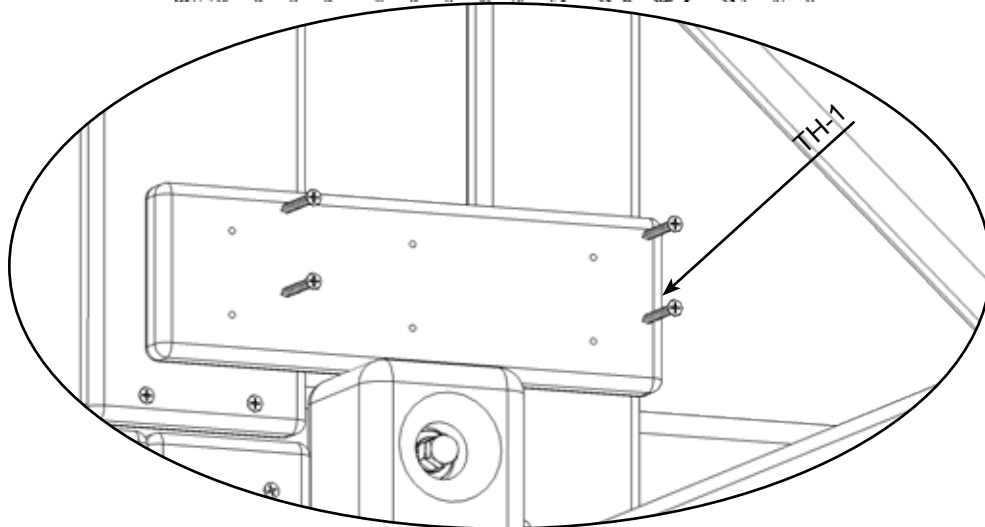
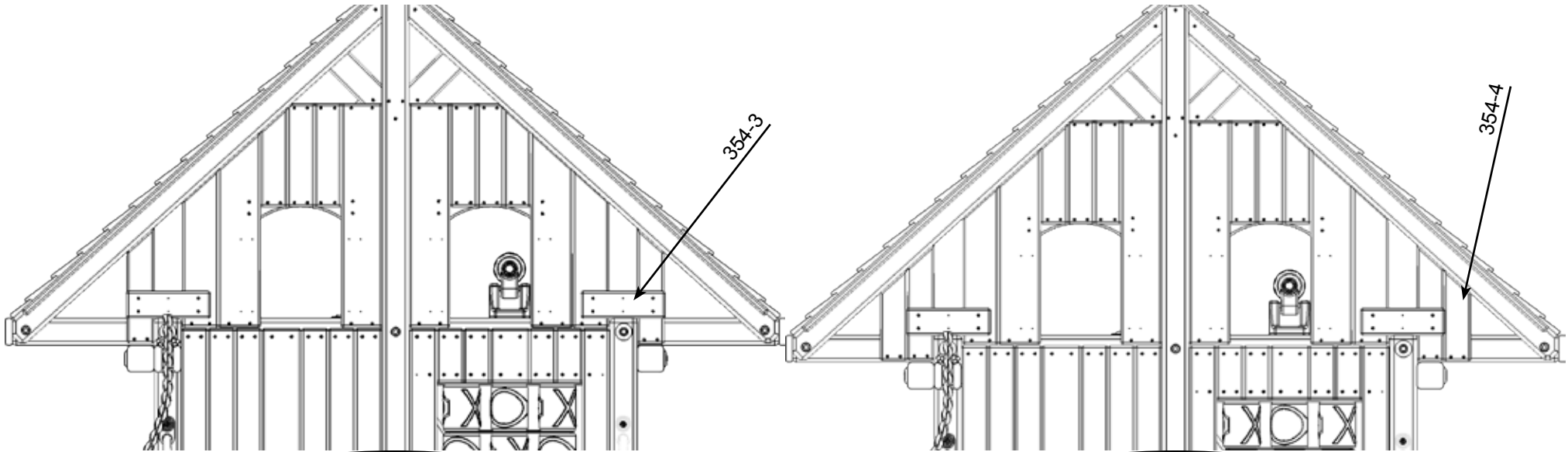

# Treehouse Panel Install (REPEAT FOR BOTH SIDES OF UNIT)

## PARTS NEEDED

354-2- 8 3/8" Panel Board-2- (4)  
354-16- 5 15/16" Panel Board-1- (4)

## HARDWARE NEEDED

TH-1- 1 1/2" Coated Deck Screw- (16)

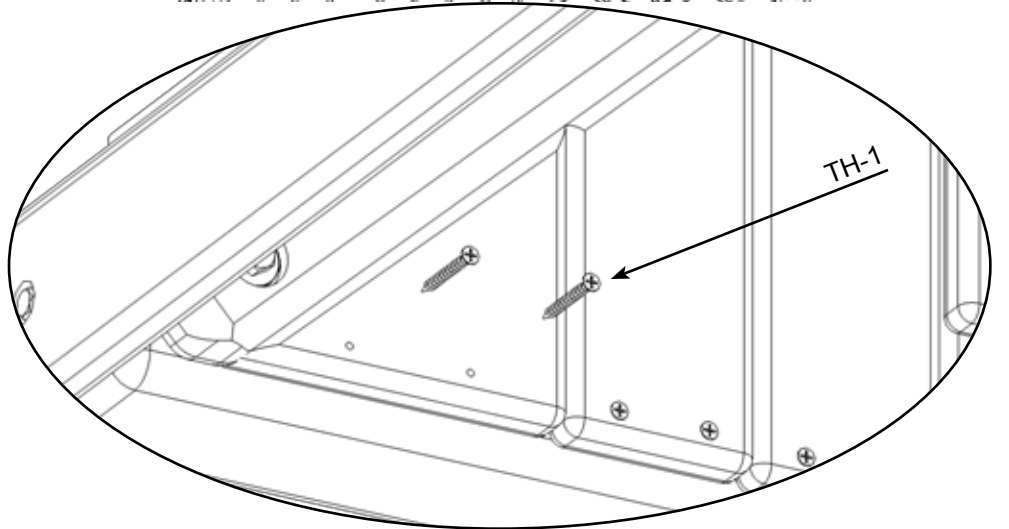
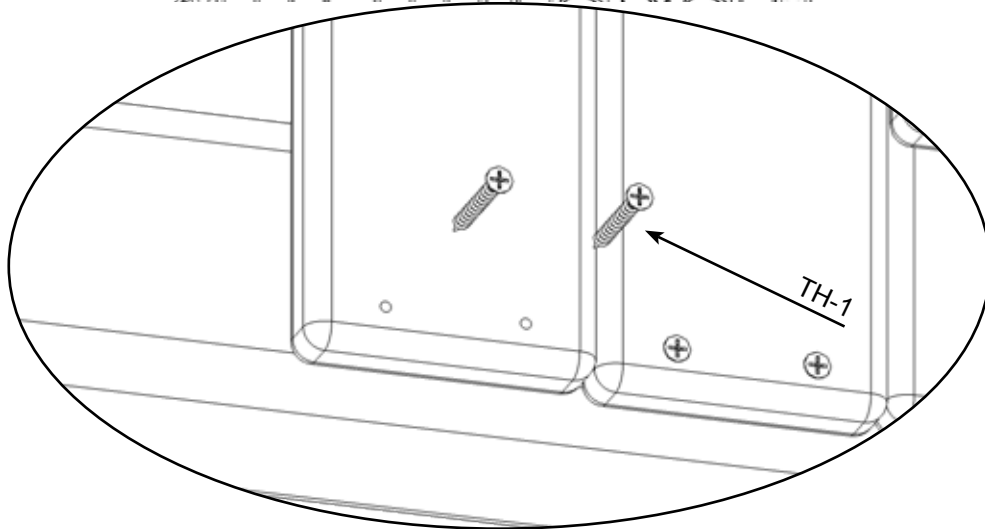
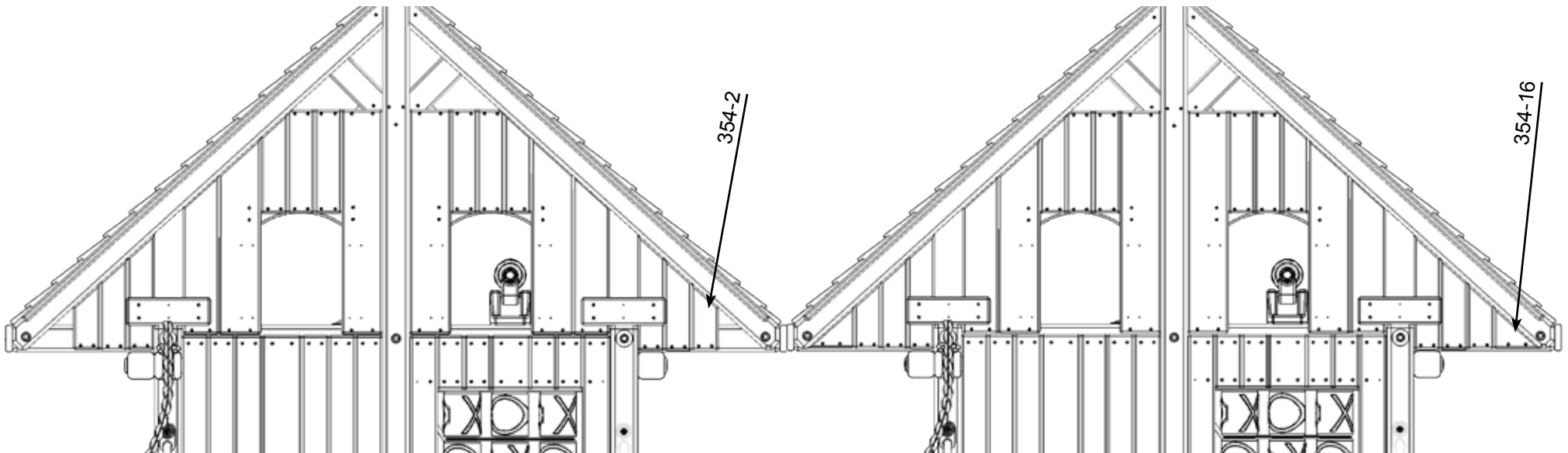



# Treehouse Panel Install (REPEAT FOR BOTH SIDES OF UNIT)

## PARTS NEEDED

354-10- 14 1/8" Panel Board-10- (4)  
354-14- 48 5/8" Upper Support- (4)

## HARDWARE NEEDED

TH-1- 1 1/2" Coated Deck Screw- (88)

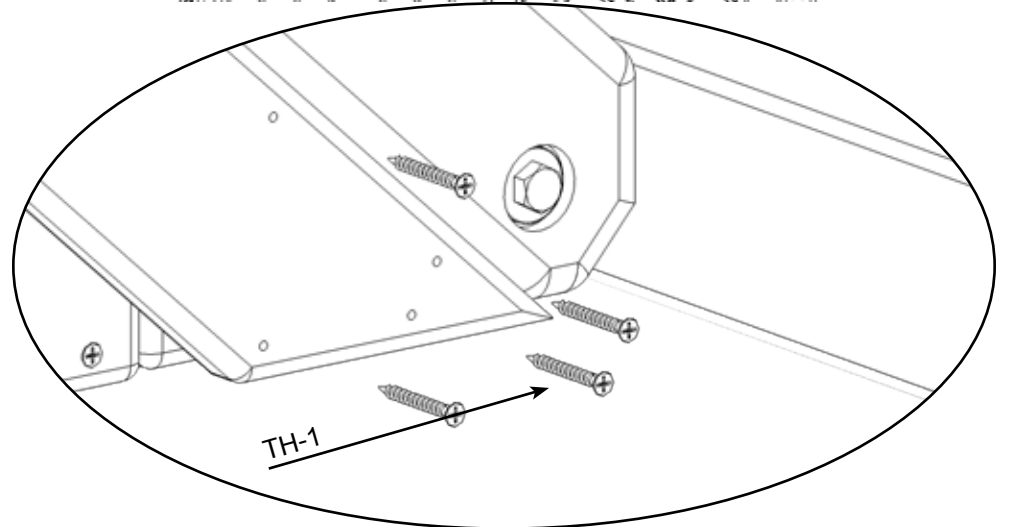
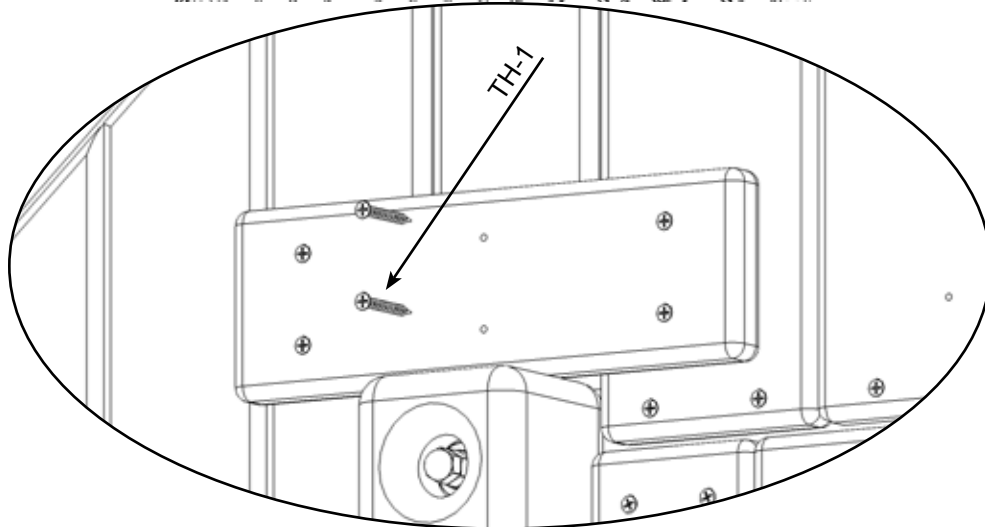
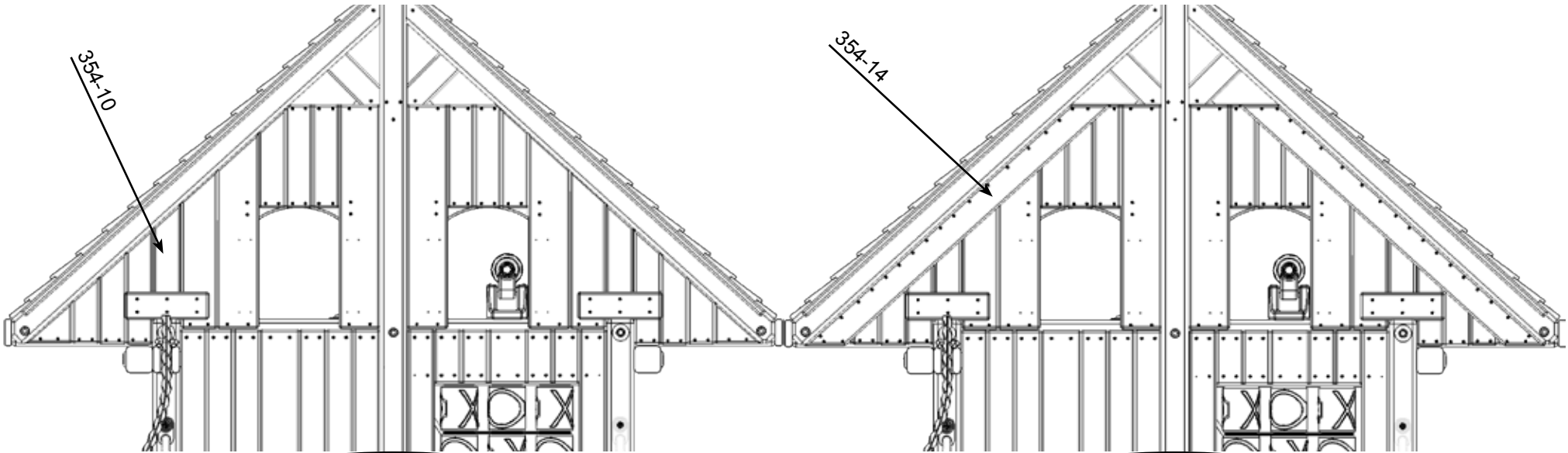

# Treehouse Panel Install (REPEAT FOR BOTH SIDES OF UNIT)

## PARTS NEEDED

- 354-6- 12" Left Window Shutter- (4)
- 354-5- 12" Right Window Shutter- (4)

## HARDWARE NEEDED

- TH-1- 1 1/2" Coated Deck Screw- (16)

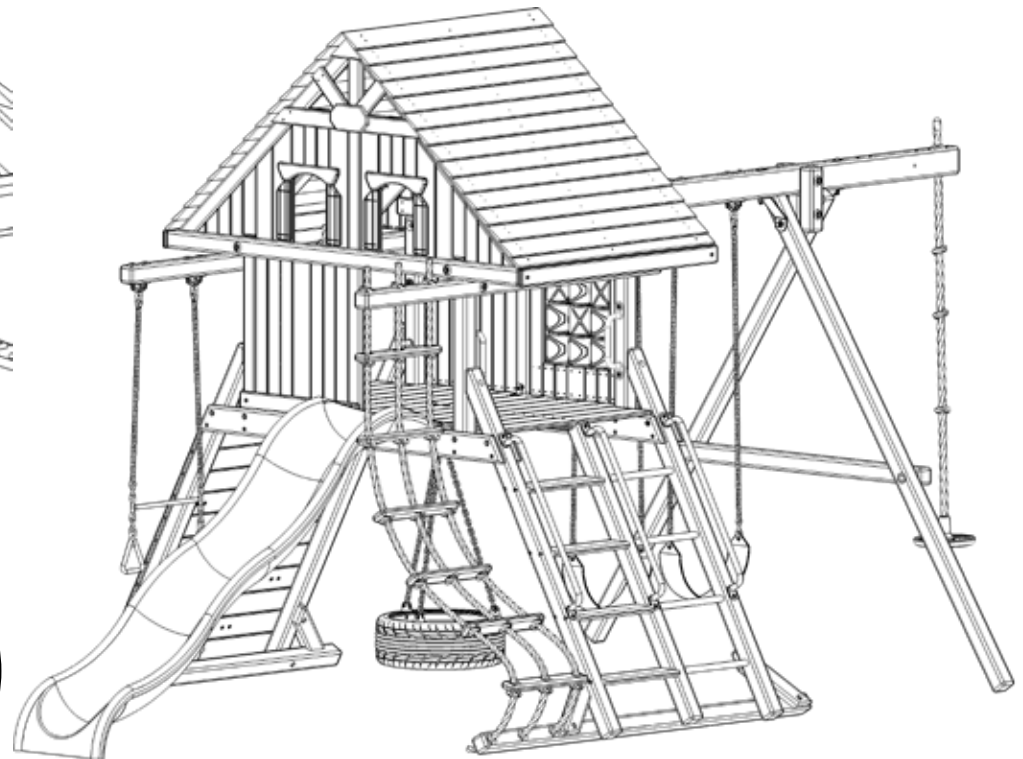
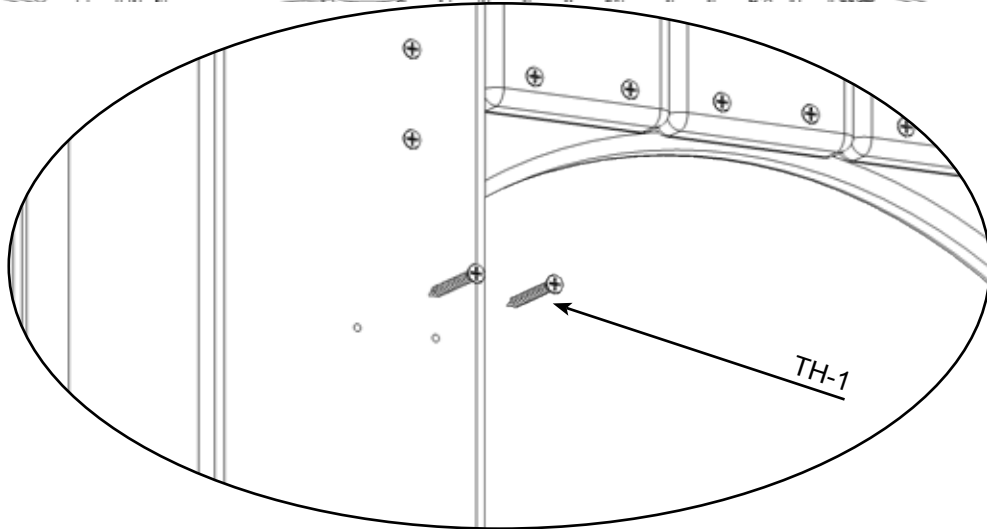
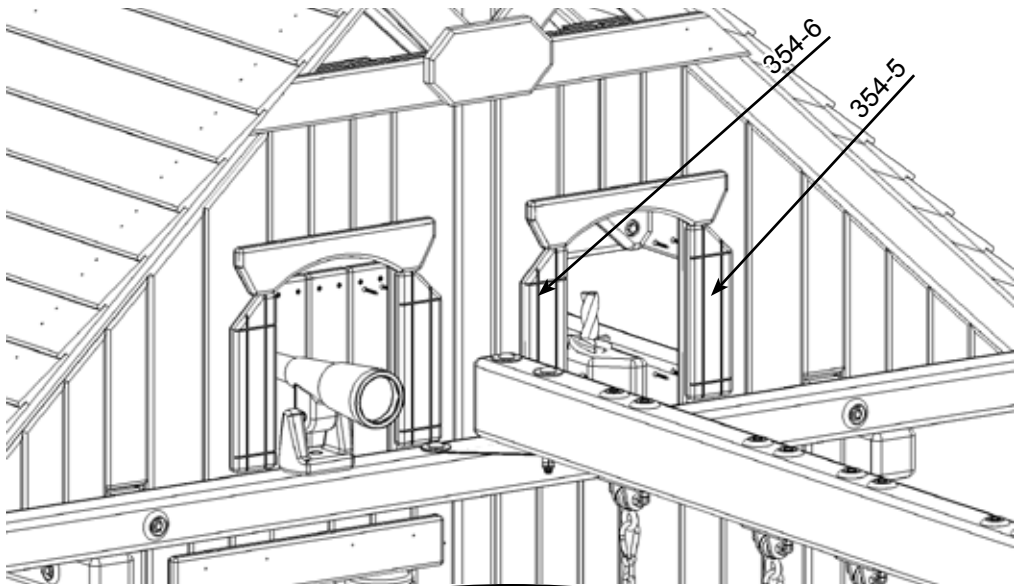

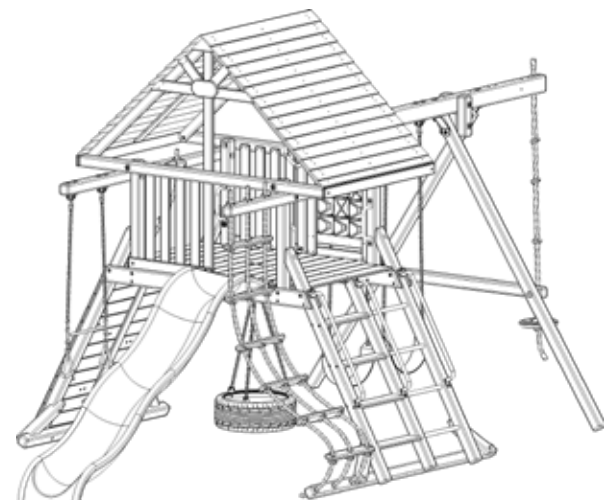
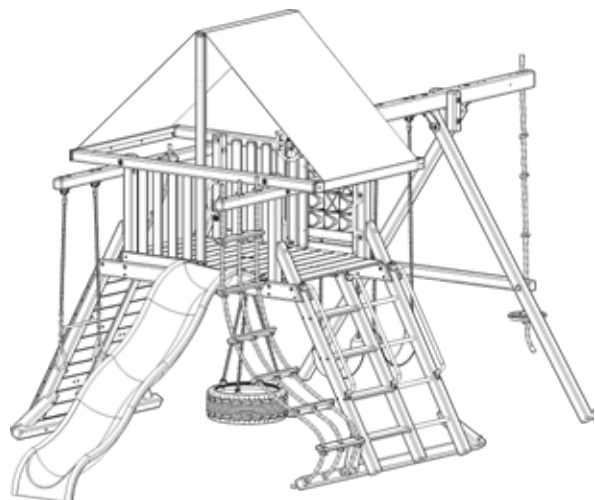

# PARROT ISLAND PLAYCENTER

