

6.5 BENGAL FORT

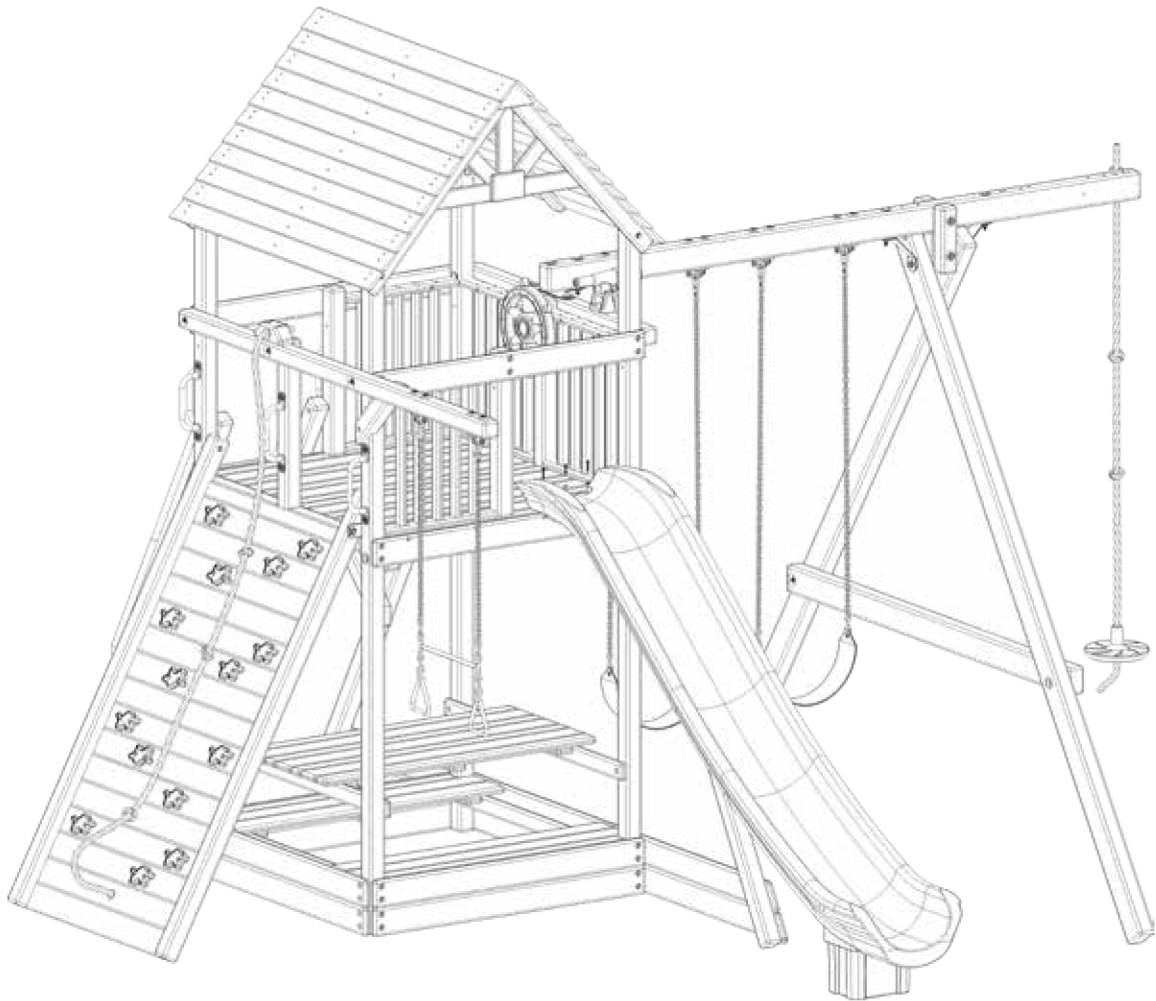

Version 1:20



4465 West Sam Houston Parkway N.
Houston, Texas 77041
WWW.TREEFROGSSHOWROOMS.COM

© 2018 KID STRUCTURES INC.

Sections

- Section 1: Cover & Liability Info
- Section 2: Product Parts
- Section 3: Sub-Assemblies
- Section 4: Main Assembly
- Section 5: Picnic/ Lower Floor
- Section 6: Rail Options
- Section 7: Playhouse Panel Install
- Section 8: Treehouse Install

IMPORTANT - PLEASE READ

As fresh lumber acclimates to its new environment, the natural tendencies of the tree can show itself in the form of checks, or “cracks” in the lumber. In almost all cases this is normal and it will not affect the structural integrity of your play set.

Cosmetic defects that do not affect the structural integrity of the product, or natural defects of wood such as warping, checking or any other physical properties of wood that do not present a safety hazard, are not covered by this warranty.

Defects that develop because the product is exposed to extreme climate conditions are not covered by this warranty. Defects that develop as a result of faulty or improper installation of the product are also not covered by this warranty.

Most cracks are not warrantable, however if you believe that the integrity of your play set is compromised by this natural occurrence, please contact the Tree Frogs Swing Set Dealer that you purchased your swing set from.

We appreciate your purchase and know that you will enjoy your play system for many years to come.

Tools Needed for Assembly

Tape Measure	24" Level	Angle Square
Phillips Screw Driver	3/8" Cordless Drill or Electric Drill	3/8" Drive Ratchet or Electric Impact Gun
Claw Hammer or Rubber Mallet	Pliers or Vise Grips	7/16" Deep Well Socket
9/16" Deep Well Socket	3/4" Deep Well Socket	1/8", 1/4", and 9/16" Drill Bits
Phillips Head Screw Bits	An Adult with two Adult Helpers	

Please familiarize yourself with the install manual, parts/components and general construction process of your new swing set before getting started. Approximate assembly time: 6 to 8 hours. 6 foot unobstructed safety perimeter around swingset recommended.

Pre-Assembly Hints

- Depending on your experience, assembly of our play sets can take as little as 6 hours up to 24 hours, depending on size, after inventory of parts; therefore, we recommend you set aside a full two days for assembly.
 - Identify all of the parts for your play set. Empty each box and lay out boards so you can see each part. Your instruction book will have detailed drawings that will make it easy for you to recognize individual parts. Keep all hardware and metal parts separate from wooden pieces.
 - After everything is laid out, check carefully to ensure all parts are present. Make sure there are no broken boards.
 - Find an area to sort your hardware. It is best to open the hardware on a solid surface so that you do not lose any pieces in the grass.
This will save time and familiarize you with all the different pieces in the hardware bag.
- **Important note: Wood has some natural defects such as knots, surface cracks, etc... We reject parts that are structurally defective. We use a high quality lumber in our structures; however, you should inspect each part for splinters or rough spots and sand them smooth to prevent injury.****
- After familiarizing yourself with all of the components, read all instructions thoroughly. Reading instructions after you have studied the parts will help you understand more clearly the installation process, and help to eliminate unnecessary mistakes.
 - Pay close attention to the diameter and length of each bolt and screw.
 - Never tighten hardware completely at first. It helps to have some adjustment for bolt alignment while you are attaching parts together. After everything is square, tighten each joint.
 - After the main unit is assembled it is critical that the floor is level and square. If the main frame is not level, the walls and floor will be out of square.
 - After you complete installation, make sure every bolt, screw, and nut is tight, and every board is secure. Wood will expand and contract with the seasons.
 - Place the set on level ground, not less than 6ft from any structure or obstruction such as a fence, garage, house, overhanging branches, laundry lines, or electrical wires.
 - All 1/4" and 3/8" lag bolts must have pre-drilled holes 1-1/2" to 2" deep. Use a 1/8" drill bit for the 1/4" lag bolts and 1/4" drill bit for 3/8" lag bolts. Use pre-drilled holes in facias as a reference for placing lag bolt pilot holes.
 - If a board lifts or rises causing a gap between boards when running in lag bolts or screws, back out the screw or lag bolt and press or apply pressure (but not enough to crack or break board) while re-running in the lag bolt or screw in the same hole.
 - Do not over tighten bolts, lag bolts or screws. You can damage boards, break hardware, and/or strip out the hardware.
 - When using hammer do not beat on the hardware, but gently tap it in. Never beat on the wood as it will leave marks.

Leveling Your Swing Set During Assembly

- Complete the steps which will be the basic frame of the fort {i.e. four corner posts with base (sand box boards) and deck supports}
- Position in the most level area chosen for the play set, keeping in mind the location and size of the swing beam, ladder, slides, etc. that extend off the fort.
- Once the frame is in the final position, check for vertical and horizontal levelness to determine which side(s) will need to be dug into the ground to level the play set.
- With a shovel, score the ground around the outside edges of the sandbox boards on the 'high' side of the fort. This is the area that will be dug in. Make sure to score deep enough; the scored lines will be your digging template.
- Push the frame off and away from the scored area, far enough to dig and remove dirt to reach the appropriate depth.
- Dig a channel along the scored line(s) for the base of the fort (corner post and sandbox boards) to rest into. Dig the channel(s) to the same level depth. The bottom of the channel(s) should be level to each other so your frame doesn't teeter or rock because the channel(s) are uneven.
- Once you have removed enough grass and dirt, slide/push the frame into the channel(s). Place a level on the vertical and horizontal boards of the frame to determine if enough soil, or too much, was removed.
- Repeat this process until the basic frame is plumb and level and in its final position before completing the rest of the assembly.
- Measure to make sure fort is square.

**** Important: if you require a channel depth of more than 6", then we recommend you have your play set area professionally graded before completing assembly. ****

Choosing A Location For Your Playset

When choosing a location for your swing set, always keep your child or children's safety in mind. Here are some recommendations to help you locate and install a safe play area.

- This play set is designed for the use of 4 occupants who have a combined weight not exceeding 800 pounds on the elevated floor; 3 occupants who have a combined weight of 525 pounds on the swing area; for a total Unit capacity of 5 occupants who have a combined weight of 1325. (this weight is not including the picnic table area)
- On-site adult supervision is required.
- The swing set should be located on level ground. The stationary components such as ladders and slides are required to be a minimum of six feet from any structure or obstruction such as a fence, garage, house, tree, overhanging branches, electrical wires, clotheslines, etc. Any swinging equipment is also required to be a minimum distance twice the height of the swing beam away from these obstructions or structures as well. The swing set should be located a safe distance from any water hazards, such as a lake, river, bayou, swimming pool, etc.
- Do not install this residential swing set in a commercial setting. This swing set is not manufactured for commercial usage and will void all warranties. Tree Frogs Wooden Swing Set Factory is not responsible for any damages or injuries resulting from this swing set being used in a commercial setting.
- Never install this swing set indoors; or over concrete, asphalt, packed earth, grass, carpet or any other hard surface. A fall onto a hard surface can result in serious or fatal injury.
- The U.S. Consumer Product Safety Commission (CPSC) recommends that you install and maintain a resilient surface under your swing set. The CPSC's Consumer Information Sheet for Playground Surfacing Materials is on the next page. A resilient surface, should be installed after the swing set has been completely assembled according to these instructions. The swing set must rest on solid ground. Please note that this swing set has a maximum fall height of 7'.

Maintaining Your Swing Set

Here are some maintenance tips required to insure safe play on your swing set for years of fun.

- At the beginning of each usage season and every two weeks during, check: nuts and bolts and tighten as needed, swing seats, chains, ladders, slides, rope and wood components for sign of deterioration and replace if necessary.
- On a yearly basis, we recommend that you coat your swing set with a sealant or preservative. You may also want to spot sand any areas prior to sealing.

**** Special note: Although we recommend that you reseal your swing set annually, you may have to touch up the high traffic areas and/or areas that have a high exposure to direct sunlight.****

- Be sure that the sealant you select is non-toxic and child safe. Your local Tree Frogs Wooden Swing Set Factory dealer may offer a complete power wash and reseal and maintenance program.
- Do not use line trimmers or "weed eaters" around your swing set. The line will remove both paint and wood from uprights and base pieces. Any damage resulting from this type of abuse is not covered under our limited warranty.
- Remove plastic swing seats and take in doors or do not use when temperature drops below 0°F.

Please keep this install manual for future reference.

To insure SAFE PLAY adults must teach children:

- Not to walk close to, in front of, behind, or between moving items.
- Not to swing empty swing seats.
- Not to swing sideways into the path of adjacent swings.
- Not to use the swing set in a manner other than that for which it is intended.
- Not to get off the equipment while it is in motion.
- Not to jump off the tower.
- Not to stand in the swing seats.
- Not to swing so high that chains become slack, or above the height of the swing support.
- Not to jump on a slide.
- Not to climb on top of the swing support.
- Not to attach to the swing set any item that is not specifically designed for use with the equipment, such as (but not limited to) jump ropes, clotheslines, pet leashes, cables, and chains. These may become strangulation hazards.
- To hold on to swings and climbers with both hands.
- To slide feet first, never head first.
- To watch for other children while swinging or playing near the swing set.

To also insure SAFE PLAY adults must:

- Limit climbing and swinging heights to each child's ability.
- Verify that suspended climbing ropes are secured at both ends.
- Verify that suspended climbing ropes cannot be looped back on themselves.
- Dress children appropriately for play. Use well-fitted shoes that do not have slippery soles.
- Avoid ponchos, scarves, hoods, loose fitting clothing, neckties, and any clothing with a drawstring. Serious injury could result should any part of the children's clothing become entangled in the swing set.
- Do not allow children to play wearing helmets.
- Remember that children are inventive. When they develop games that are unsafe, be alert and change the rules.

Weight limits for Treefrogs Swingsets

Fort Platform: 800 Lbs.Total Weight.

Swing Belts: 175 Lbs.

Trapeze: 125 Lbs.

Full Bucket Swing: 50 Lbs.

Toddler Bucket Swing: 50 Lbs.

Tire Swing: 125 Lbs. Total Weight

Rope Ladder: 75 Lbs.

Rock Wall: 150 Lbs.

All Slides: 125 Lbs.

Tree Frogs recommends that the weight limits for all components must not be exceeded. Failure to adhere to these and other safety guidelines could result in damage to the swing set. and/or injury to the users.

CONSUMER INFORMATION SHEET FOR PLAYGROUND SURFACING MATERIALS

The U.S. Consumer Product Safety Commission (CPSC) estimates that about 100,000 playground equipment related injuries resulting from falls to the ground surface are treated annually in U.S. hospital emergency rooms. Injuries involving this hazard pattern tend to be among the most serious of all playground injuries, and have the potential to be fatal, particularly when the injury is to the head. The surface under and around playground equipment can be a major factor in determining the injury-causing potential of a fall. It is self-evident that a fall onto a shock-absorbing surface is less likely to cause a serious injury than a fall onto a hard surface. However, it should be recognized that some injuries from falls will occur no matter what playground surfacing material is used.

Playground equipment should never be placed on hard surfaces such as concrete or asphalt. Grass may appear to be acceptable, but can turn to hard packed earth in areas of high traffic. Shredded bark mulch, wood chips, or fine gravel are considered to be acceptable shock absorbing surfaces when installed and maintained at a sufficient depth under and around play equipment.

TABLE 1 -CRITICAL HEIGHTS (in feet) OF TESTED MATERIAL

MATERIAL	UNCOMPRESSED DEPTH			COMPRESSED DEPTH
	6 Inch	9 Inch	12 Inch	9 inch
Wood Chips	7	10	11	10
Double Shredded Bark Mulch	6	10	11	7
Engineered Wood Fibers	6	7	>12	6
Fine Sand	5	5	9	5
Coarse Sand	5	5	6	4
Fine Gravel	6	7	10	6
Medium Gravel	5	5	6	5
Shredded Tires**	10-12	N/A	N/A	N/A

** This is data from tests conducted by independent testing laboratories on a 6 inch depth of uncompressed shredded tire samples produced by four manufacturers. The test reported critical heights, which varied from 10 feet to greater than 12 feet. It is recommended that persons seeking to install shredded tires as a protective surface request test data from the supplier showing the critical height of the material when it was tested in accordance with ASTM F1292.

Table 1 should be read as follows: If, for example, uncompressed wood chips are used at a minimum of 6 inches, the Critical Height is 7 feet. If 9 inches of uncompressed wood chips are used, the Critical Height is 10 feet. It should be noted that, for some materials, the Critical Height decreases when the material is compressed. It is recommended that a shock absorbing material should extend a minimum of 6 feet in all directions from the perimeter of stationary equipment such as climbers and slides. However, because children may deliberately jump from a moving swing, the shock absorbing material should extend in the front and rear of a swing a minimum distance of 2 times the height of the pivot point measured from a point directly beneath the pivot on the supporting structure.

This information is intended to assist in comparing the relative shock-absorbing properties of various materials. No particular material is recommended over another. However, each material is only effective when properly maintained. Materials should be checked periodically and replenished to maintain correct depth as determined necessary for your equipment. The choice of a material depends on the type and height of the playground equipment, the availability in your area, and its cost.

This information has been extracted from the CPSC publications "Playground Surfacing-Technical Information Guide" and "Handbook for Public Playground Safety." Copies of these reports can be obtained by sending a postcard to:

Office of Public Affairs
U.S. Consumer Product Safety Commission
Washington, D.C. 20207

Toll-free Hotline: 1-800-638-2772 or at <http://www.cpsc.gov>

2018 TREE FROGS Limited Lifetime Warranty

Limited 10-Year Warranty, Limited 5-Year Warranty

Tree Frogs Warranties all Jaguar Playcenter Series, Bengal Forts Series, MegaDeck Fort Series Redwood components and Cedar components against structural failure due to warping, wood rot, insect infestation (excluding Carpenter Bees) or decay for the period of 10 Years from the date of original purchase. This warranty does not cover cracks, fissions, checks, fading, knots and weathering that are normal natural characteristics of wood, that do not affect the structural integrity of the product. The Redwood and Cedar components warranty is extended to a Limited Lifetime Warranty to the original owner upon registering this warranty within 90 days of purchase at www.treefrogsswingsets.com.

Tree Frogs Warranties all Parrot Island Fort Series, Parrot Island Playcenter Series, Rainforest Cottage Series Cedar components against structural failure due to warping, wood rot, insect infestation (excluding Carpenter Bees) or decay for a period of 10 Years from the date of original purchase. This warranty does not cover cracks, fissions, checks, fading, knots and weathering that are normal natural characteristics of wood, that do not affect the structural integrity of the product.

Tree Frogs Warranties all Toucan Fort Series, Toucan Playcenter Series, Orangutan Fort Series, Stand Alone Swings Cedar components against structural failure due to warping, wood rot, insect infestation (excluding Carpenter Bees) or decay for a period of 5 Years from the date of original purchase. This warranty does not cover cracks, fissions, checks, fading, knots and weathering that are normal natural characteristics of wood, that do not affect the structural integrity of the product.

In addition, a 10-Year Limited Warranty applies to all roto-molded slides, ductile iron swing hangers, tire swivels, metal climbing rungs and swing beam brackets against failure due to rust or failure in defect in material. Surface rust, fading, weathering, cracks/chips in coatings and corrosion that do not affect structural integrity are not covered by this warranty. Furthermore, a 5-Year Limited Warranty applies to all components & accessories including all swings, chain ladders, gliders, handles, brackets, bubble panels, tarps, steering/ships wheels, telescopes, binoculars, buoy ball, blow molded slides and disc seat that are not covered under the 10-Year Warranty to be free from defects in material and workmanship. Surface rust, fading, weathering, cracks/chips in coatings and corrosion that do not affect structural integrity are not covered by this warranty.

And for a period of 1-Year Tree Frogs warranties all ropes, structural foam molded slides to be free of defects in material and workmanship. Fading is not considered a defect and may occur with seasonal and geographical conditions.

****10-Year Warranty Exclusion: Toucan Fort Series, Toucan Playcenter Series, Orangutan Series, Stand Alone Swings (Limite 5Yr/5Yr/1Yr WARRANTY).**

This warranty is limited to a repair or replacement of the defective part. Product covered under this warranty will be shipped at the customer's expense. Tree Frogs is not responsible for any expense associated with freight, or delivery and installation of the warranted part(s). Tree Frogs reserves the right to inspect all warranty claim parts for which a claim has been made.

This limited warranty applies only to the original retail purchaser and for residential use only, non-residential use voids warranty. These warranties void when product is transferred or sold or no longer in possession by original owner. A copy of the original invoice must be presented to initiate warranty claim. This limited warranty does not cover damage from abuse, acts of God, vandalism, maintenance guideline neglect, alterations, normal wear & tear, use other than residential, unauthorized modification, damage due to moving of product or improper installation and or use. Any modification could damage the structural integrity of the play system and voids all warranties.

This warranty is exclusive and expressly in lieu of all other warranties, expressed or implied, including warranties of merchantability or fitness for use. Tree Frogs does not assume, or authorize any person to assume for us, any other liability in connection with the sale of our products.

This warranty gives you specific legal rights, and you also may have other rights that vary from state to state. Register your play system's warranty at www.treefrogsswingsets.com.

Tree Frogs reserves the right at any time to change product specifications or substitute similar components.

See your instruction manual for guidelines on regular maintenance. <http://treefrogsshowrooms.com/installation-manuals/>. Your child's play system & perimeter play zone should be inspected regularly for any wear & safety hazards.

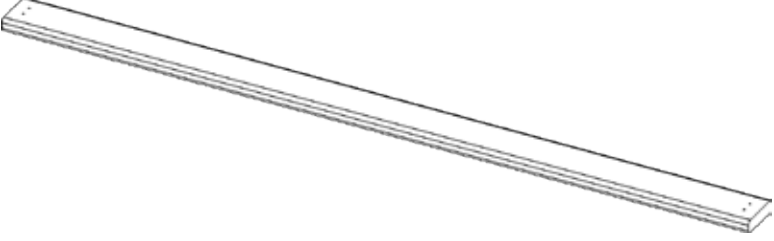
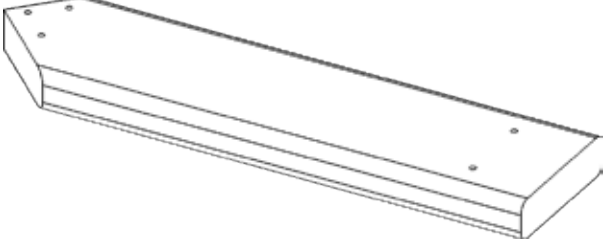
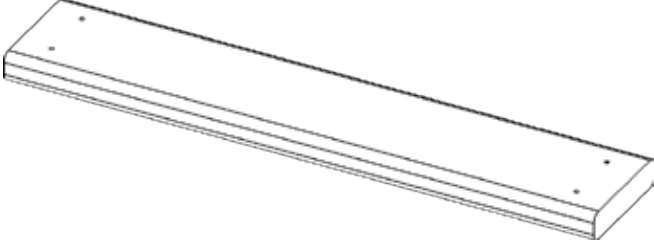
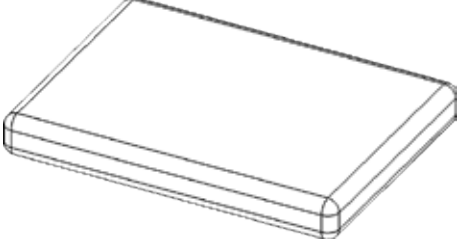
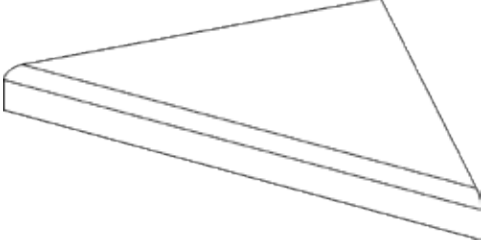
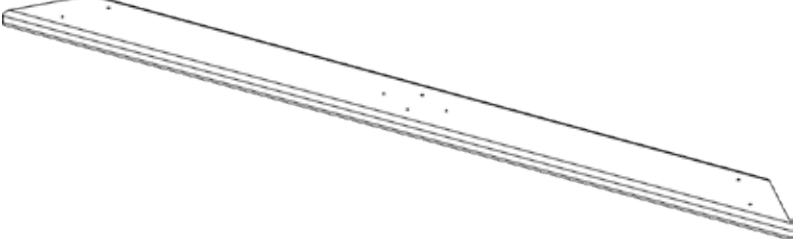
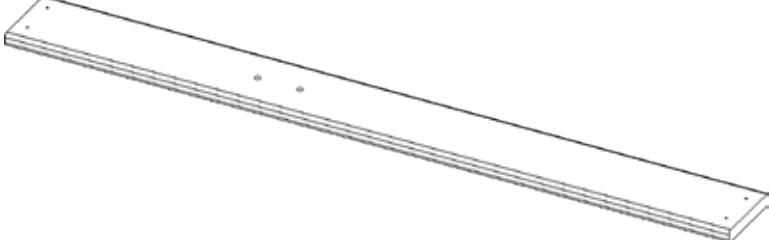
KSI-405 6.5 Jaguar Fort Lumber	Description	QTY.
	<p>405-1 50 1/8" Small Blank Rockwall Board</p>	<p>1</p>
	<p>(CC-003) 405-2 12 1/8" Long Fan Board</p>	<p>4</p>
	<p>(CC-015) 405-3 18" Center Fan Board</p>	<p>2</p>
	<p>(CC-051) 405-4 7 3/16" Center Fan Cap</p>	<p>2</p>
	<p>(CC-053) 405-5 9 9/16" Wood Roof Peak</p>	<p>2</p>
	<p>(CC-041) 405-6 42 1/2" Bottom Fan Board</p>	<p>2</p>
	<p>(CC-84) 405-7 50 1/8" 1-Rock Rockwall Board</p>	<p>7</p>

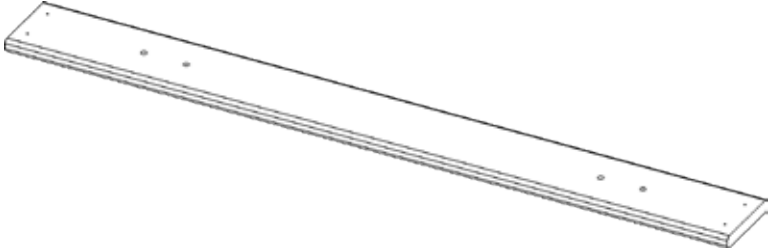
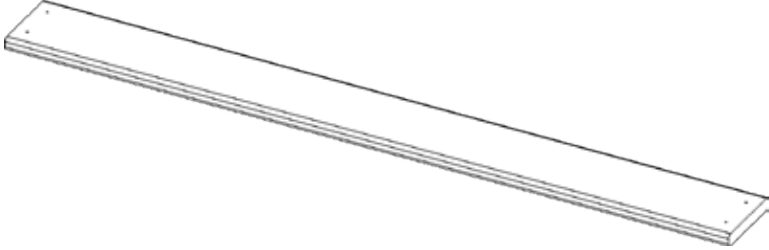
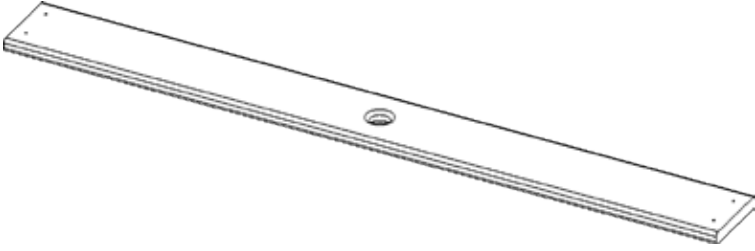
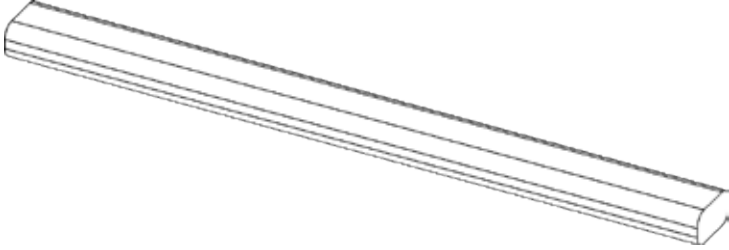
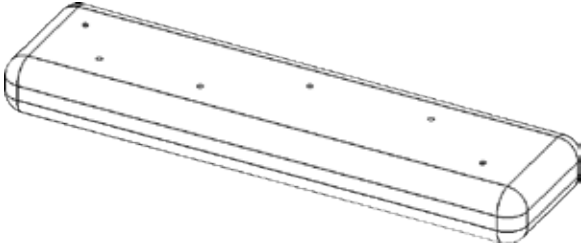
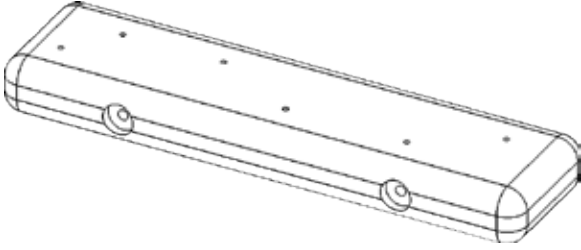
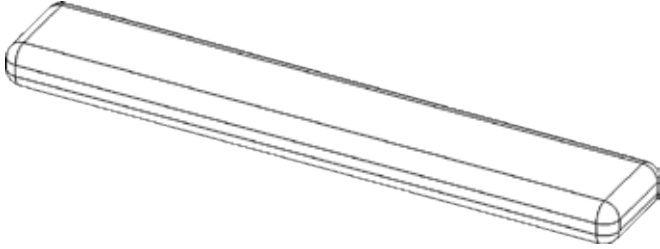
KSI-405 6.5 Jaguar Fort Lumber	Description	QTY.
	(CC-085) 405-8 50 1/8" 2- Rock Rockwall Board	4
	(CC-086) 405-9 50 1/8" Blank Rockwall Board	4
	(CC-087) 405-10 50 1/8" Rope Hole Rockwall Board	1
	(CC-088) 405-11 27 1/2" Rail Spindle	20
	(CC-091) 405-12 12 7/8" Center Picnic Support	2
	(CC-092) 405-13 12 7/8" Picnic Side Support	4
	(CC-098) 405-14 20" Wood Roof Support	2

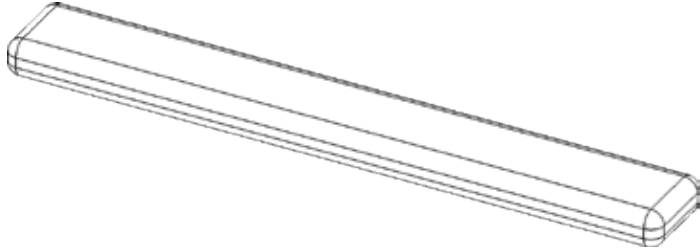
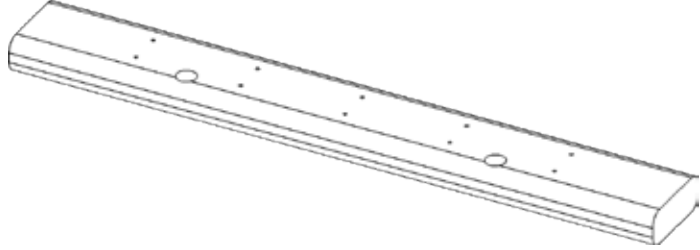
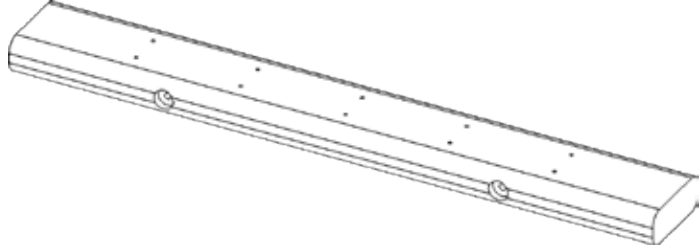
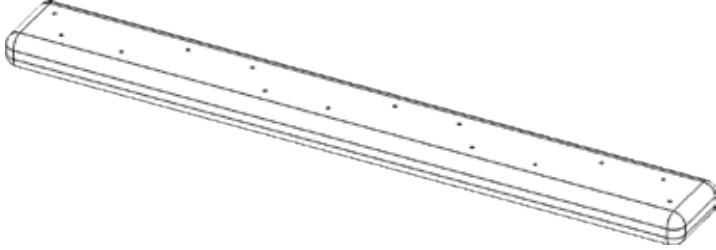
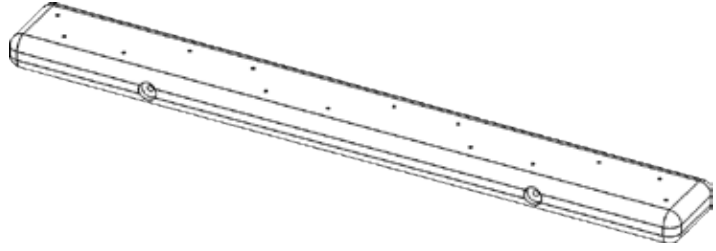
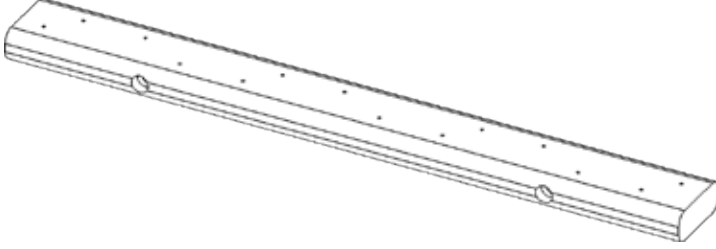
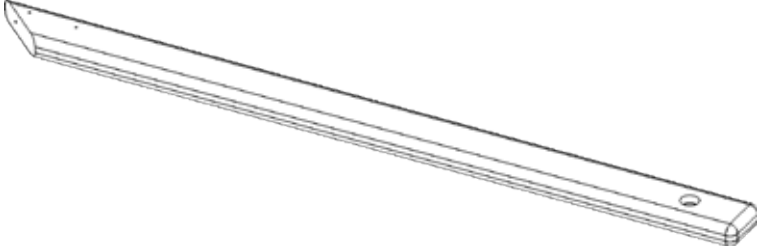
KSI-405 6.5 Jaguar Fort Lumber	Description	QTY.
	(CC-097) 405-15 24 1/2" Wood Roof Support	2
	(CC-100) 405-16 25" Rail Bottom	6
	(CC-099) 405-17 25" Rail Top	4
	(CC-105) 405-18 28 1/4" Picnic Center Support	1
	(CC-106) 405-19 28 1/4" Picnic Side Support	2
	(CC-104) 405-20 30" Deck Runner	4
	(CC-107) 405-21 48 1/8" Wood Roof Support	4

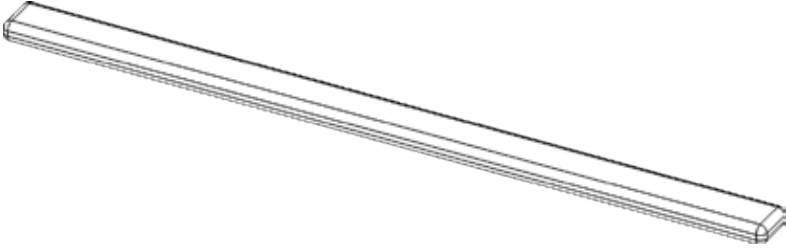
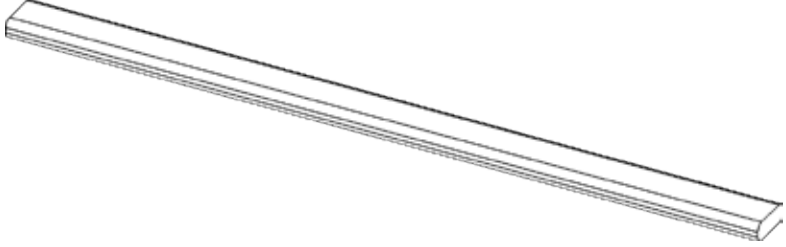
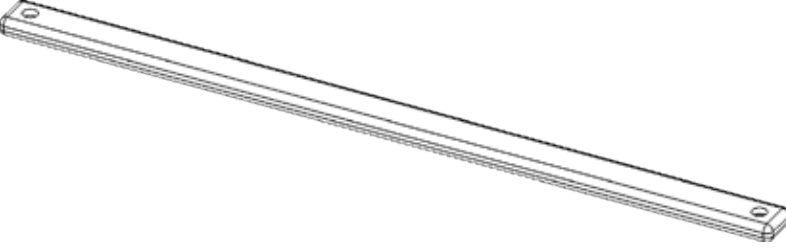
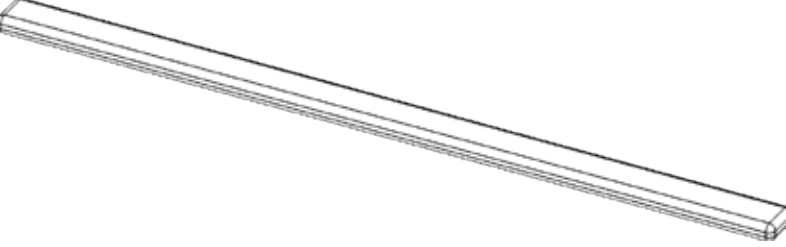
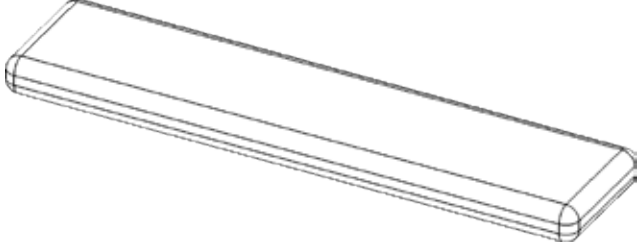
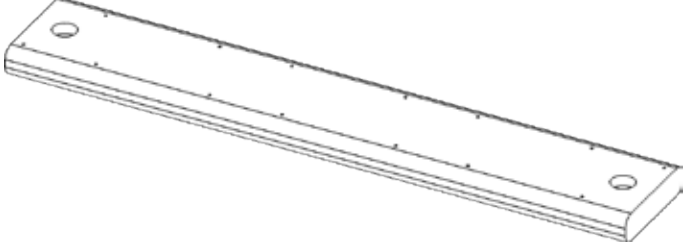
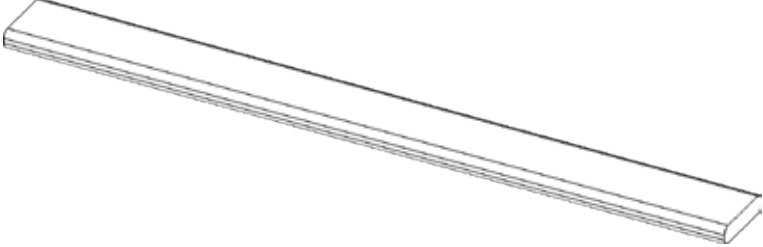
KSI-405 6.5 Jaguar Fort Lumber	Description	QTY.
	(CC-113) 405-22 54" Picnic Table Board	4
	(CC-114) 405-23 54" Deck Board	8
	(CC-115) 405-24 60 1/4" Picnic Support	4
	(CC-117) 405-25 60 3/4" Picnic Table Board	7
	(CC-123) 405-26 21 9/16" Step	7
	(CC-122) 405-27 30" Center Deck Support	2
	(CC-124) 405-28 54" Deck Board	6

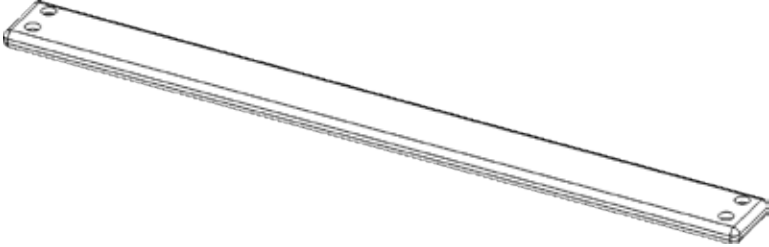
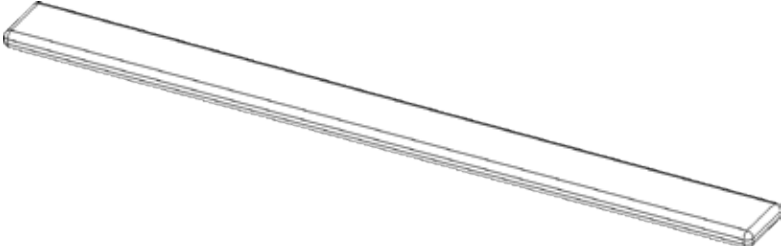
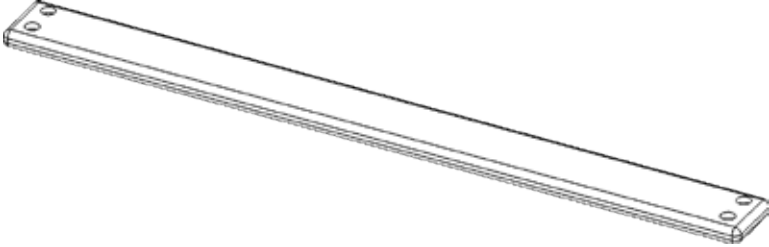
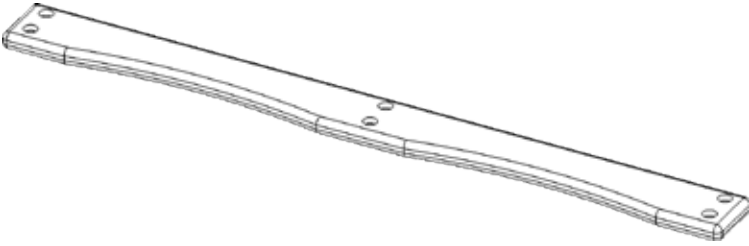
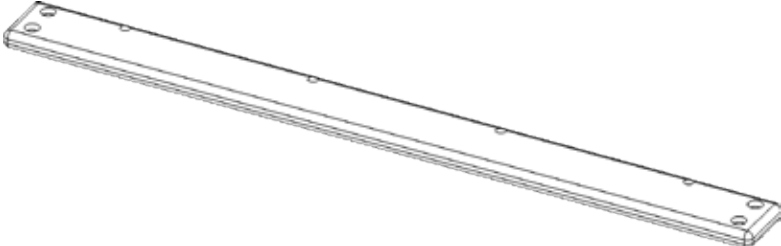
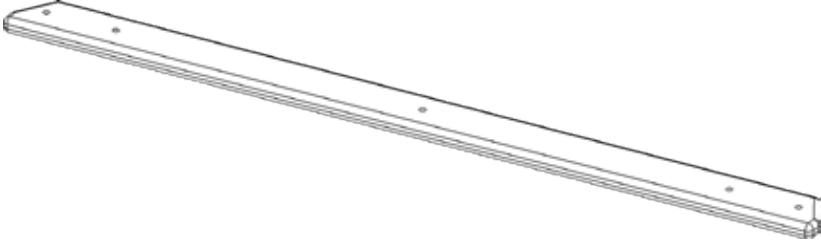
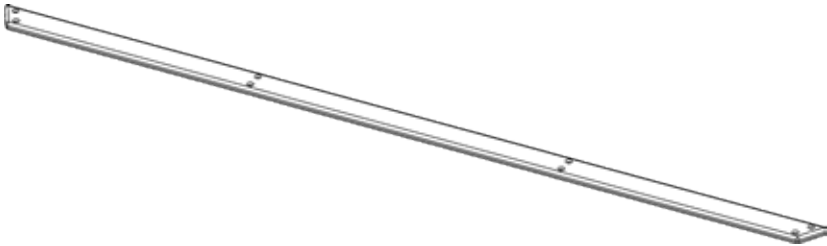

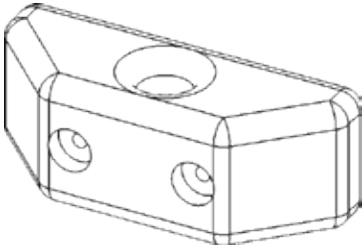
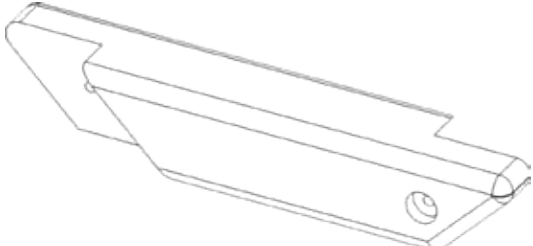
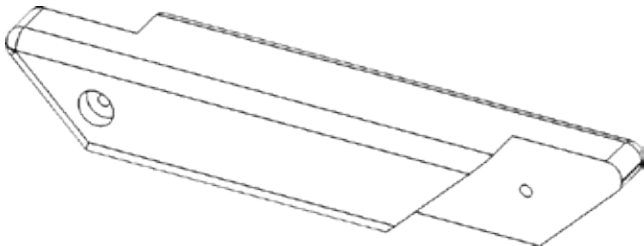
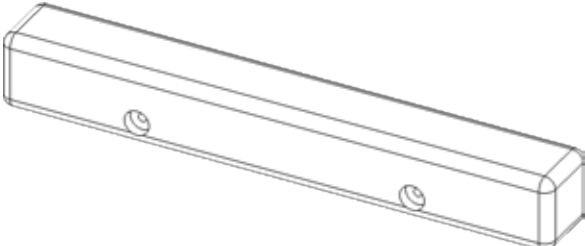
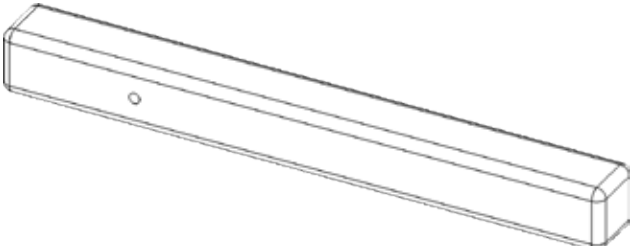
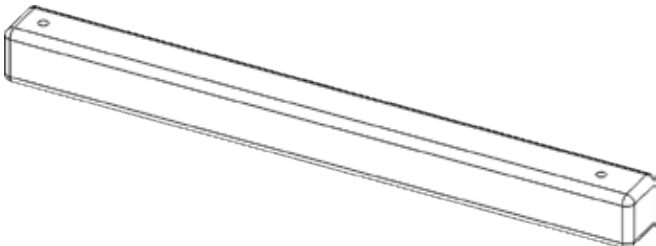
KSI-405 6.5 Jaguar Fort Lumber	Description	QTY.
	(CC-125) 405-29 60 1/4" 4- Hole Facia	4
	(CC-126) 405-30 60 3/4" Picnic Table Board	7
	(CC-127) 405-31 60 3/4" 4- Hole Facia	3
	(CC-128) 405-32 60 3/4" 6- Hole Facia	2
	(CC-129) 405-33 60 3/4" 8- Hole Facia	2
	405-34 75" Support Wing Mainbeam	1
	405-35 150 3/4" Short Wing Runner	1

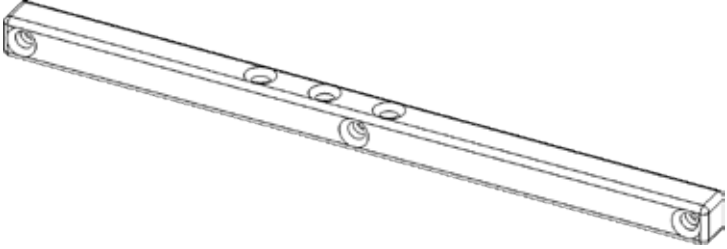
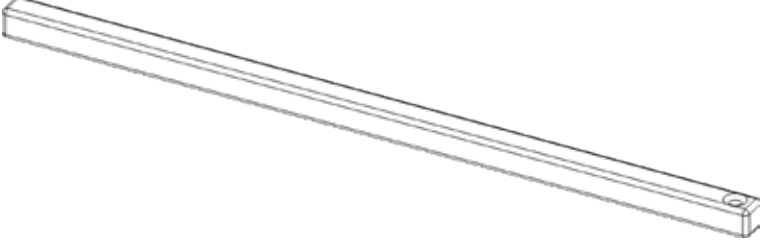
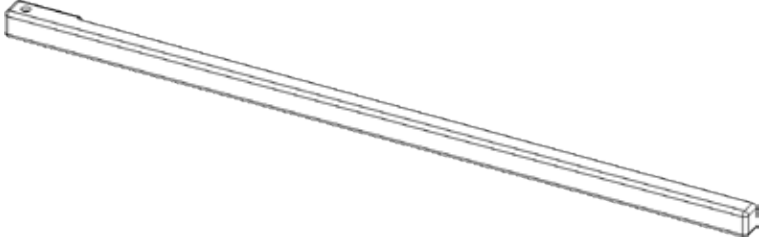
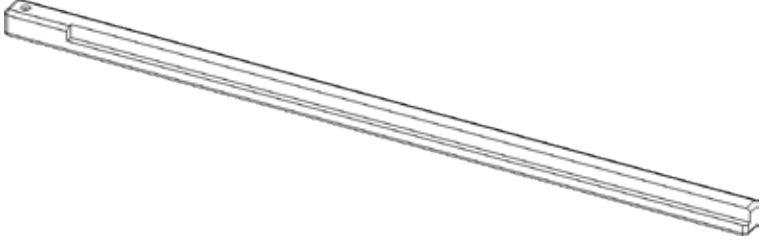
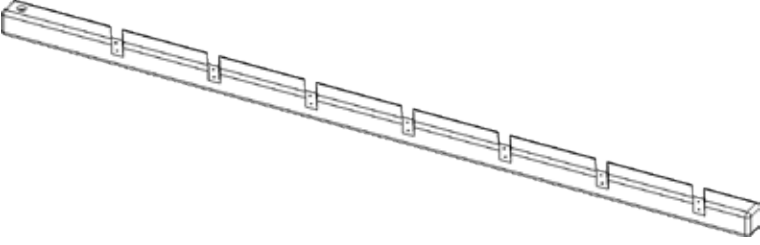
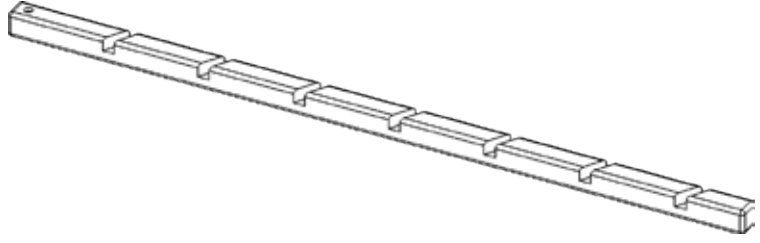
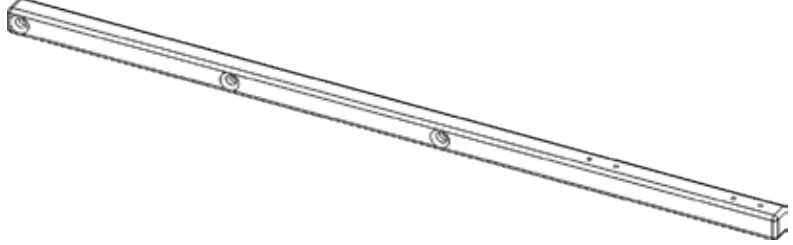
KSI-405 6.5 Jaguar Fort Lumber	Description	QTY.
	<p>405-36 155 7/8" Long Wing Runner</p>	<p>1</p>
	<p>(CC-143) 405-37 9" Rope Block</p>	<p>1</p>
	<p>(CC-148) 405-38 19" Right Gusset</p>	<p>3</p>
	<p>(CC-149) 405-39 19" Left Gusset</p>	<p>2</p>
	<p>(CC-142) 405-40 25" Entrapment Block</p>	<p>1</p>
	<p>(CC-164) 405-41 32 1/8" Center Post</p>	<p>2</p>
	<p>(CC-165) 405-42 38 7/8" Center Upright</p>	<p>2</p>

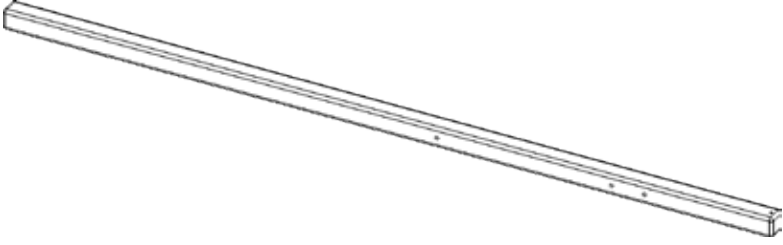
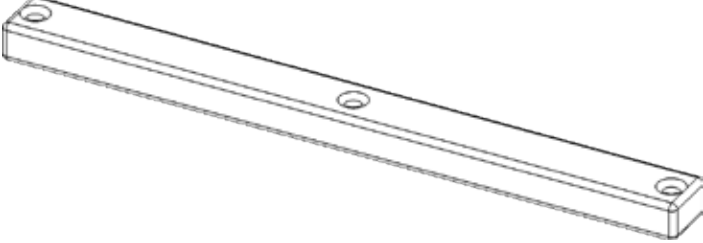
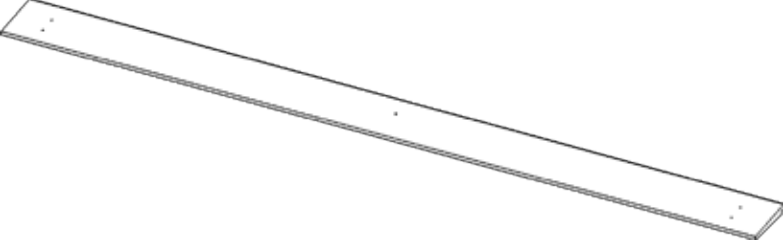
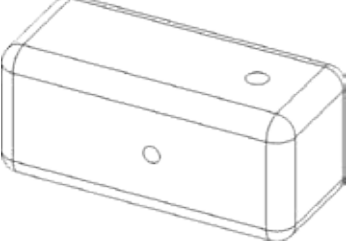
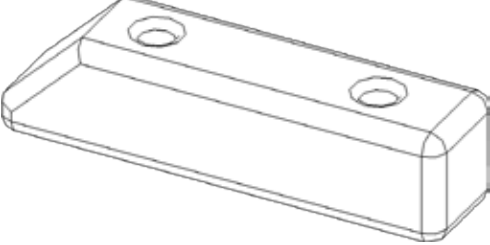
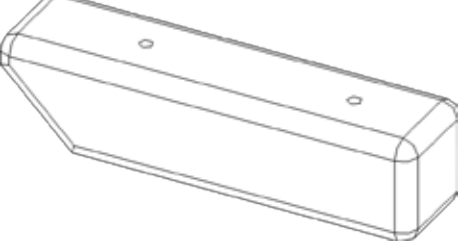
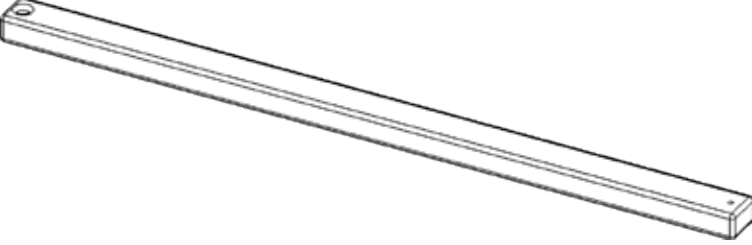

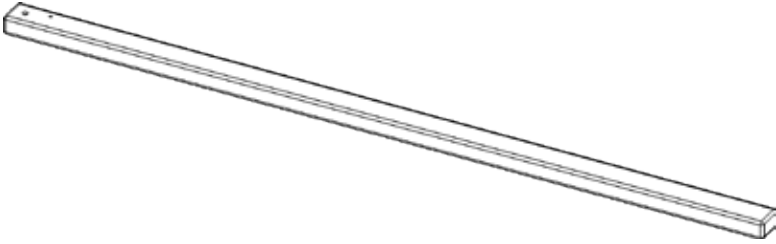
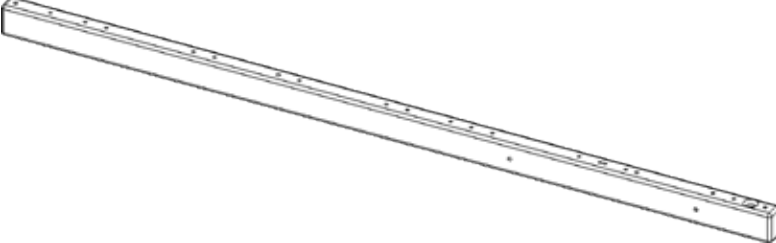
KSI-405 6.5 Jaguar Fort Lumber	Description	QTY.
	(CC-160) 405-43 60 1/4" SB Top Joist	1
	405-44 85 15/16" Wing Support Leg	2
	405-45 95 3/16" Left Rockwall Leg	1
	405-46 95 3/16" Right Rockwall Leg	1
	405-47 101" Left Ladder Leg	1
	405-48 101" Right Ladder Leg	1
	(CC-166) 405-49 104" Trapeze Arm	1

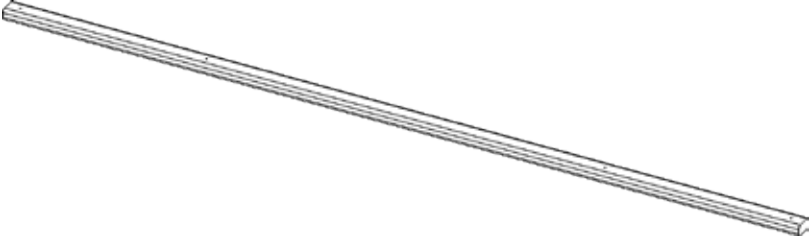
KSI-405 6.5 Jaguar Fort Lumber	Description	QTY.
	<p>405-50 128" Corner Post</p>	<p>4</p>
	<p>(CC-187) 405-51 60 1/4" Mainbeam</p>	<p>2</p>
	<p>(CC-195) 405-52 67 1/2" Wood Roof Board</p>	<p>22</p>
	<p>(CC-240) 405-53 7 7/8" Center A-Frame Block</p>	<p>1</p>
	<p>(CC-244) 405-54 13 3/8" A-Frame Block Sunked</p>	<p>1</p>
	<p>(CC-243) 405-55 13 3/8" A-Frame Block</p>	<p>1</p>
	<p>(CC-245) 405-56 88" A-Frame Crossmember</p>	<p>1</p>

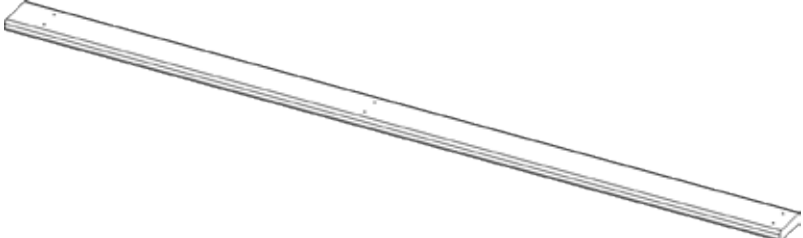
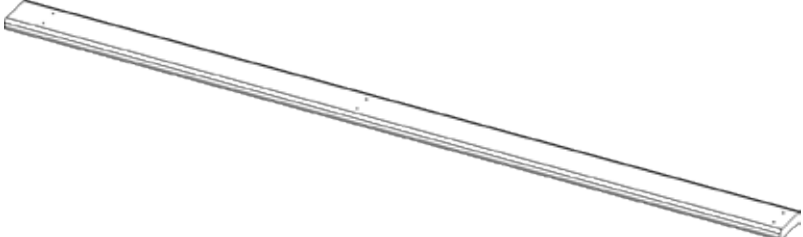
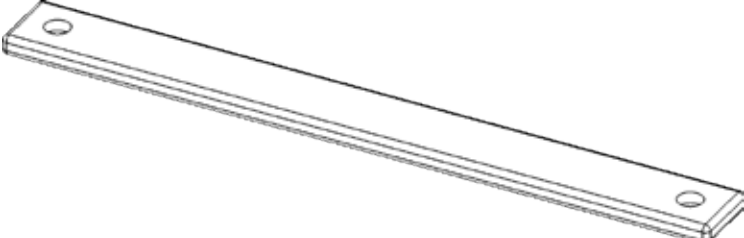
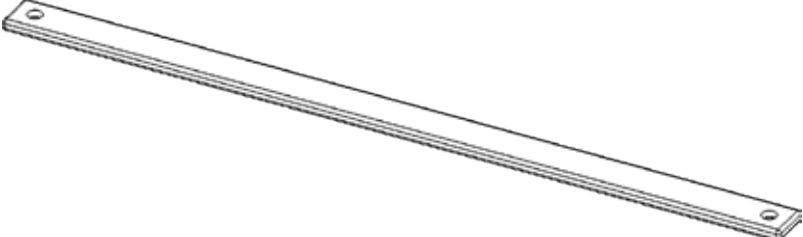
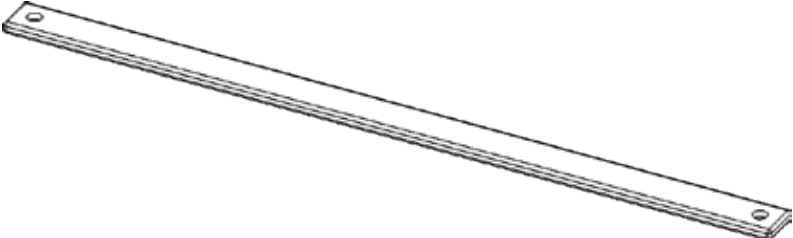
KSI-405 6.5 Jaguar Fort Lumber	Description	QTY.
	(CC-246) 405-57 143" A-Frame Leg	2
	(CC-184) 405-58 132 5/8" Jaguar Universal Swingbeam	1

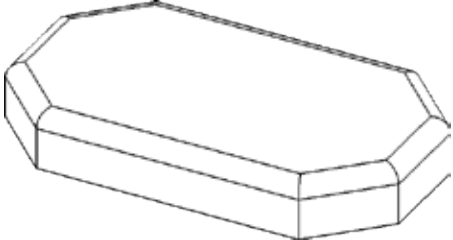
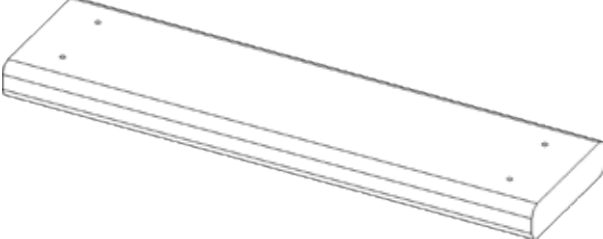
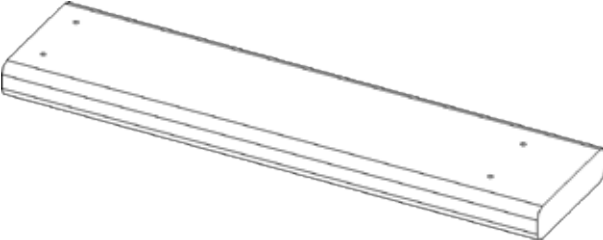
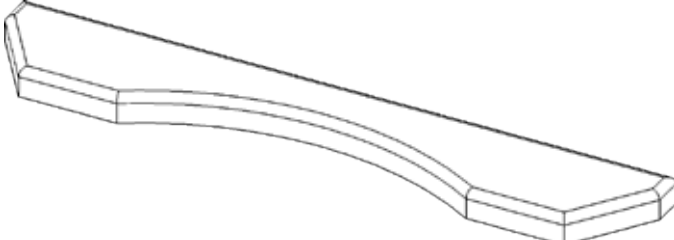
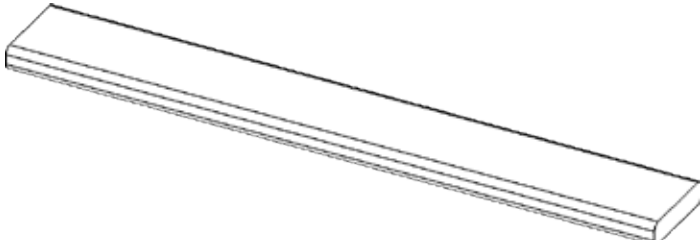
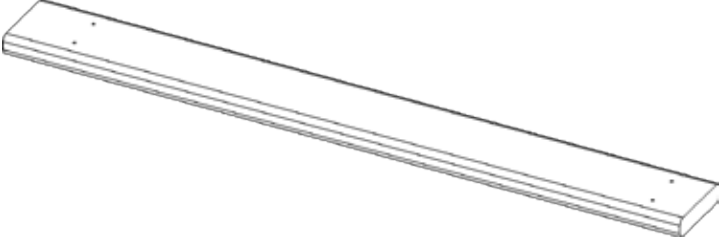
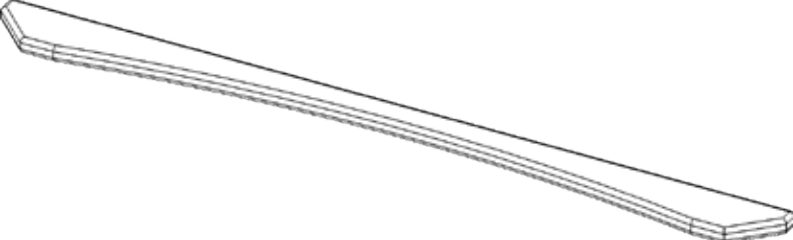

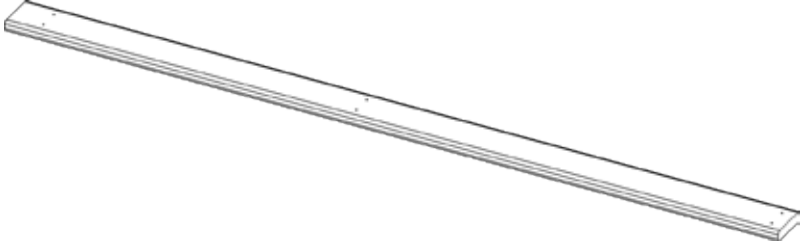
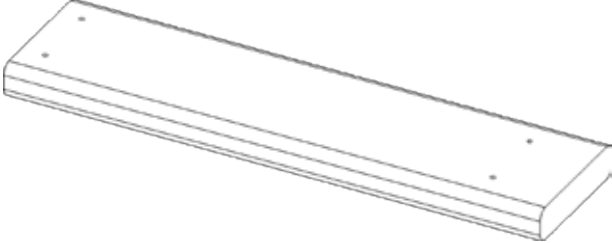
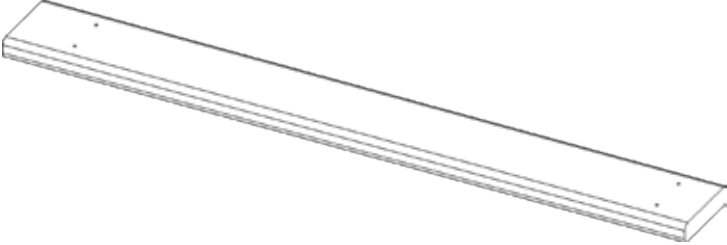
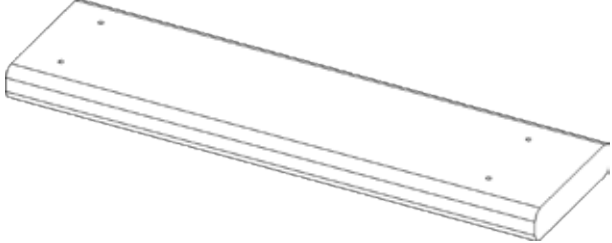
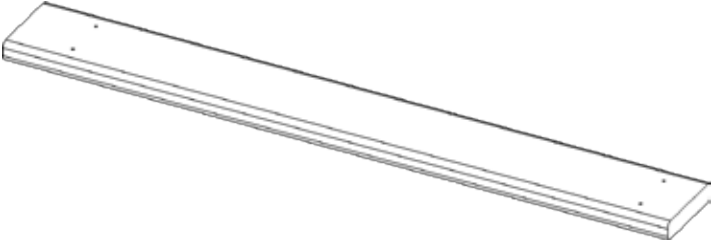
KSI-408 Playhouse Panel Lumber	Description	QTY.
	<p>408-1 63 1/16" Door Stop</p>	<p>1</p>
	<p>408-2 63 11/16" Slim Door Board</p>	<p>2</p>
	<p>408-3 62 3/4" Center Wing Side Board</p>	<p>1</p>
	<p>408-4 64 1/8" Center Playhouse Panel Board</p>	<p>1</p>
	<p>(CC-027) 408-5 32 1/8" Door Side Cross Facia</p>	<p>2</p>
	<p>(CC-037) 408-6 60 1/4" Side Cross Facia</p>	<p>4</p>
	<p>(CC-040) 60 3/4" Store Cross Facia</p>	<p>2</p>

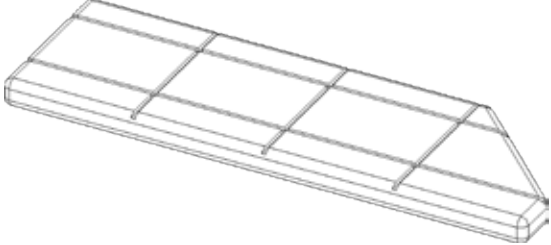
KSI-408 Playhouse Panel Lumber	Description	QTY.
	(CC-005) 408-8 6" Door Knob Plate	1
	408-9 12 7/8" Upper Floor Filler	11
	408-10 14" Above Window Filler	14
	(CC-016) 408-11 20" Playhouse Window Arch	6
	(CC-018) 408-12 24 1/2" Door Cross Piece	2
	408-13 30 3/8" Under Window Filler	25
	(CC-030) 408-14 44 1/2" Store Arch	1

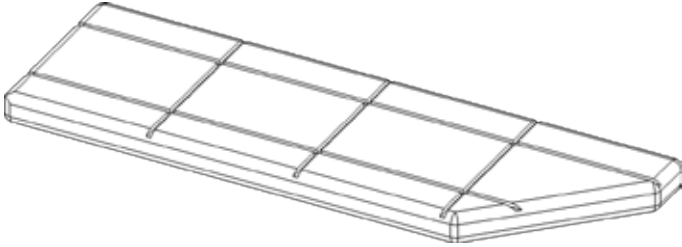
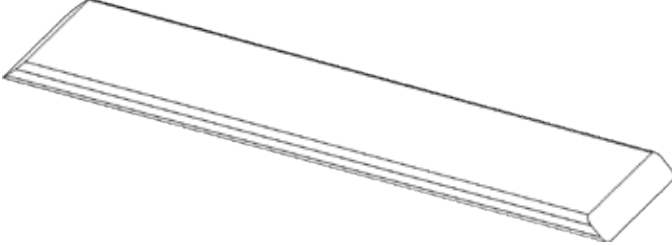
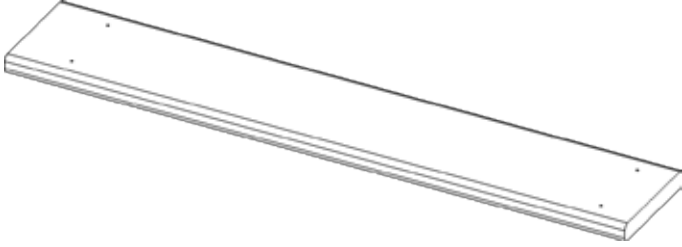
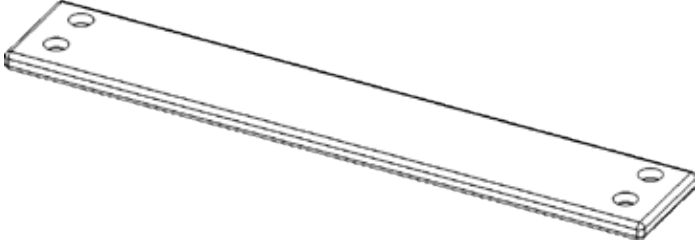
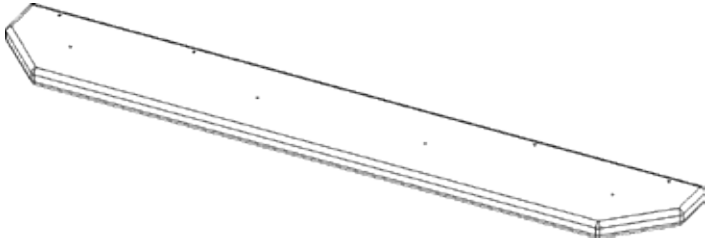
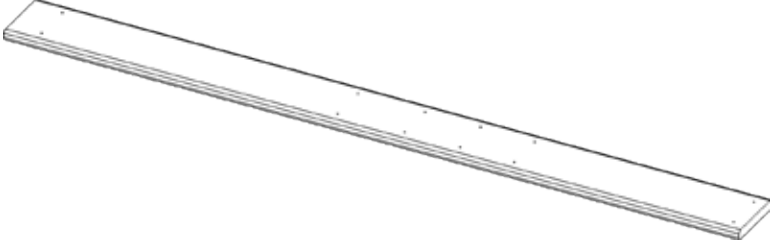
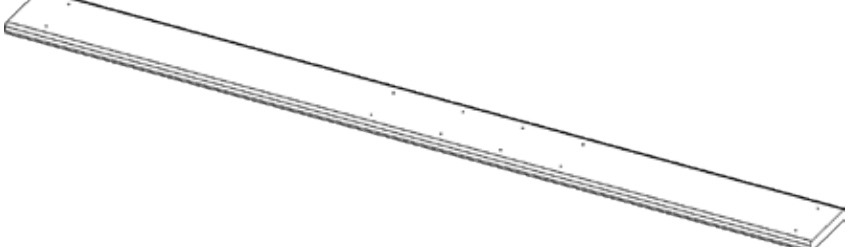

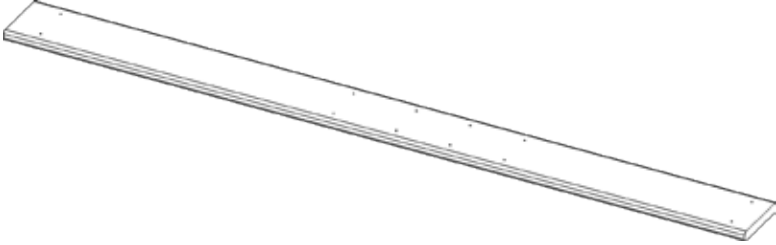
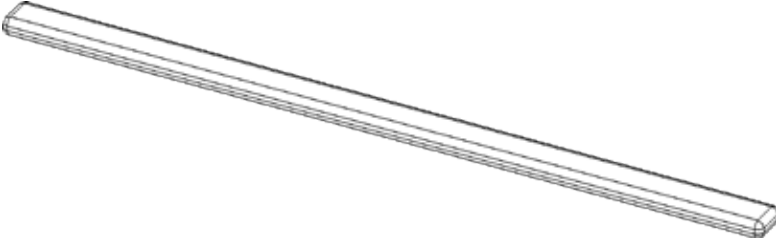
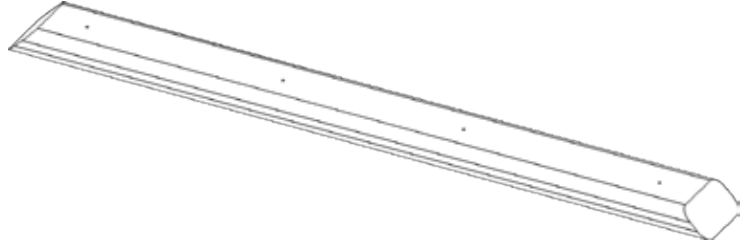
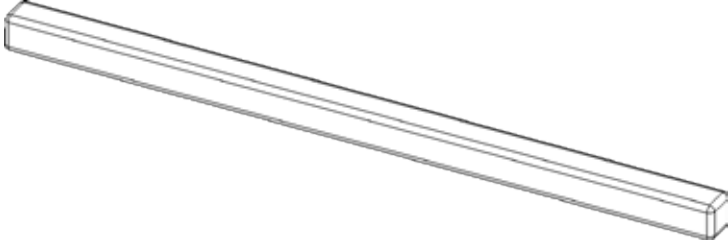
KSI-408 Playhouse Panel Lumber	Description	QTY.
	<p>408-15 64 1/8" Store End Board</p>	<p>2</p>
	<p>408-16 14" Above Window Filler- Door Side</p>	<p>4</p>
	<p>408-17 30 3/8" Lower Door Side Filler</p>	<p>4</p>
	<p>408-18 14" Upper Store Center Filler</p>	<p>1</p>
	<p>408-19 30 3/8" Store Lower Center Filler</p>	<p>1</p>
	<p>408-20 14" Store Upper Wide Filler</p>	<p>2</p>
	<p>408-21 17" Playhouse Left Shutter</p>	<p>7</p>

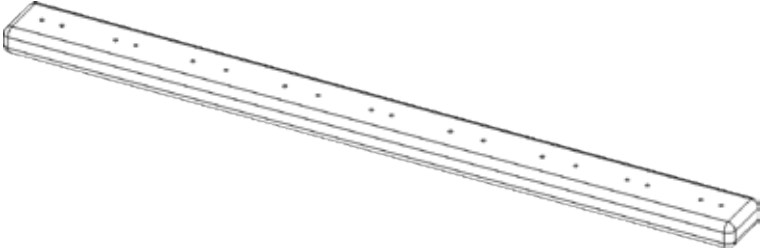
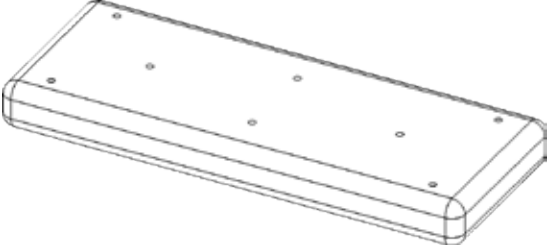
KSI-408 Playhouse Panel Lumber	Description	QTY.
	<p>408-22 17" Right Playhouse Shutter</p>	<p>7</p>
	<p>(CC-048) 408-23 24 1/2" Large Door Bottom Angled</p>	<p>1</p>
	<p>408-24 30 3/8" Playhouse Under Store Wide Board</p>	<p>2</p>
	<p>(CC-049) 408-25 32 1/8" Large Lower Door Side Crosspiece</p>	<p>1</p>
	<p>(CC-050) 408-26 35 1/4" Playhouse Store Counter</p>	<p>1</p>
	<p>408-27 63 11/16" Door Large Board</p>	<p>2</p>
	<p>408-28 64 1/4" Shutter Board- Wing Side</p>	<p>8</p>

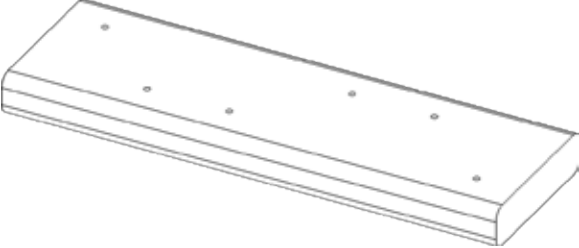
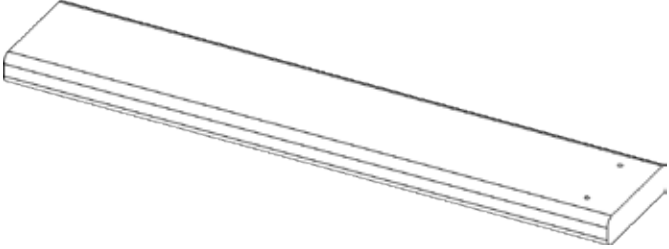
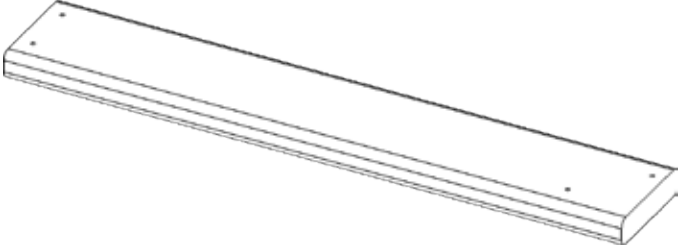
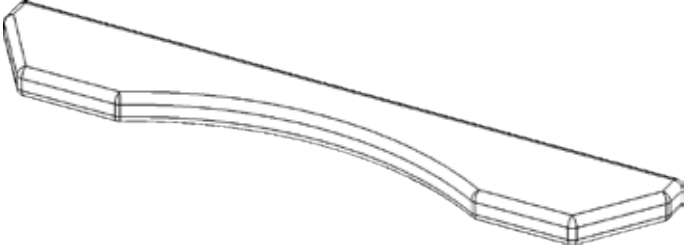
KSI-408 Playhouse Panel Lumber	Description	QTY.
	<p>408-29 65 5/8" Shutter Board</p>	<p>8</p>
	<p>(CC-090) 408-30 60 3/4' Lower Deck Filler</p>	<p>1</p>
	<p>(CC-108) 408-31 35" Store Counter Support</p>	<p>1</p>
	<p>408-32 67 7/8" Playhouse Panel Upright</p>	<p>1</p>

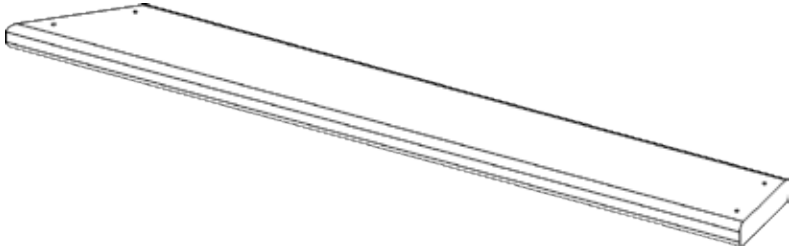
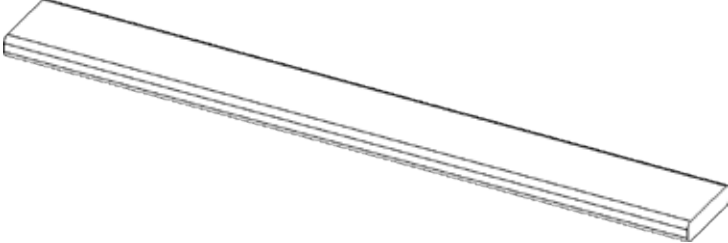
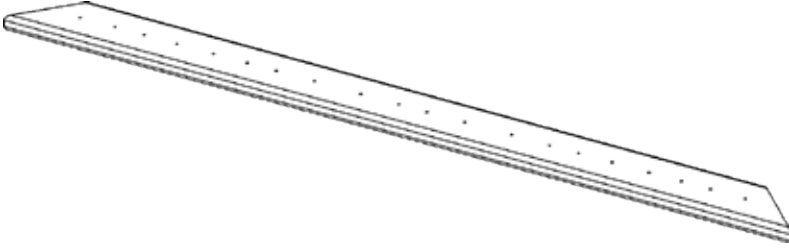
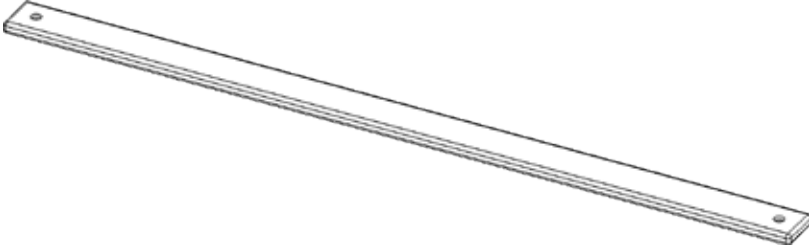
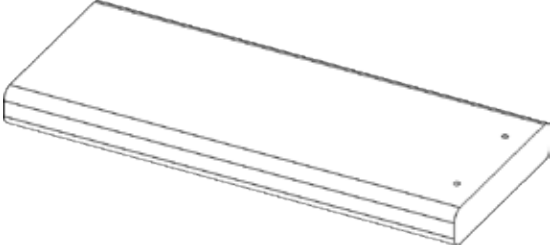
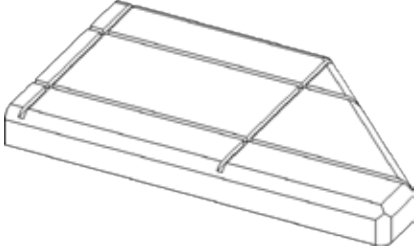
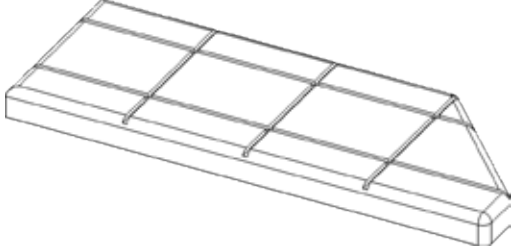
KSI-406 Treehouse Panel Lumber	Description	QTY.
	(CC-001) 406-1 24 13/16" Panel Filler Support	8
	406-2 8 3/4" Treehouse Center Holder	2
	406-3 10 1/2" Treehouse Panel Board #1	8
	406-4 10 1/2" Side Center Holder	2
	406-5 18" Side Center Panel Board	2
	406-6 19 1/2" Side Panel End Board	4
	(CC-016) 406-7 20" Window Arch	4

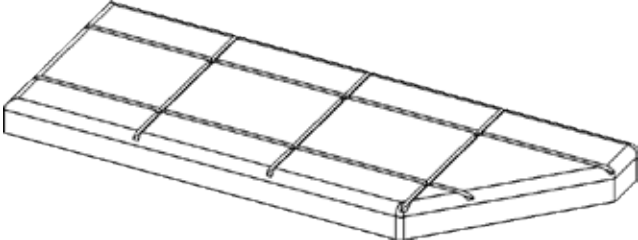
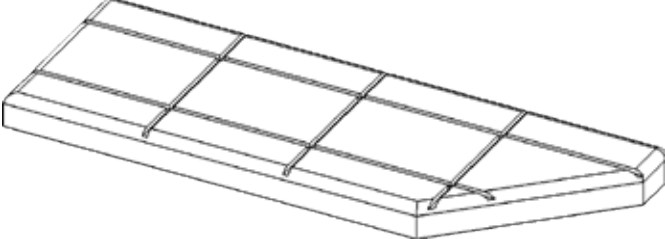
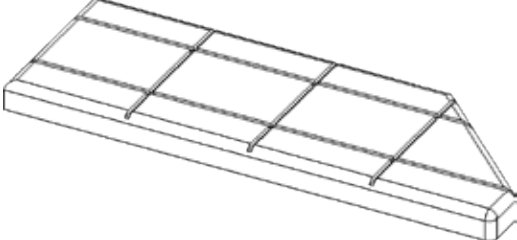
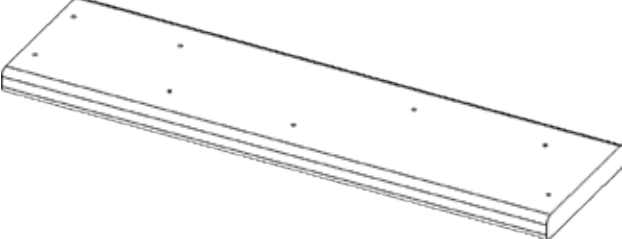
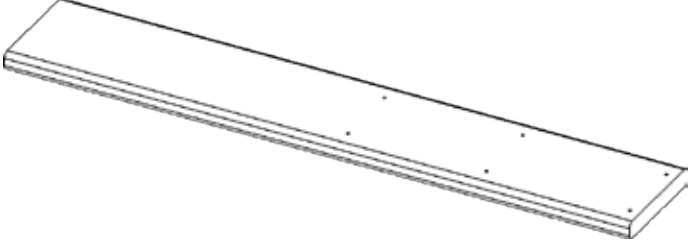
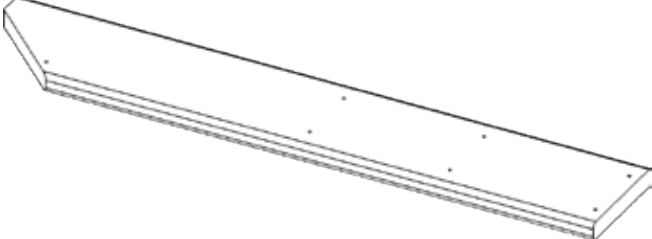
KSI-406 Treehouse Panel Lumber	Description	QTY.
	<p>406-8 26 1/4" End Treehouse Panel Board</p>	<p>4</p>
	<p>406-9 29" Center Panel Board</p>	<p>2</p>
	<p>406-10 45 3/8" Panel Board #2</p>	<p>2</p>
	<p>(CC-038) 406-11 60 1/4" Side Facia</p>	<p>2</p>
	<p>406-12 10 1/2" Center Panel Board</p>	<p>4</p>
	<p>406-13 9 1/8" Left SB Side Shutter</p>	<p>1</p>
	<p>(CC-057) 406-14 14" Side Left Shutter</p>	<p>3</p>

KSI-406 Treehouse Panel Lumber	Description	QTY.
	(CC-058) 406-15 14" Side Right Shutter	4
	406-16 15" Right Shutter	4
	406-17 15" Left Shutter	4
	406-18 19 1/2" Side Shutter Board	8
	406-19 30 1/2" Large Panel Board	4
	406-20 30 1/2" End Panel Board	4
	(CC-089) 406-21 27 1/2" Panel Filler	16

405-HWR-BAG 6.5 BENGAL FORT BASE HARDWARE

INSTALLER NOTE: (YOU MUST ASSEMBLE THIS PRODUCT IN ACCORDANCE WITH THESE ASSEMBLY INSTRUCTIONS. WHEN COMPLETE GIVE MANUAL TO OWNER.)

A-1
3/8" Acorn Nut Plated
QTY. 8



A-2
1/2" Acorn Nut Plated
QTY. 14

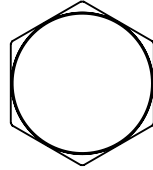

A-3
3/8" x 5" Carriage Bolt
QTY. 4

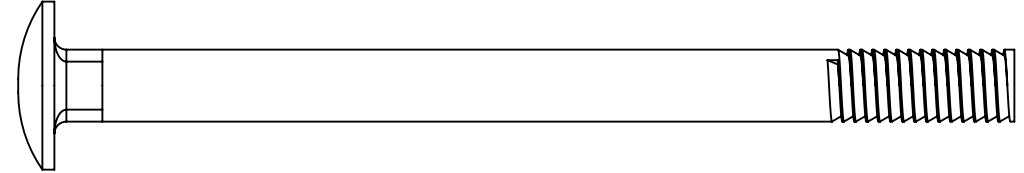

A-4
1/2" x 4 1/2" Carriage Bolt
QTY. 2

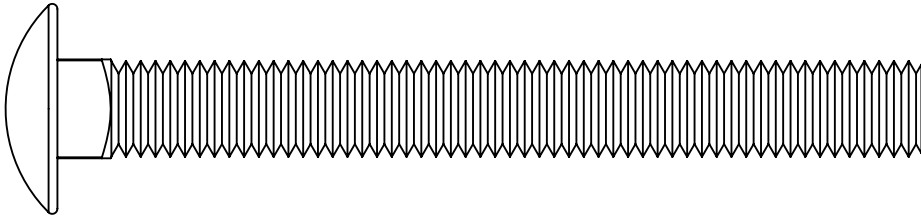

A-7
3/8" Hex Nut
QTY. 4



A-9
1/4" x 2" Hex Lag Screw
QTY. 4

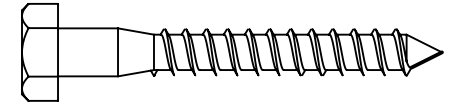

A-5
1/2" x 7" Carriage Bolt
QTY. 9

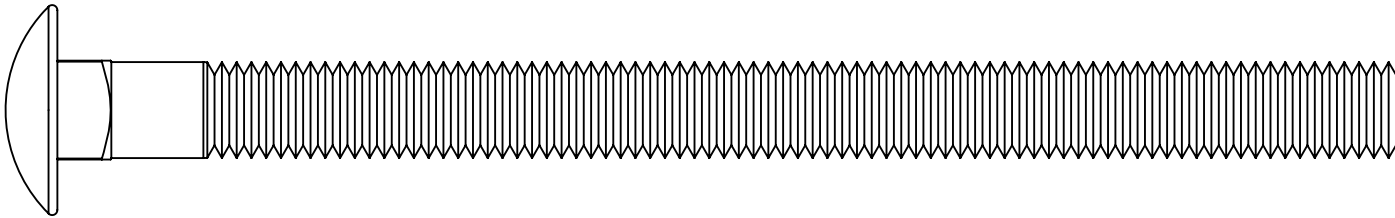

A-10
3/8" Nylon Insert Locknut
QTY. 4



A-8
3/8" x 5" Hex Bolt
QTY. 4

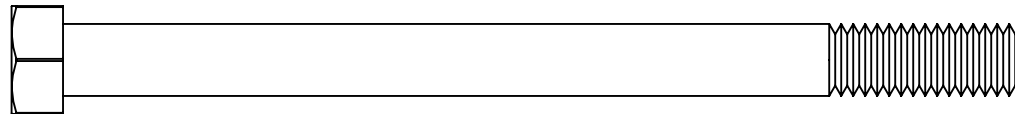

405-HWR-BAG 6.5 BENGAL FORT BASE HARDWARE

INSTALLER NOTE: (YOU MUST ASSEMBLE THIS PRODUCT IN ACCORDANCE WITH THESE ASSEMBLY INSTRUCTIONS. WHEN COMPLETE GIVE MANUAL TO OWNER.)

A-6
1/2" x 8" Carriage Bolt
QTY. 3

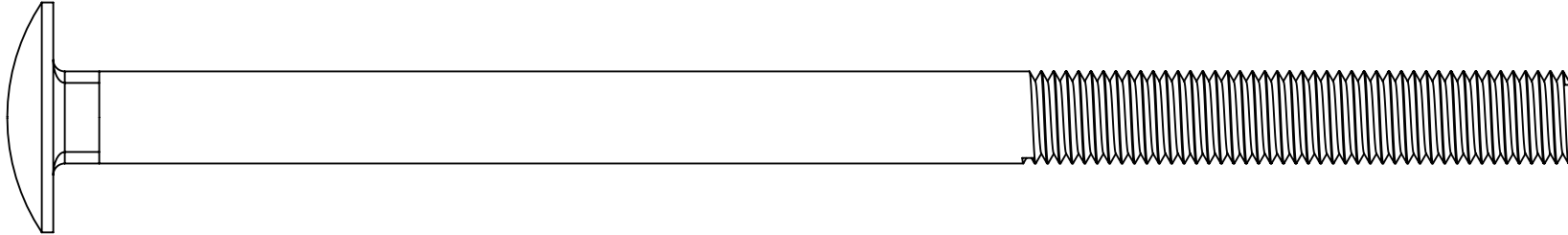

A-11
3/8" Split Lockwasher
QTY. 8

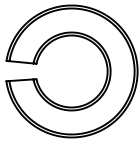

A-12
3/8" Bolt Cup
QTY. 4

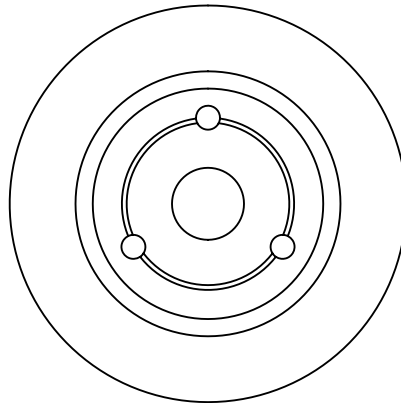

A-13
8 x 80mm Spring Clip
QTY. 2

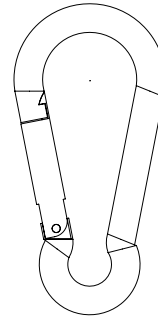

A-14
#2 & 3 Drive Bit
QTY. 1



Bag B
1 1/2" Coated Deck Screw
QTY. 156



Bag C
2" Coated Deck Screw
QTY. 8

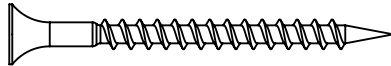

Bag D
2 1/2" Coated Deck Screw
QTY. 318



Bag E
1/2" Hex Nut
QTY. 14

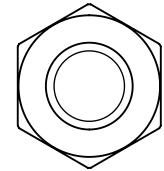

405-HWR-BAG 6.5 BENGAL FORT BASE HARDWARE

INSTALLER NOTE: (YOU MUST ASSEMBLE THIS PRODUCT IN ACCORDANCE WITH THESE ASSEMBLY INSTRUCTIONS. WHEN COMPLETE GIVE MANUAL TO OWNER.)

Bag F
1/4" x 3" Hex Lag Screw
QTY. 22

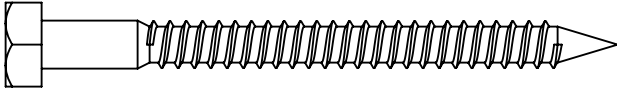

Bag G
1/4" x 4 1/2" Hex Lag Screw
QTY. 58

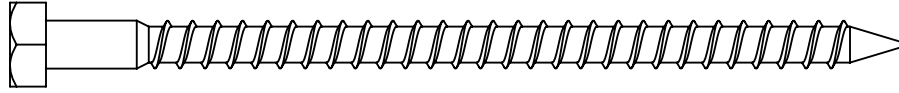

BAG H
3/8" x 3 1/2" Hex Lag Screw
QTY. 83

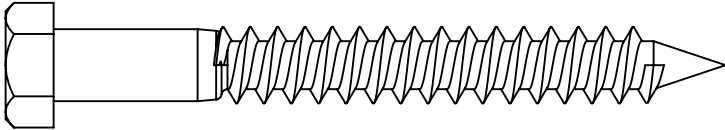

Bag I
3/8" x 5" Hex Lag Screw
QTY. 12

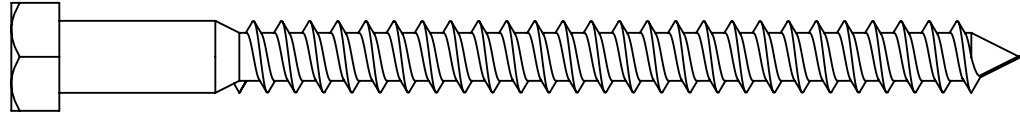

Bag J
#14 x 2" Pan Phillips T/S
QTY. 17

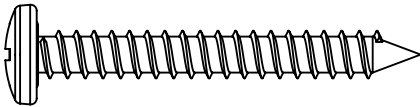

Bag K
1/4" x 1 1/4" Pan Phillips M/S
QTY. 36

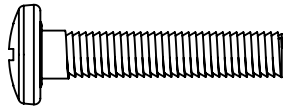

Bag L
1/4" T-Nut
QTY. 36

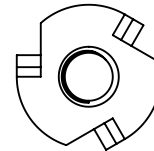

Bag M
1/2" Split Lockwasher
QTY. 19

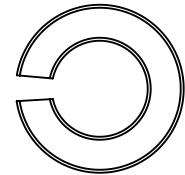

Bag N
1/4" USS Flatwasher
QTY. 155

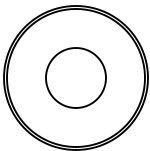

Bag O
3/8" USS Flatwasher
QTY. 103

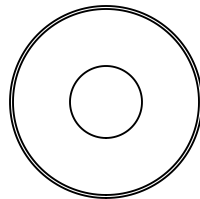

Bag P
1/2" USS Flatwasher
QTY. 18

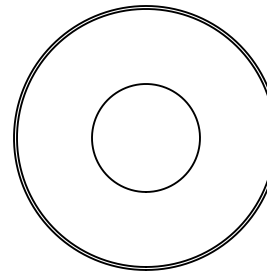

Bag Q
3/4" USS Flatwasher
QTY. 14

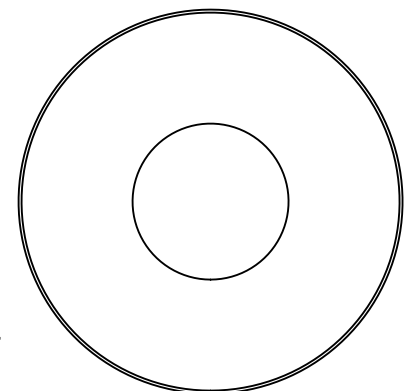

MEASUREMENT TAKEN FROM BOTTOM OF BOLT HEAD TO THE BOTTOM OF BOLT

USE THE RULER TO MEASURE YOUR BOLTS AND SCREWS. HARDWARE VIEWS SHOWN ABOVE ARE 1:1 SCALE AND CAN BE USED TO MATCH HARDWARE SIZES.

404-SB-HWR 5.8 SWINGBEAM HARDWARE

INSTALLER NOTE: (YOU MUST ASSEMBLE THIS PRODUCT IN ACCORDANCE WITH THESE ASSEMBLY INSTRUCTIONS. WHEN COMPLETE GIVE MANUAL TO OWNER.)

SB-1
3/8" Acorn Nut Plated
QTY. 10



SB-2
1/2" Acorn Nut Plated
QTY. 9

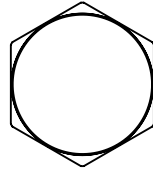

SB-3
1/2" x 3 1/2" Carriage Bolt
QTY. 2

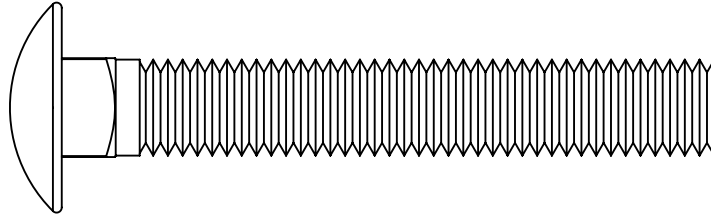

SB-6
3/8" Hex Nut
QTY. 2



SB-4
1/2" x 7" Carriage Bolt
QTY. 5

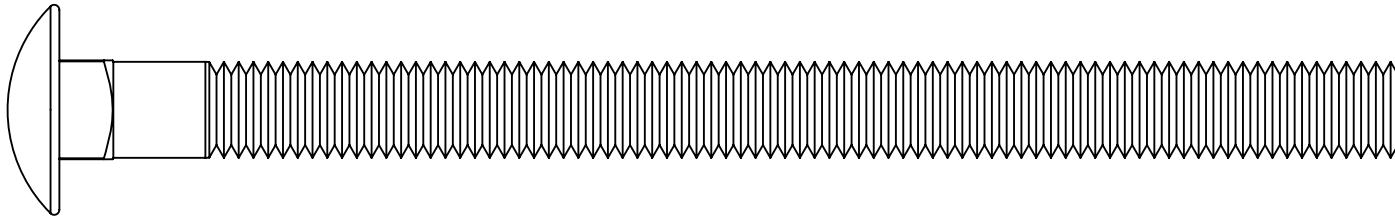

SB-7
1/2" Hex Nut
QTY. 9

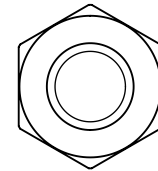

SB-5
1/2" x 9" Carriage Bolt
QTY. 1

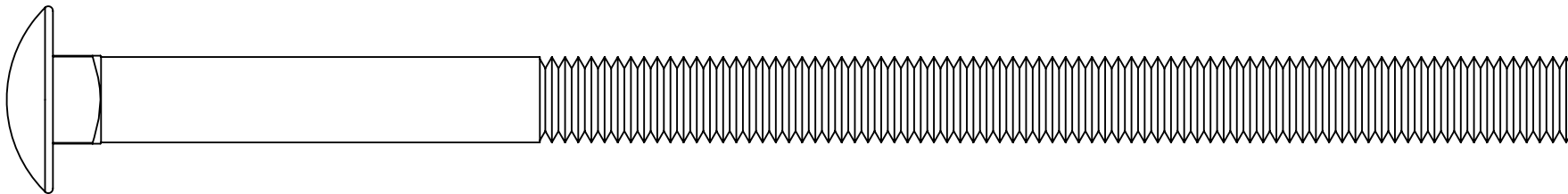

MEASUREMENT TAKEN FROM BOTTOM OF BOLT HEAD TO THE BOTTOM OF BOLT

USE THE RULER TO MEASURE YOUR BOLTS AND SCREWS. HARDWARE VIEWS SHOWN ABOVE ARE 1:1 SCALE AND CAN BE USED TO MATCH HARDWARE SIZES.

404-SB-HWR 5.8 SWINGBEAM HARDWARE

INSTALLER NOTE: (YOU MUST ASSEMBLE THIS PRODUCT IN ACCORDANCE WITH THESE ASSEMBLY INSTRUCTIONS. WHEN COMPLETE GIVE MANUAL TO OWNER.)

SB-8
3/8" x 7" Hex Bolt
QTY. 8

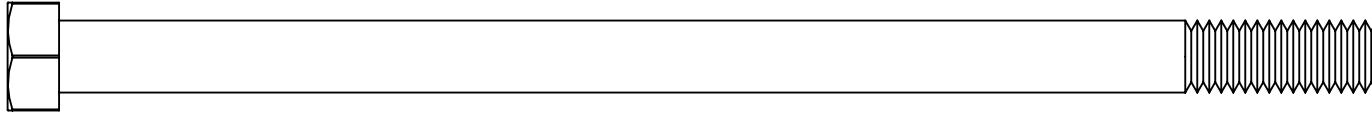

SB-13
3/8" Nylon Insert Locknut
QTY. 7



SB-9
3/8" x 10" Hex Bolt
QTY. 2

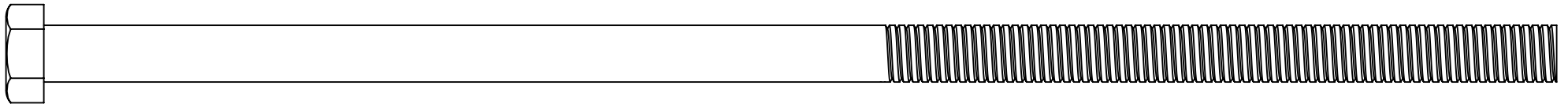

SB-10
1/2" x 11 1/2" Hex Bolt
QTY. 1

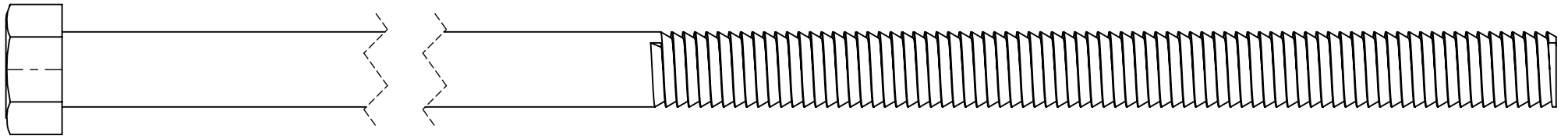

SB-11
3/8" x 3 1/2" Hex Lag Screw
QTY. 2

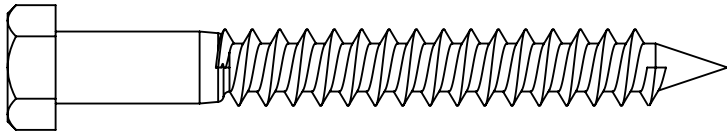

SB-12
3/8" x 5" Hex Lag Screw
QTY. 2

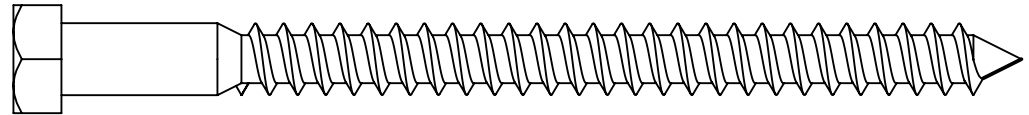

MEASUREMENT TAKEN FROM BOTTOM OF BOLT HEAD TO THE BOTTOM OF BOLT

USE THE RULER TO MEASURE YOUR BOLTS AND SCREWS. HARDWARE VIEWS SHOWN ABOVE ARE 1:1 SCALE AND CAN BE USED TO MATCH HARDWARE SIZES.

404-SB-HWR 5.8 SWINGBEAM HARDWARE

INSTALLER NOTE: (YOU MUST ASSEMBLE THIS PRODUCT IN ACCORDANCE WITH THESE ASSEMBLY INSTRUCTIONS. WHEN COMPLETE GIVE MANUAL TO OWNER.)

SB-14
#14 x 1" Pan Phillips T/S
QTY. 2

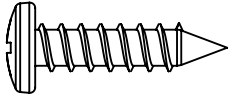

SB-15
3/8" Split Lockwasher
QTY. 10



SB-16
1/2" Split Lockwasher
QTY. 9

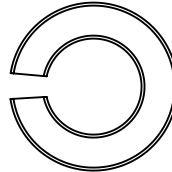

SB-17
3/8" USS Flatwasher
QTY. 14

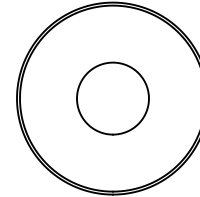

SB-18
1/2" USS Flatwasher
QTY. 10

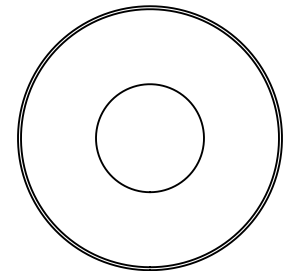

SB-19
3/4" USS Flatwasher
QTY. 8

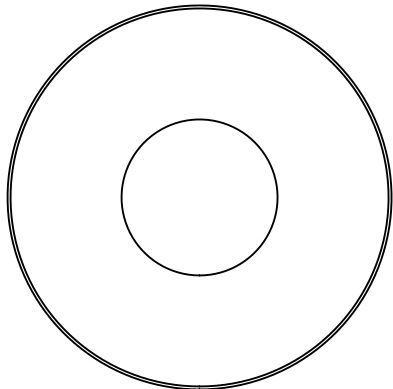

SB-20
3/8" Bolt Cup
QTY. 20

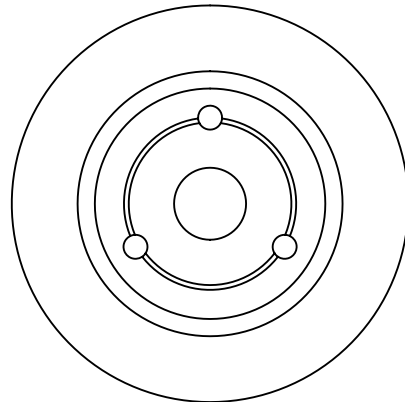

SB-21
8 x 80mm Spring Clip
QTY. 4

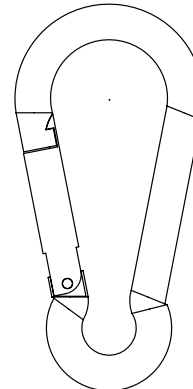

MEASUREMENT TAKEN FROM BOTTOM OF BOLT HEAD TO THE BOTTOM OF BOLT

USE THE RULER TO MEASURE YOUR BOLTS AND SCREWS. HARDWARE VIEWS SHOWN ABOVE ARE 1:1 SCALE AND CAN BE USED TO MATCH HARDWARE SIZES.

407-HWR-BAG PLAYHOUSE PANEL HARDWARE

INSTALLER NOTE: (YOU MUST ASSEMBLE THIS PRODUCT IN ACCORDANCE WITH THESE ASSEMBLY INSTRUCTIONS. WHEN COMPLETE GIVE MANUAL TO OWNER.)

PP-1
90 Degree Bracket
QTY. 2

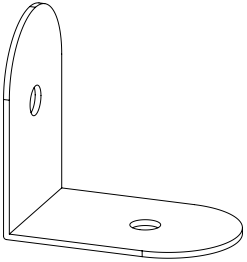

PP-2
1 5/8" Coated Deck Screw
QTY. 424

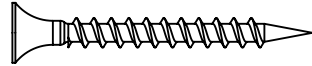

PP-3
2" Coated Deck Screw
QTY. 8



PP-4
3/8" x 3 1/2" Hex Lag Screw
QTY. 20

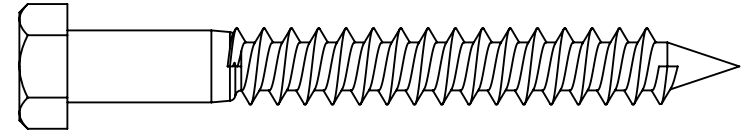

PP-5
#14 x 1" Pan Phillips T/S
QTY. 16

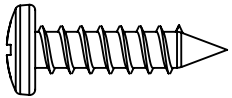

PP-6
1/4" USS Flatwasher
QTY. 4

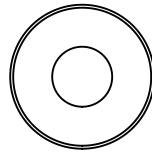

PP-7
3/8" USS Flatwasher
QTY. 20

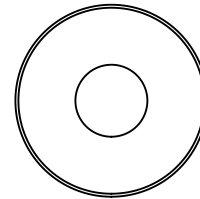

PP-8
Hinges w/ Handles and Screws
QTY. 1

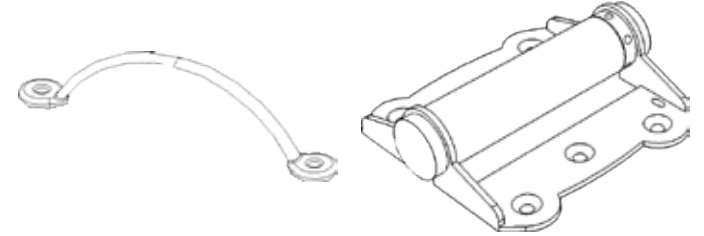

PP-9
#2 & 3 Drive Bit
QTY. 1



MEASUREMENT TAKEN FROM BOTTOM OF BOLT HEAD TO THE BOTTOM OF BOLT

USE THE RULER TO MEASURE YOUR BOLTS AND SCREWS. HARDWARE VIEWS SHOWN ABOVE ARE 1:1 SCALE AND CAN BE USED TO MATCH HARDWARE SIZES.

406-HWR-BAG TREEHOUSE PANEL HARDWARE

INSTALLER NOTE: (YOU MUST ASSEMBLE THIS PRODUCT IN ACCORDANCE WITH THESE ASSEMBLY INSTRUCTIONS. WHEN COMPLETE GIVE MANUAL TO OWNER.)

TP-1
1 1/2" Coated Deck Screw
QTY. 385



TP-2
2" Coated Deck Screw
QTY. 36



TP-3
1/4" x 3" Hex Lag Screw
QTY. 4

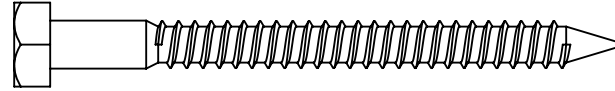

TP-4
1/4" USS Flatwasher
QTY. 4

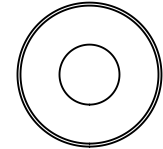







TP-5
#2 & 3 Drive Bit
QTY. 1

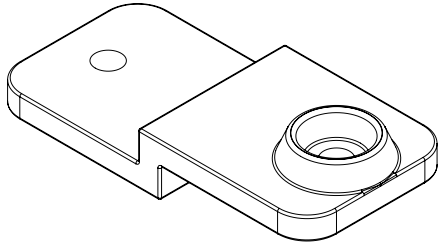
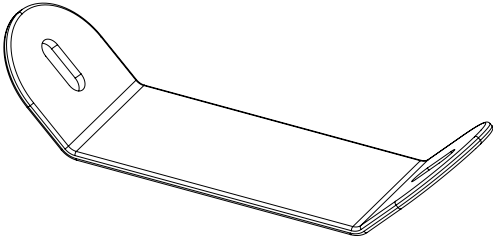
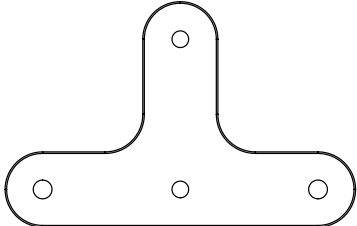
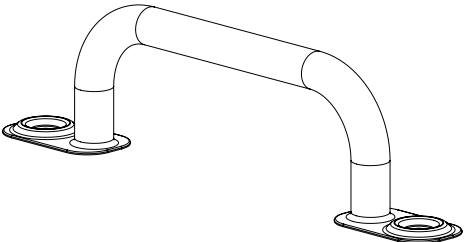

MEASUREMENT TAKEN FROM BOTTOM OF BOLT HEAD TO THE BOTTOM OF BOLT

USE THE RULER TO MEASURE YOUR BOLTS AND SCREWS. HARDWARE VIEWS SHOWN ABOVE ARE 1:1 SCALE AND CAN BE USED TO MATCH HARDWARE SIZES.

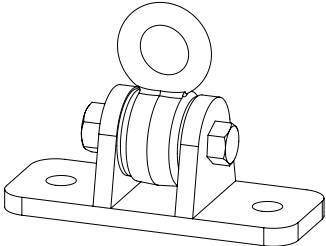
405- 6.5 Bengal Fort Accessories	Description	QTY.
	<p>405-A Fort Ladder Bracket</p>	<p>2</p>
	<p>405-B 45 Degree Swingbeam Bracket</p>	<p>2</p>
	<p>405-C Swingbeam T-Plate</p>	<p>1</p>
	<p>405-D Playgrip Safety Handle</p>	<p>5</p>
	<p>405-E Playgrip Ladder Handle</p>	<p>2</p>
	<p>405-F 16' Yellow Rope</p>	<p>2</p>
	<p>405-G 20" Trapeze Bar</p>	<p>1</p>

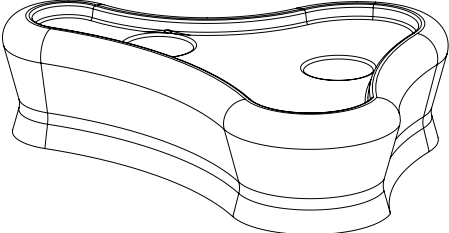
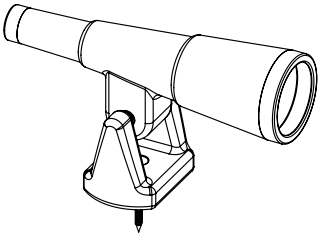
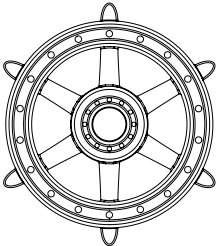
Picture	Description	QTY.
	<p>405-H Disc Swing</p>	<p>1</p>
	<p>405-I Ductile Iron Swing Hanger</p>	<p>6</p>
	<p>405-J 84" Chained Belt Swing</p>	<p>2</p>
	<p>405-K Rockwall Rocks</p>	<p>15</p>
	<p>405-L Telescope</p>	<p>1</p>
	<p>405-M 19" Ships' Wheel</p>	<p>1</p>

Ladder Assembly

PARTS NEEDED

405-48- 101" Right Ladder Leg-	(1)	405-47- 101" Left Ladder Leg-	(1)
CC-123- 21 9/16" Step-	(7)	CC-084- 50 1/8" 1- Rock Rockwall Board-	(7)
CC-085- 50 1/8" 2- Rock Rockwall Board-	(4)		

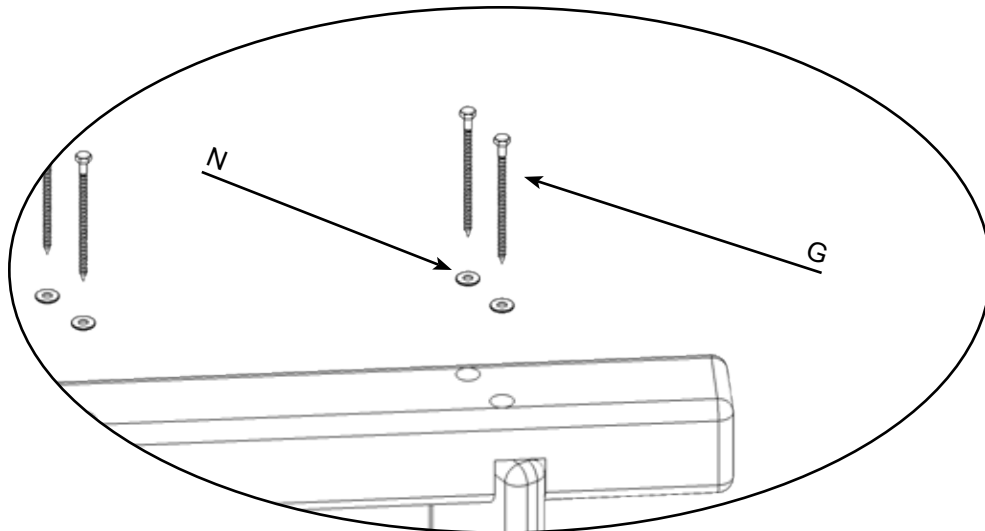
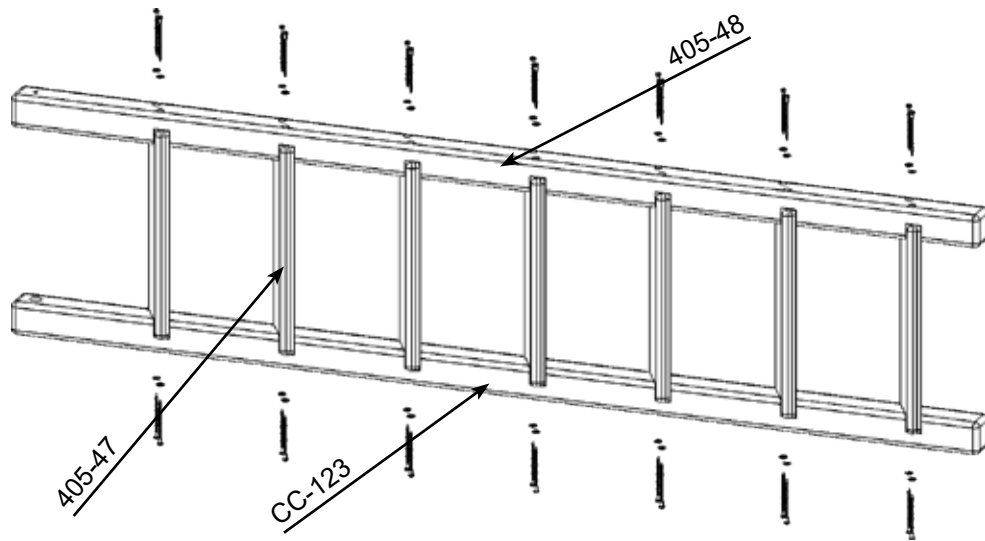

Rockwall Boards

HARDWARE NEEDED

(1)	G- 1/4" x 4 1/2" Hex Lag Screw-	(28)
(7)	N- 1/4" USS Flatwasher-	(58)
	K- 1/4" x 1 1/4" Pan Phillips M/S-	(30)
	L- 1/4" T-Nut-	(30)

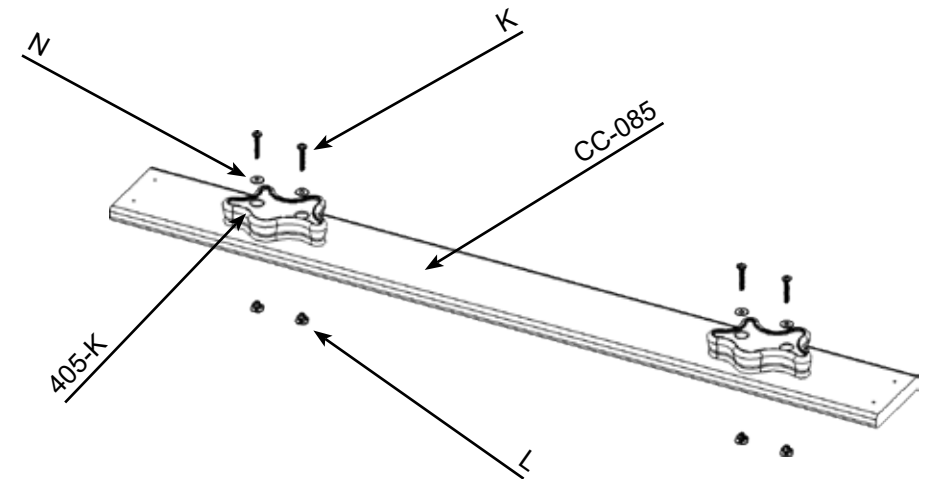
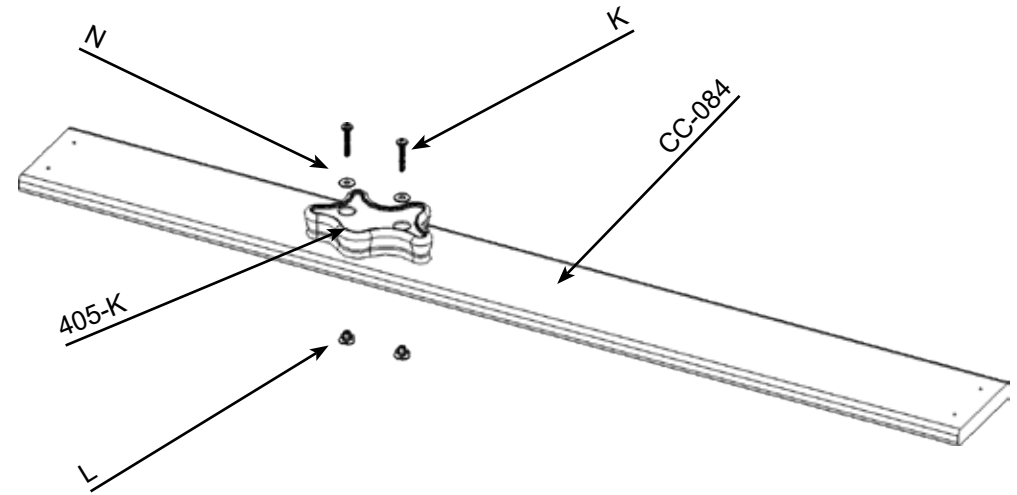

Rockwall Assembly

PARTS NEEDED

405-46- 95 3/16" Right Rockwall Leg-	(1)	405-45- 95 3/16" Left Rockwall Leg-	(1)
405-1- 50 1/8" Small Blank Rockwall Board-	(1)	CC-085- 50 1/8" 2- Rock Rockwall Board-	(4)
CC-084- 50 1/8" 1- Rock Rockwall Board-	(7)	CC-086- 50 1/8" Blank Rockwall Board-	(4)
CC-087- 50 1/8" Rope Hole Rockwall Board-	(1)	CC-104- 30" Deck Runner-	(4)
CC-124- 54" Deck Board-	(6)	CC-122- 30" Center Deck Support-	(2)
CC-114- 54" Deck Board-	(8)		

Deck Assembly (Make 2 Assemblies)

HARDWARE NEEDED

D- 2 1/2" Coated Deck Screw-	(124)
------------------------------	-------

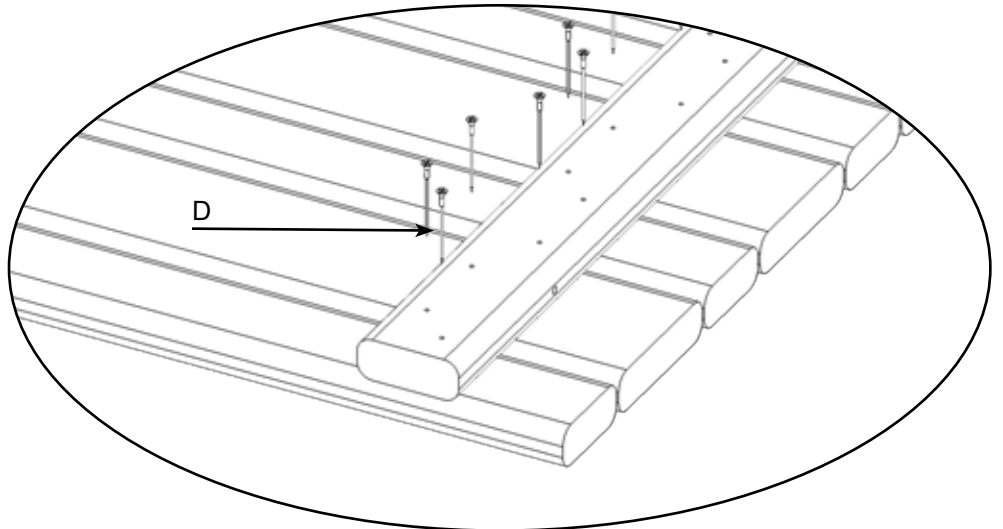
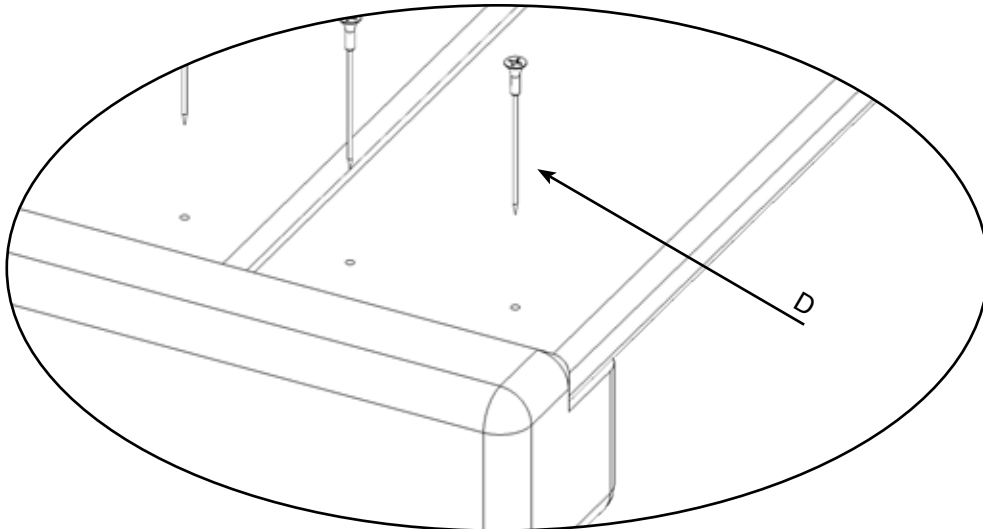
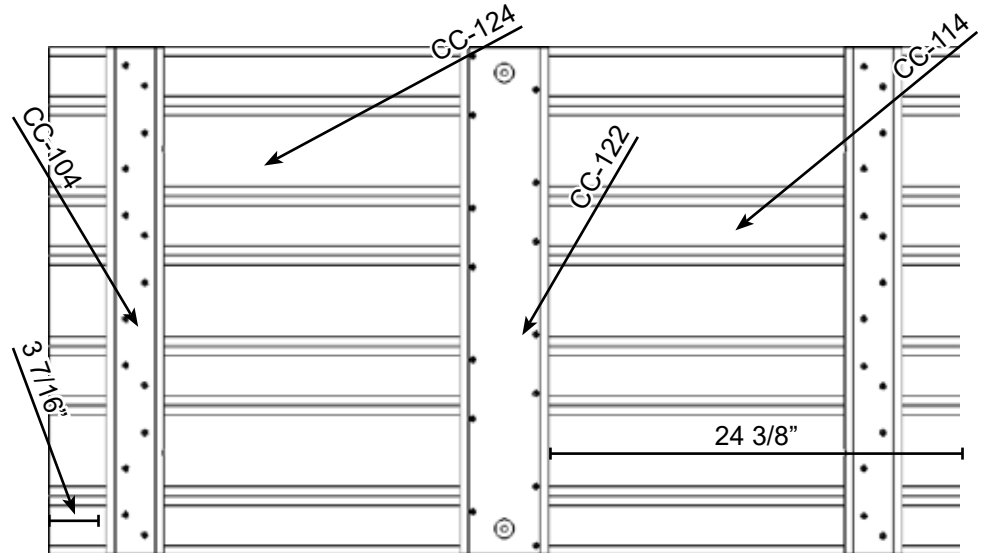
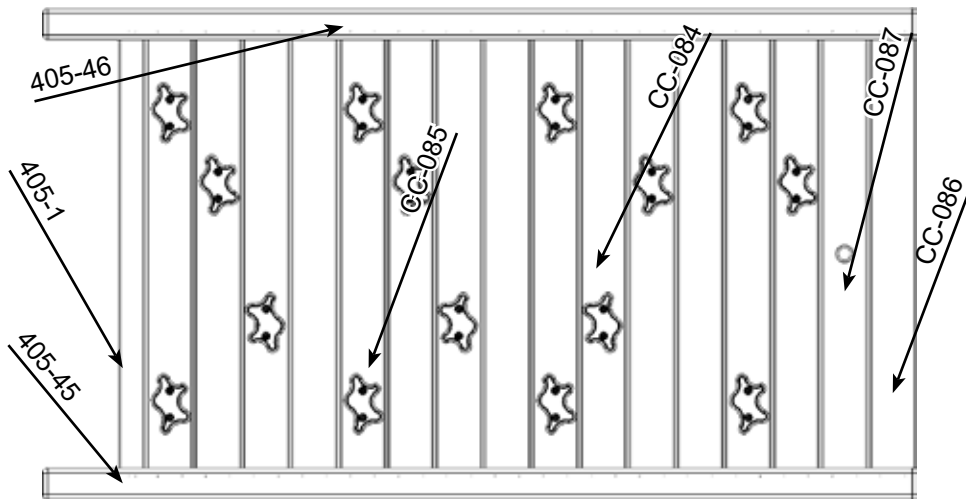

Wood Roof Fan (Make 2 assemblies)

PARTS NEEDED

- CC-051- 7 3/16" Center Fan Cap- (2)
- CC-041- 42 1/2" Bottom Fan Cap- (2)
- CC-015- 18" Center Fan Board- (2)
- CC-003- 12 1/8" Long Fan Board- (4)

HARDWARE NEEDED

- B- 1 1/2" Coated Deck Screw- (24)

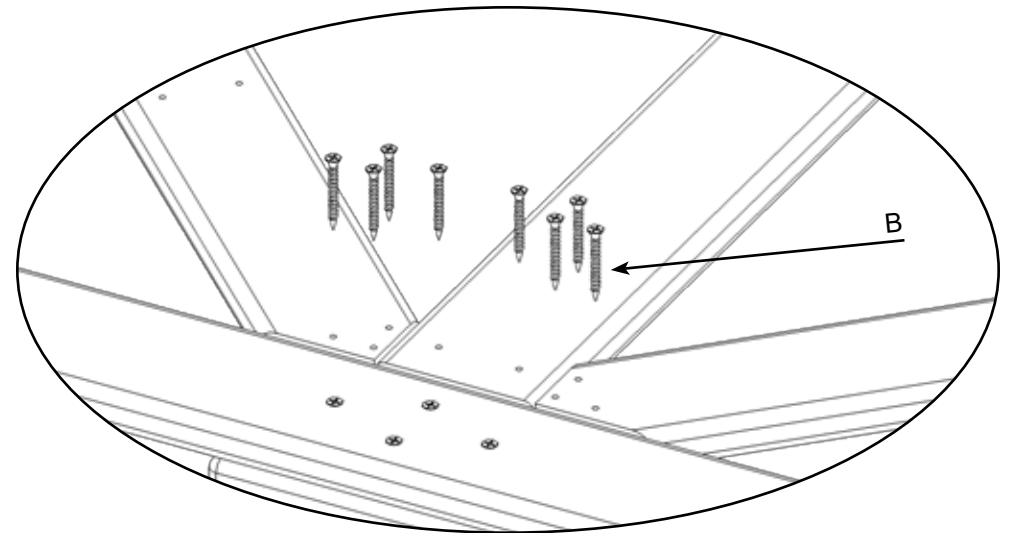
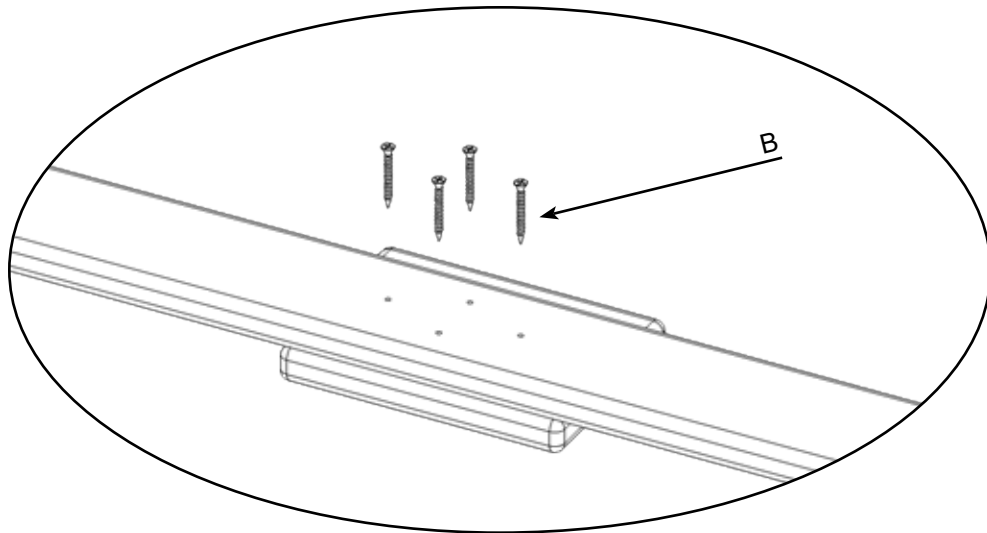
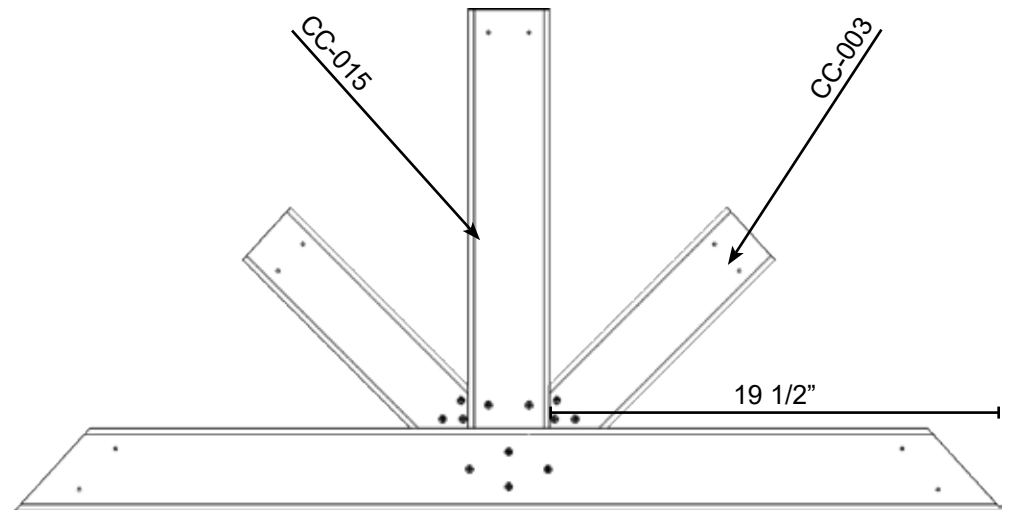
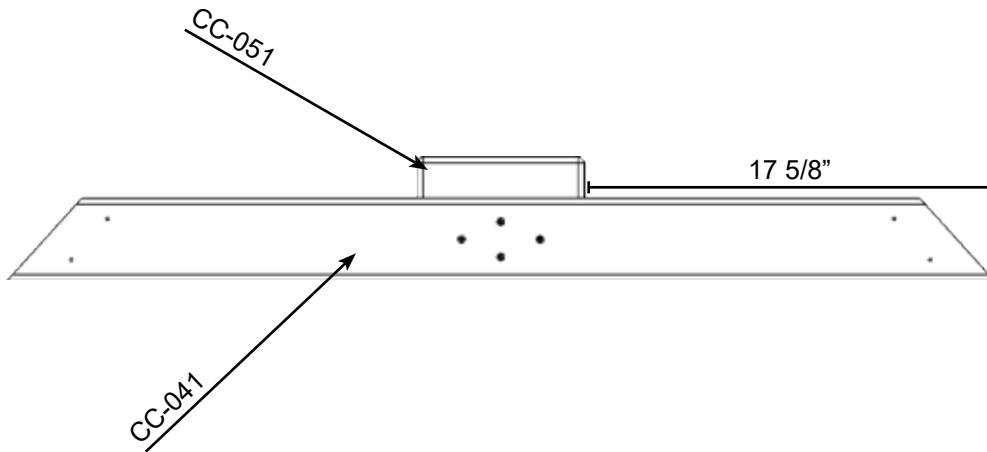

A-Frame Block Assembly

PARTS NEEDED

- CC-240- 7 7/8" Center A-Frame Block- (1)
- CC-244- 13 3/8" A-Frame Block Sunk- (1)
- CC-243- 13 3/8" A-Frame Block- (1)
- CC-184- 132 5/8" Universal Swingbeam- (1)
- 405-I- Ductile Iron Swing Hanger- (4)

- SB-9- 3/8" x 10" Hex Bolt- (1)
- SB-17- 3/8" USS Flatwasher- (9)
- SB-6- 3/8" Hex Nut- (1)
- SB-8- 3/8" x 7" Hex Bolt- (8)

Beam Assembly

HARDWARE NEEDED

- (1) SB-20- 3/8" Bolt Cup- (9)
- (9) SB-15- 3/8" Split Lockwasher- (9)
- (1) SB-1- 3/8" Acorn Nut Plated- (9)
- (8) SB-13- 3/8" Nylon Insert Locknut- (8)

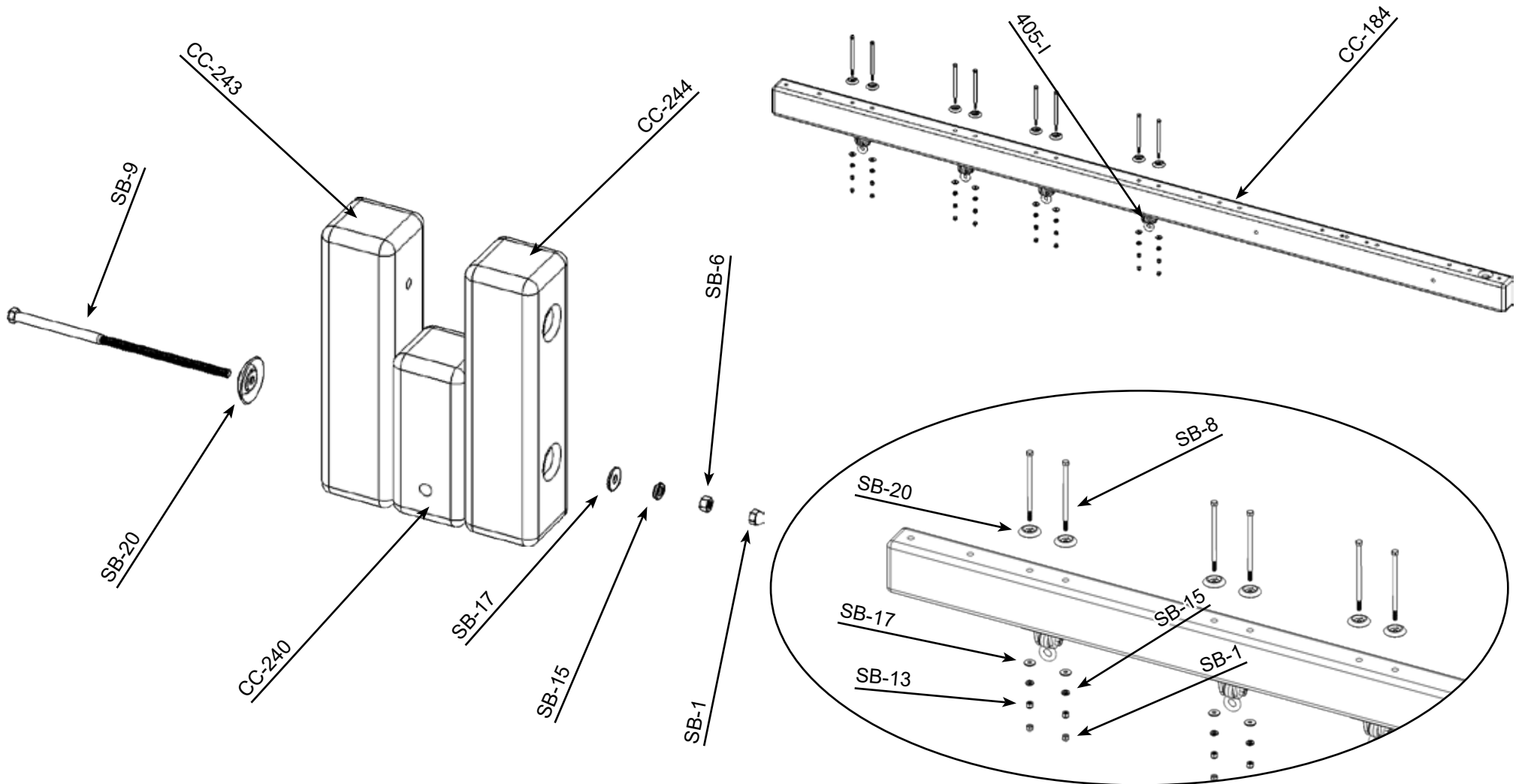

A-Frame Assembly

PARTS NEEDED

Beam Assembly-	(1)	SB-9- 3/8" x 10" Hex Bolt-
Block Assembly-	(1)	SB-17- 3/8" USS Flatwasher-
CC-246- 143" A-Frame Leg-	(2)	SB-6- 3/8" Hex Nut-
405-B- 45 Degree Swingbeam Bracket-	(2)	SB-10- 1/2" x 11 1/2" Hex Bolt-
		SB-19- 3/4" USS Flatwasher-
		SB-4- 1/2" x 7" Carriage Bolt-
		SB-2- 1/2" Acorn Nut Plated-

HARDWARE NEEDED

(1)	SB-20- 3/8" Bolt Cup-	(1)
(1)	SB-15- 3/8" Split Lockwasher-	(1)
(1)	SB-1- 3/8" Acorn Nut Plated-	(1)
(1)	SB-18- 1/2" USS Flatwasher-	(4)
(1)	SB-16- 1/2" Split Lockwasher-	(3)
(2)	SB-7- 1/2" Hex Nut-	(3)
(3)		

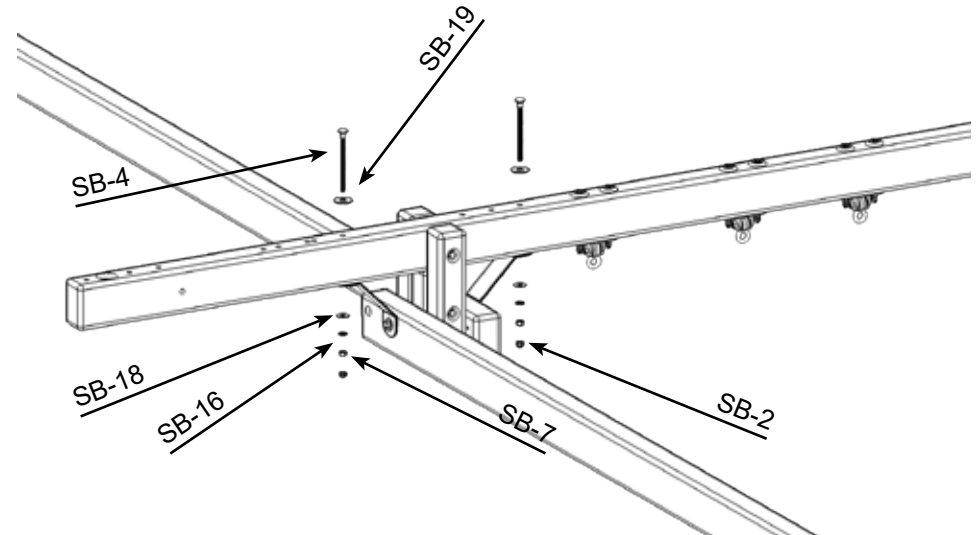
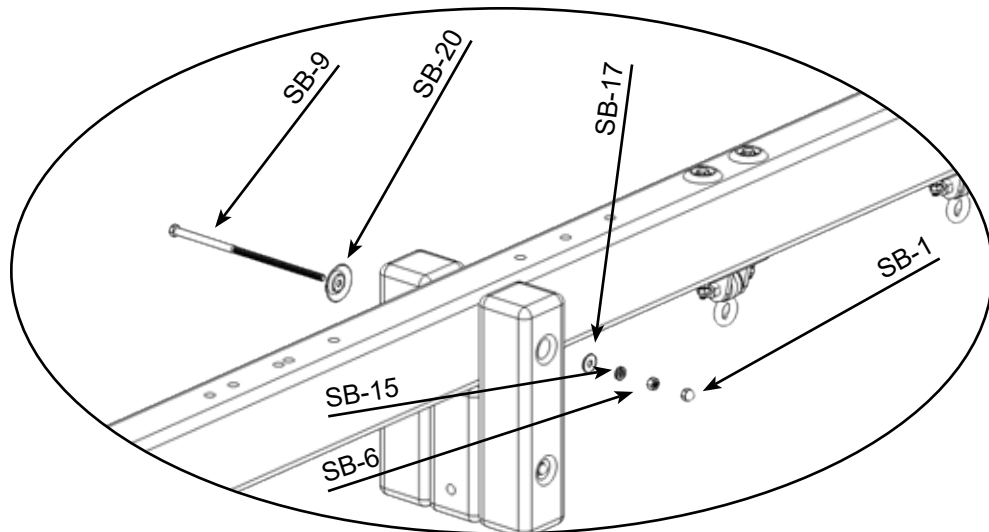
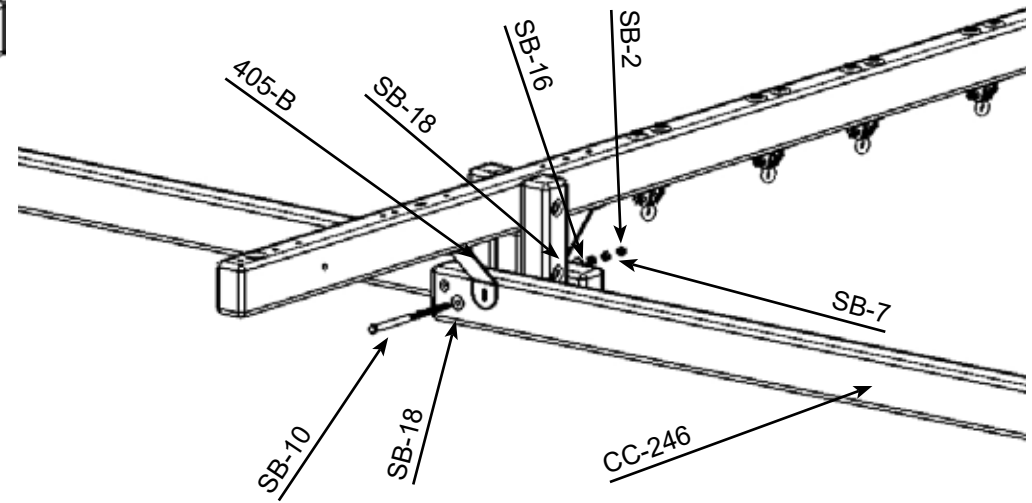
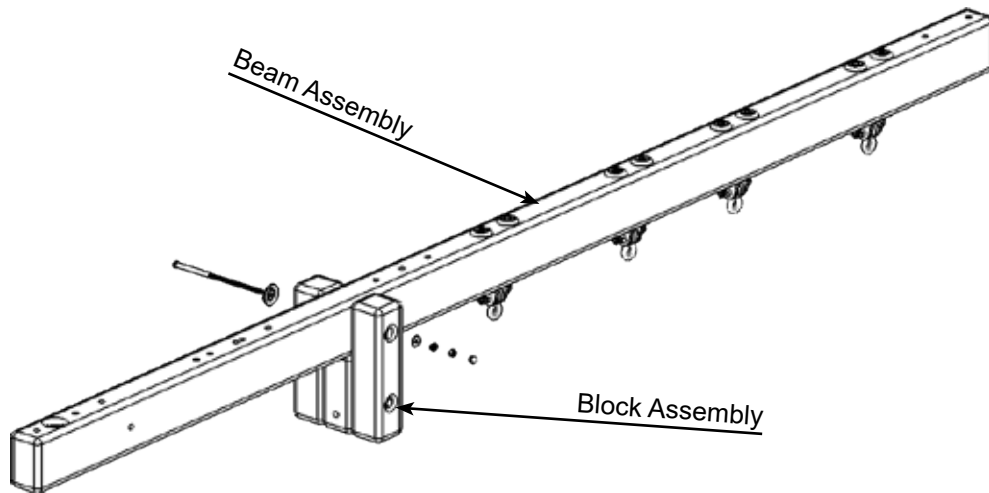

Swingbeam Side Wall

PARTS NEEDED

CC-160- 60 1/4" SB Top Joist-	(1)
405-50- 128" Corner Post-	(2)
405-35- 150 3/4" Short Wing Runner-	(1)
405-36- 155 7/8" Long Wing Runner-	(1)
CC-187- 60 1/4" Mainbeam-	(1)

HARDWARE NEEDED

A-5- 1/2" x 7" Carriage Bolt-	(4)	Q- 3/4" USS Flatwasher-	(4)
P- 1/2" USS Flatwasher-	(4)	M- 1/2" Split Lockwasher-	(4)
E- 1/2" Hex Nut-	(4)	A-2- 1/2" Acorn Nut Plated-	(4)
O- 3/8" USS Flatwasher-	(8)	H- 3/8" x 3 1/2" Hex Lag Screw-	(8)

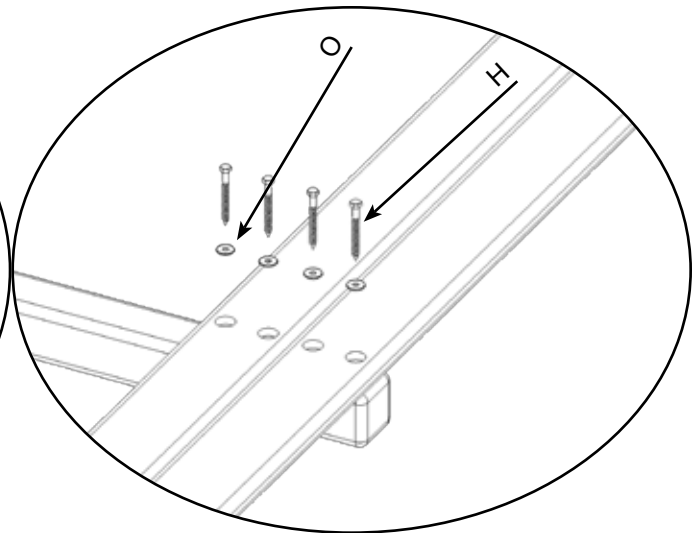
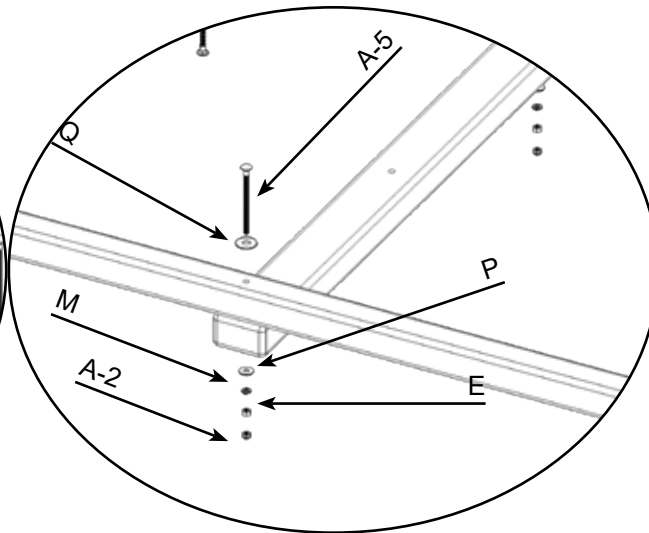
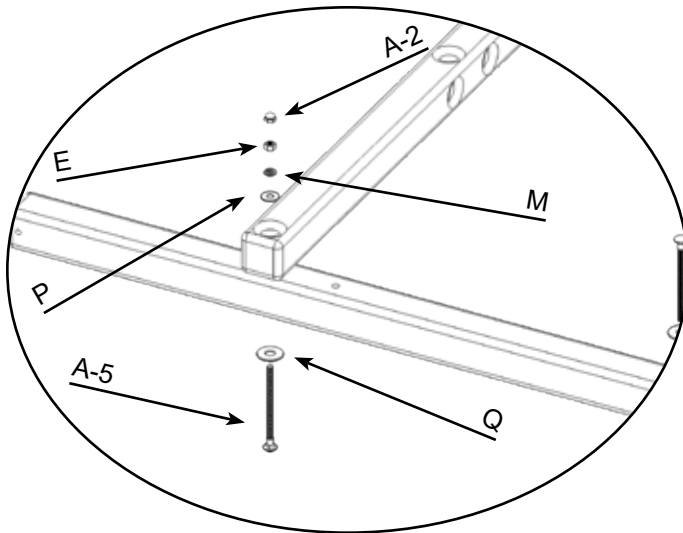
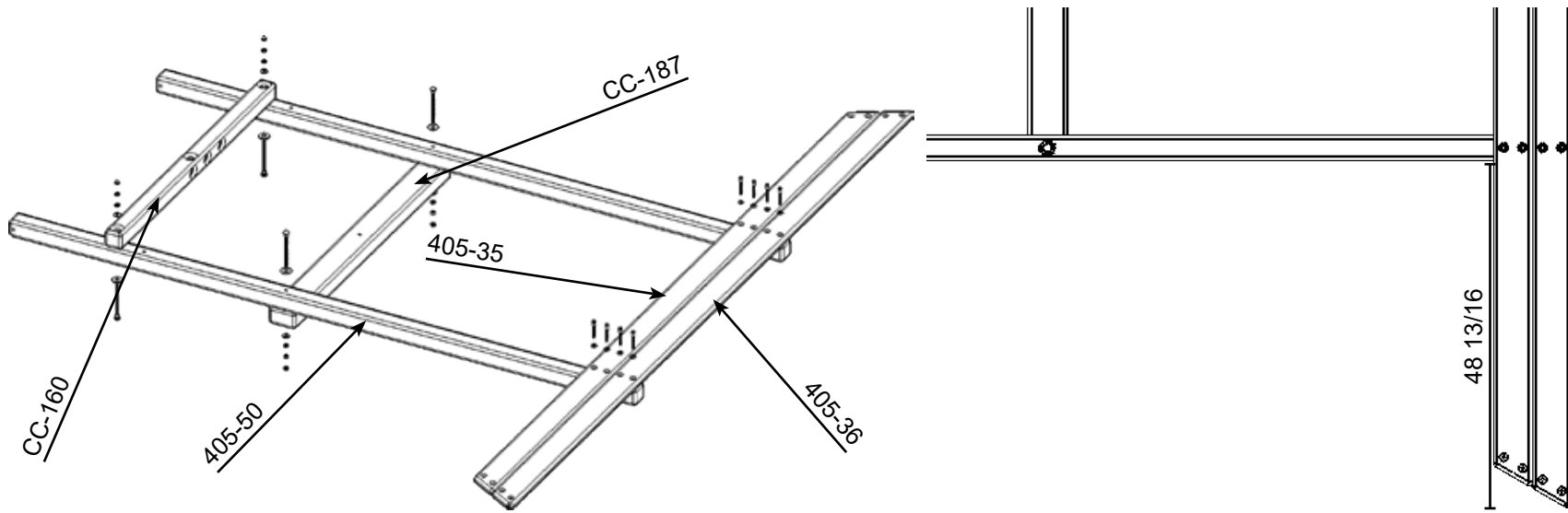

Swingbeam Side Wall

PARTS NEEDED

CC-165- 38 7/8" Center Upright-	(1)
CC-149- 19" Left Gusset-	(1)
CC-148- 19" Right Gusset-	(1)

HARDWARE NEEDED

A-5- 1/2" x 7" Carriage Bolt-	(2)	Q- 3/4" USS Flatwasher-	(2)
P- 1/2" USS Flatwasher-	(2)	M- 1/2" Split Lockwasher-	(2)
E- 1/2" Hex Nut-	(2)	A-2- 1/2" Acorn Nut Plated-	(2)
H- 3/8" x 3 1/2" Hex Lag Screw-	(4)	O- 3/8" USS Flatwasher-	(4)

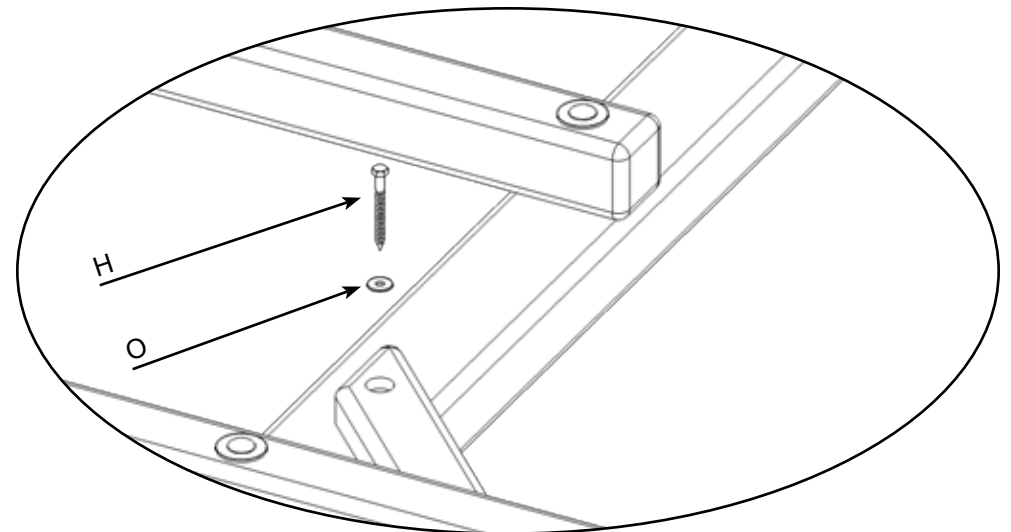
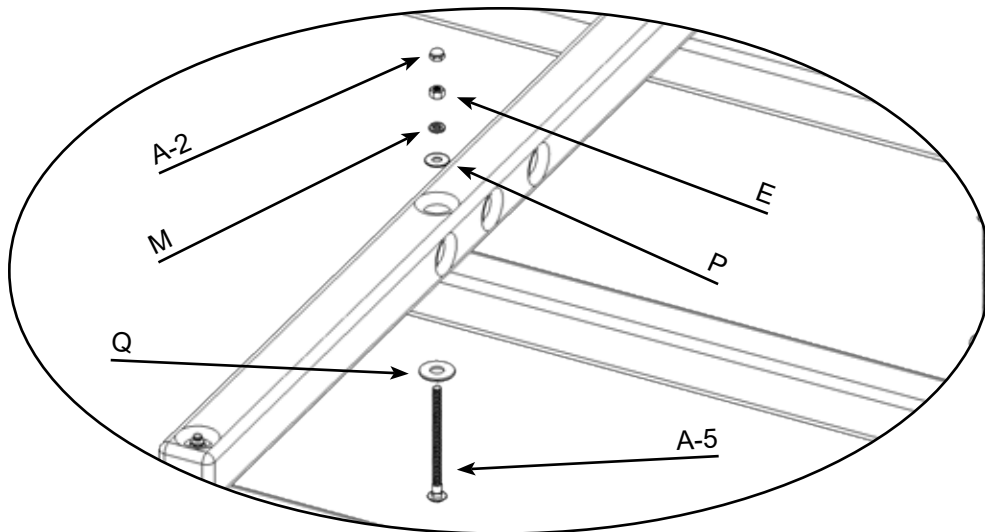
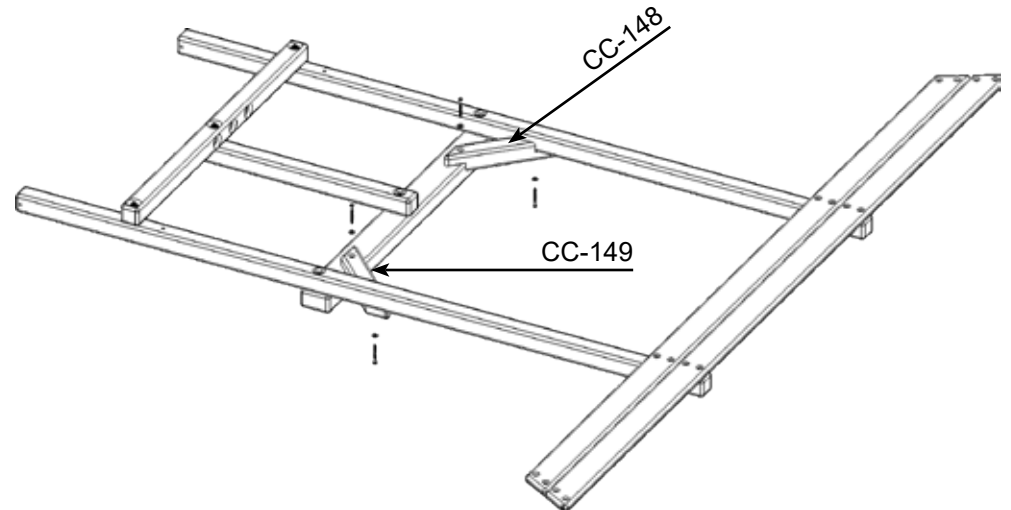
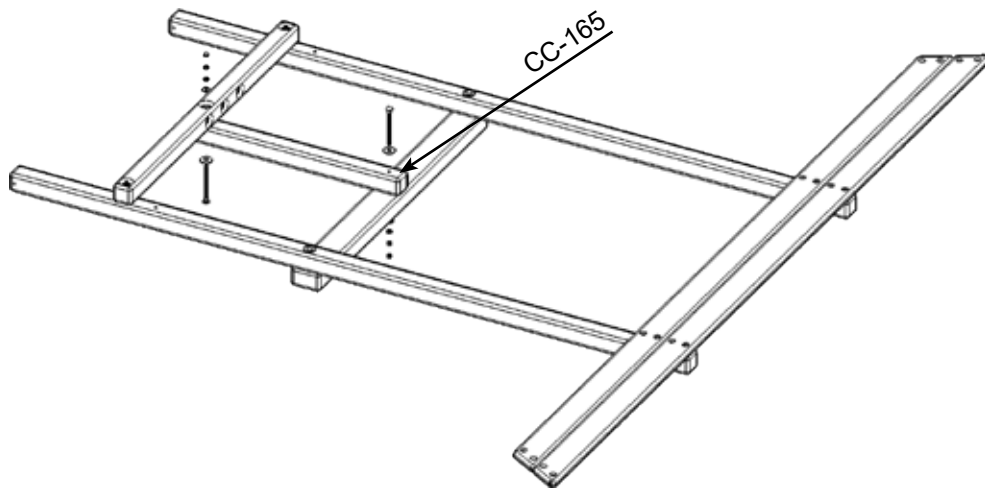

Swingbeam Side Wall

PARTS NEEDED

CC-100- 25" Rail Bottom-

(2)

HARDWARE NEEDED

A-9- 1/4" x 2" Hex Lag Screw-

(4)

N- 1/4" USS Flatwasher-

(4)

CC-100'S SIT 1/2" ABOVE THE TOP OF THE GUSSETS

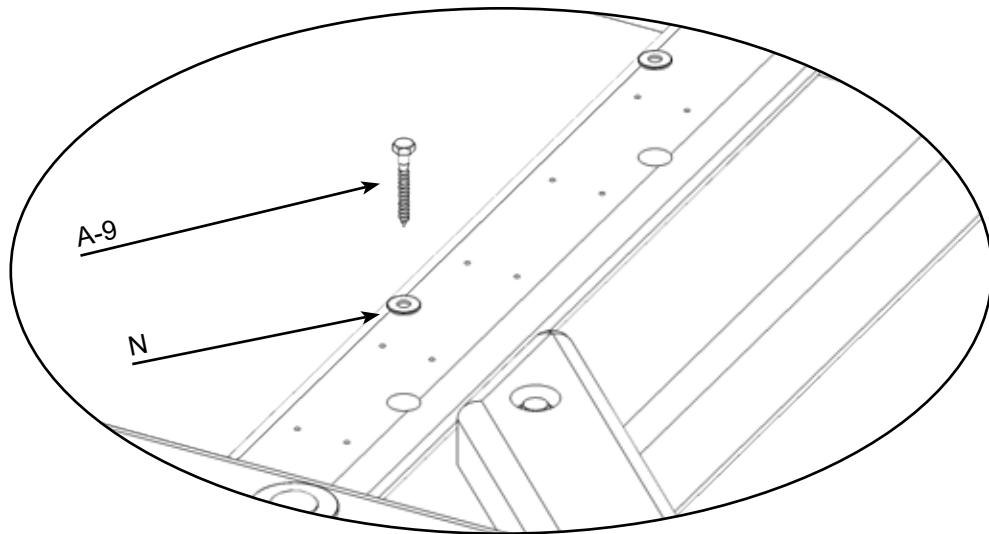
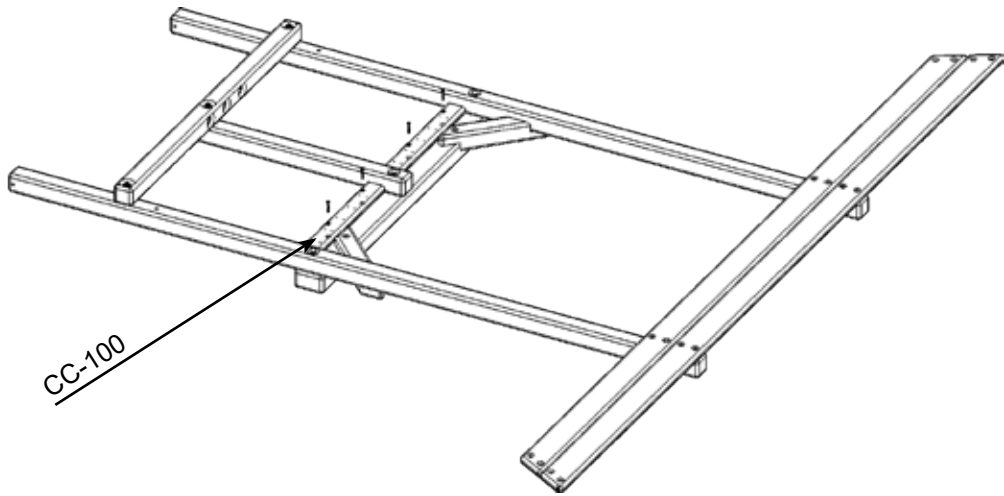

REMOVE THE 3 CARRIAGE BOLTS SEEN BELOW FOR THE NEXT STEP

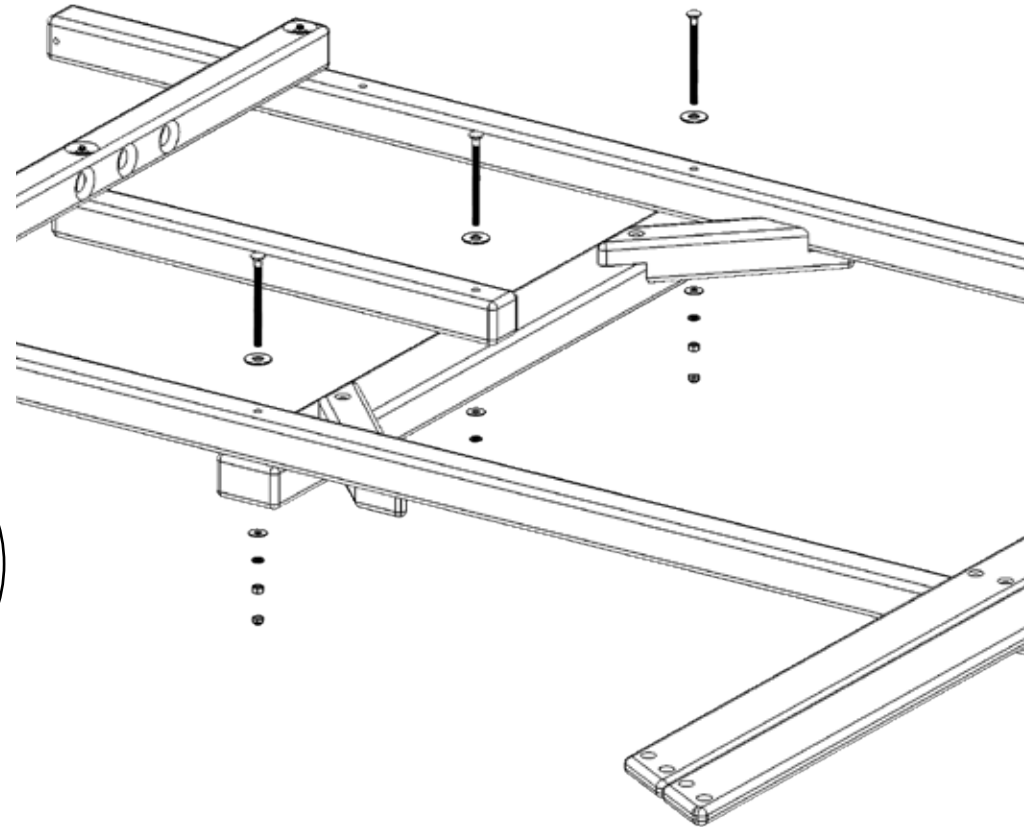

Swingbeam Side Wall

PARTS NEEDED

405-34- 75" Support Wing Mainbeam- (1)

A-2- 1/2" Acorn Nut Plated-
 M- 1/2" Split Lockwasher-
 Q- 3/4" USS Flatwasher-

Swingbeam Side Wall Complete

HARDWARE NEEDED

(3) E- 1/2" Hex Nut- (3)
 (3) P- 1/2" USS Flatwasher- (3)
 (3) A-8- 1/2" x 8" Carriage Bolt- (3)

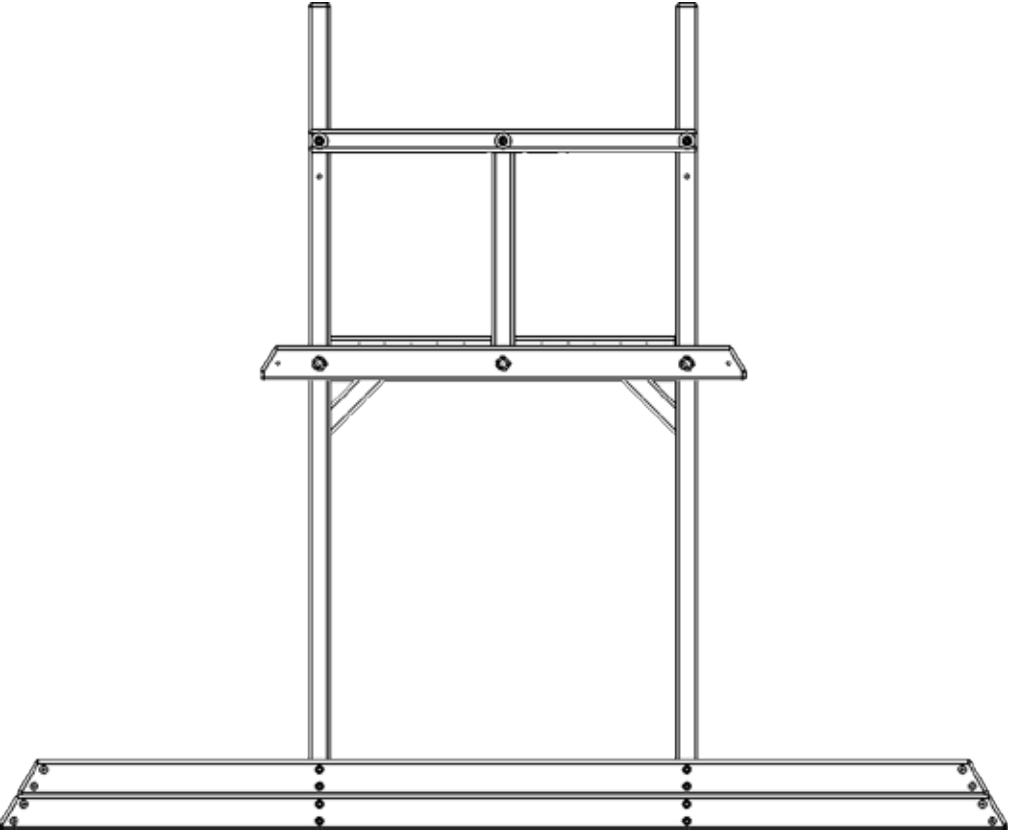
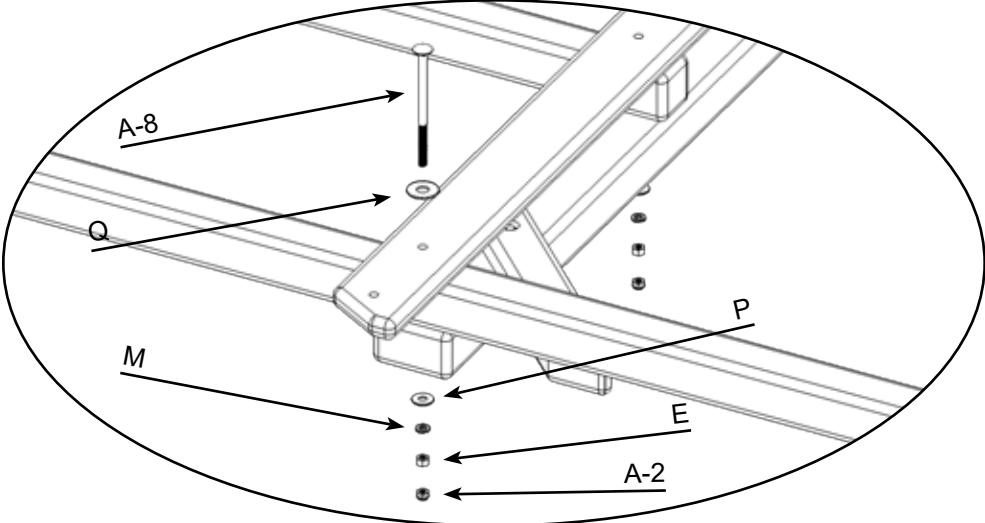
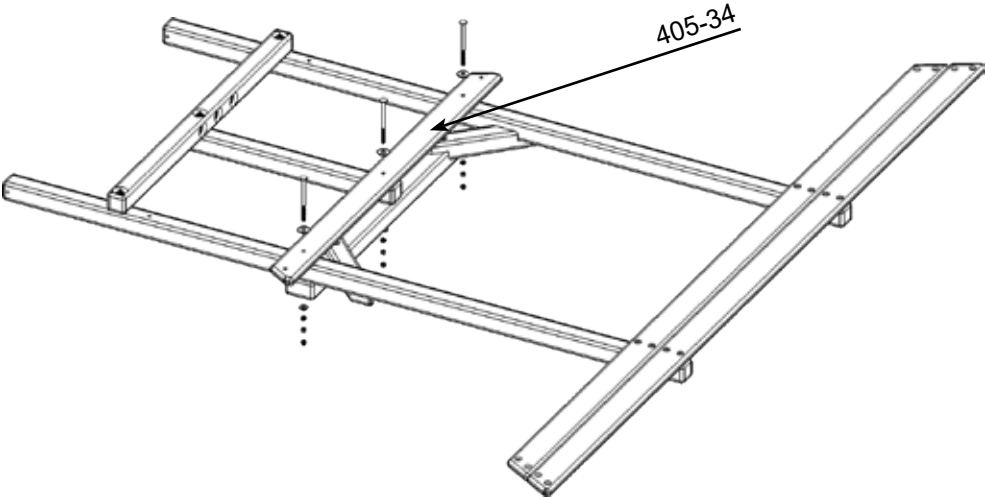

Trapeze Side Wall

PARTS NEEDED

CC-166- 104" Trapeze Arm-	(1)
CC-187- 60 1/4" Mainbeam-	(1)
405-50- 128" Corner Post-	(2)
CC-125- 60 1/4" 4- Hole Facia-	(2)

HARDWARE NEEDED

A-5- 1/2" x 7" Carriage Bolt-	(4)	Q- 3/4" USS Flatwasher-	(4)
P- 1/2" USS Flatwasher-	(4)	M- 1/2" Split Lockwasher-	(4)
E- 1/2" Hex Nut-	(4)	A-2- 1/2" Acorn Nut Plated-	(4)
H- 3/8" x 3 1/2" Hex Lag Screw-	(8)	O- 3/8" USS Flatwasher-	(8)

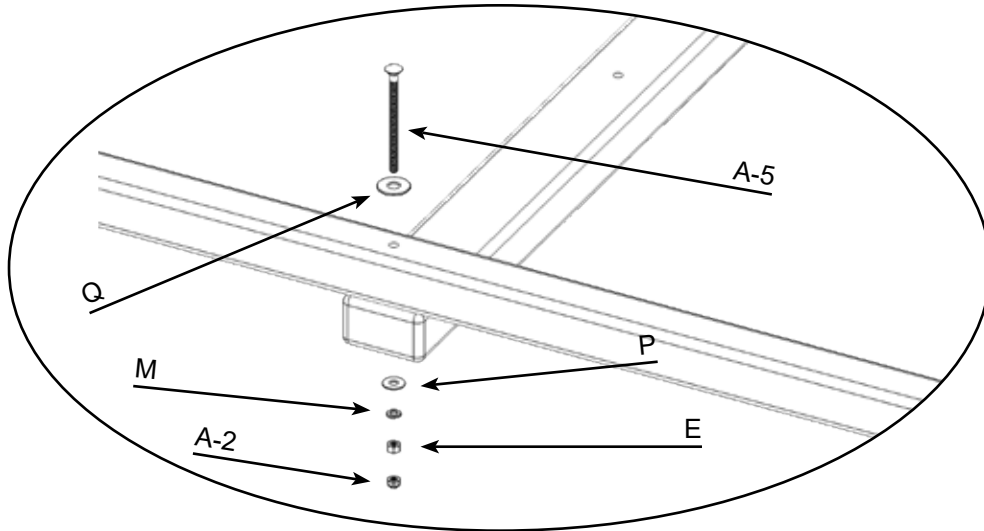
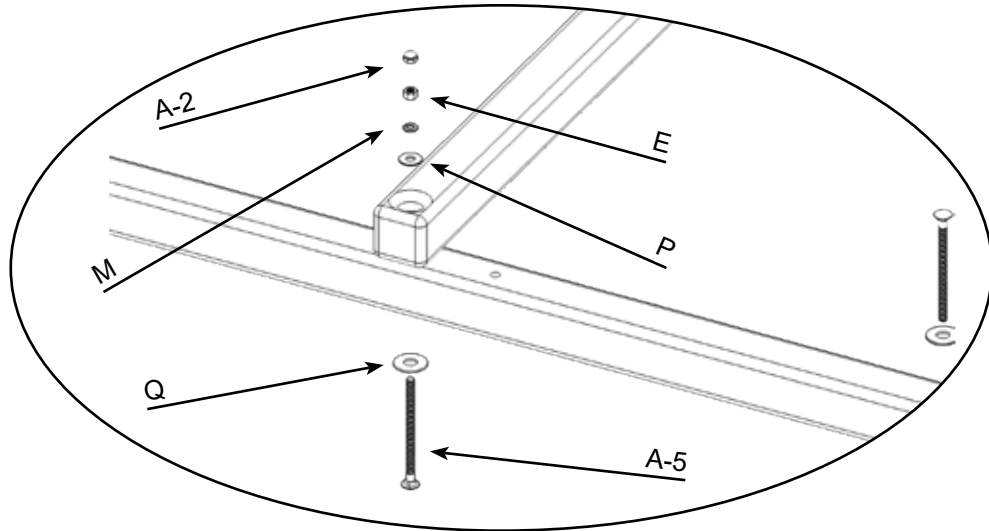
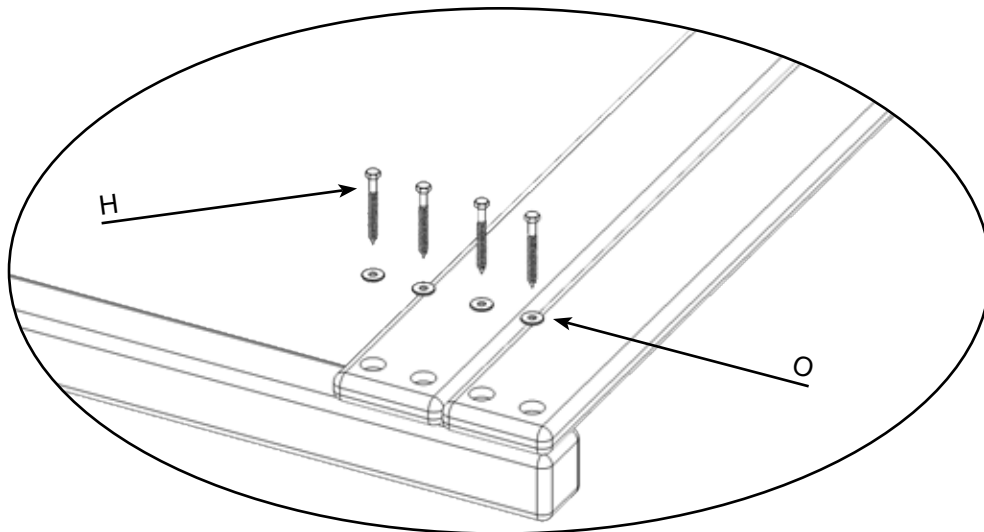
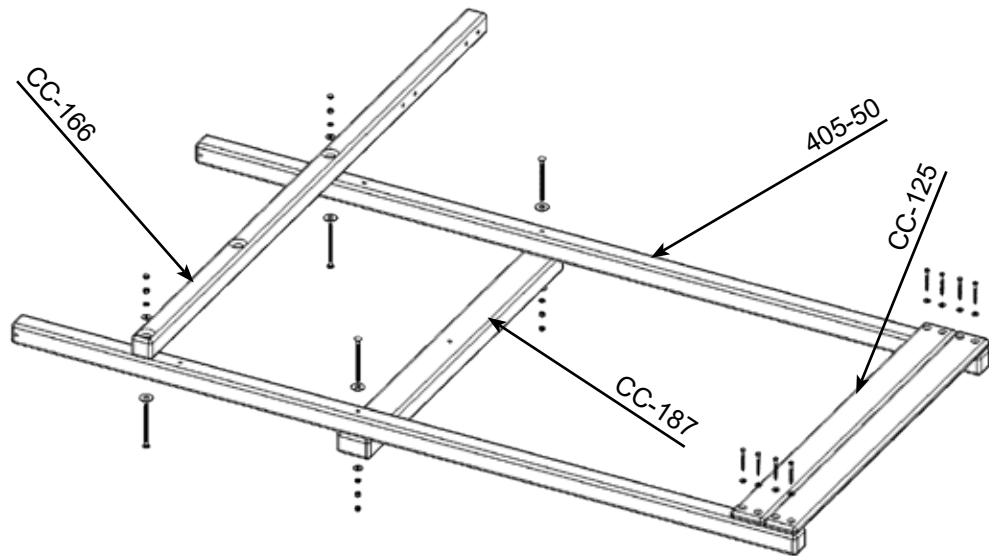

Trapeze Side Wall

PARTS NEEDED

CC-165- 38 7/8" Center Upright- (1)
 CC-149- 19" Left Gusset- (1)
 CC-148- 19" Left Gusset- (1)

A-5- 1/2" x 7" Carriage Bolt- (2)
 P- 1/2" USS Flatwasher- (2)
 E- 1/2" Hex Nut- (2)
 H- 3/8" x 3 1/2" Hex Lag Screw- (4)

HARDWARE NEEDED

Q- 3/4" USS Flatwasher- (2)
 M- 1/2" Split Lockwasher- (2)
 A-2- 1/2" Acorn Nut Plated- (2)
 O- 3/8" USS Flatwasher- (4)

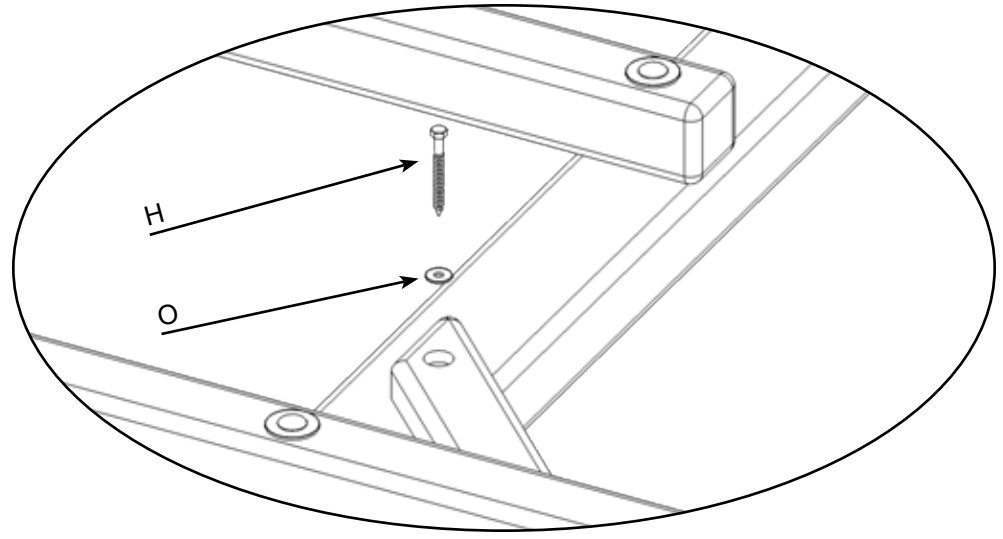
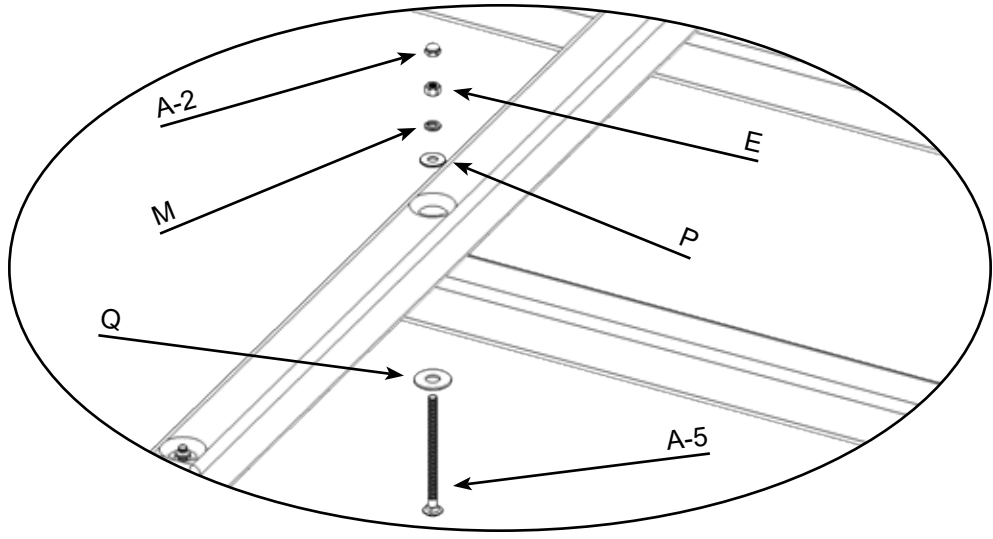
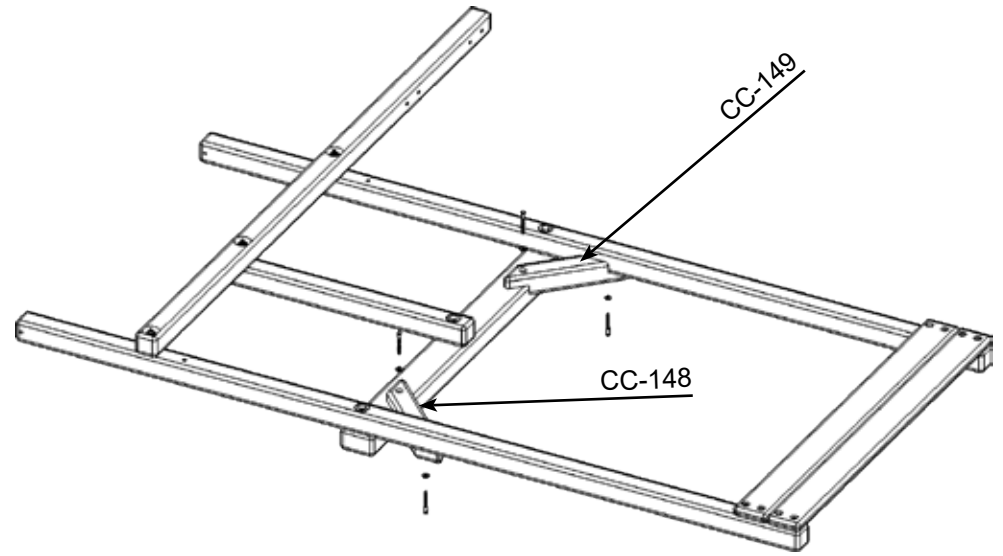
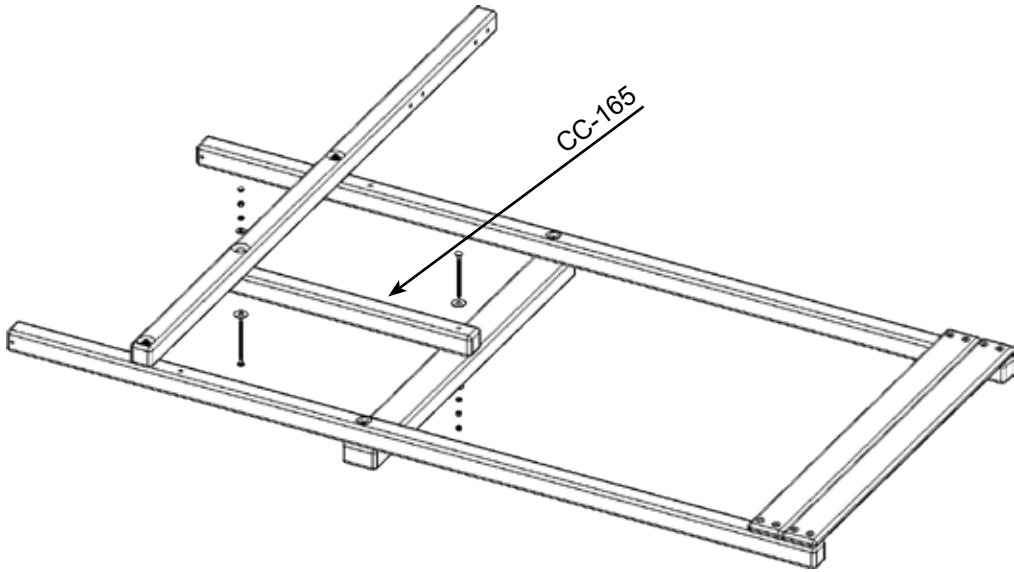

Trapeze Side Wall

PARTS NEEDED

405-I- Ductile Iron Swing Hanger- (2)

A-8- 3/8" x 5" Hex Bolt- (4)

O- 3/8" USS Flatwasher- (4)

A-10- 3/8" Nylon Insert Locknut- (4)

HARDWARE NEEDED

A-12- 3/8" Bolt Cup- (4)

A-11- 3/8" Split Lockwasher- (4)

A-1- 3/8" Acorn Nut Plated- (4)

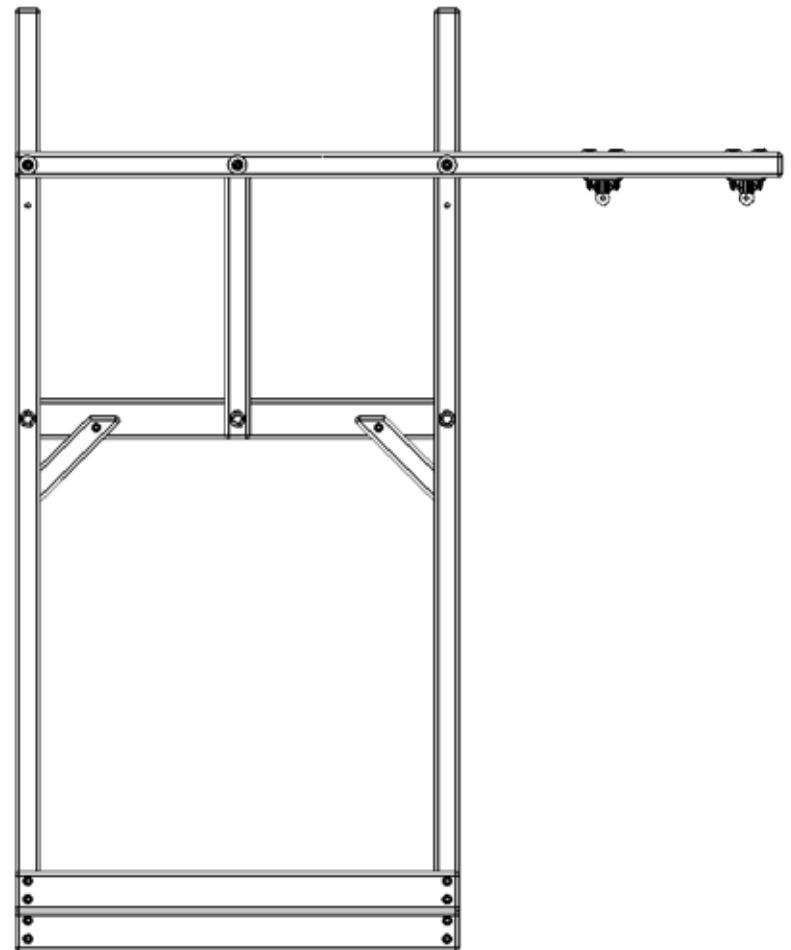
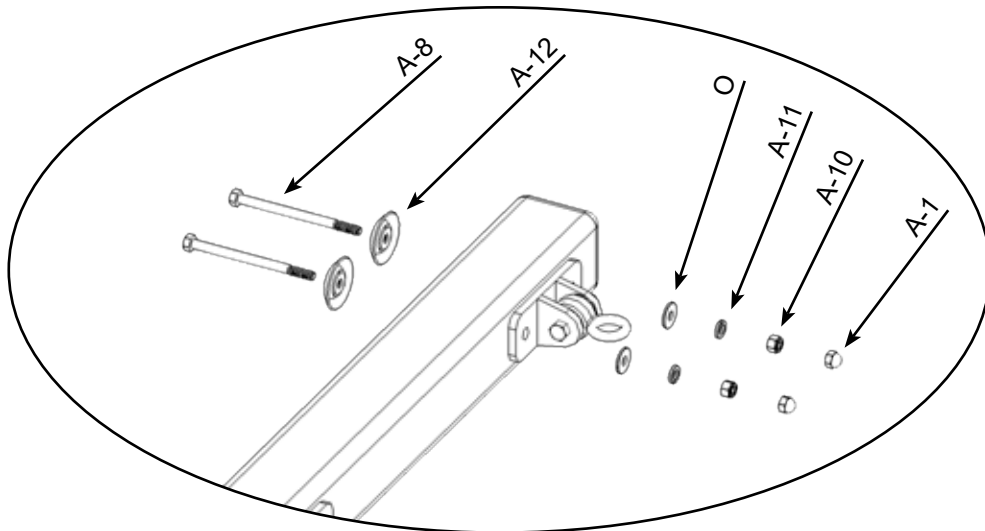
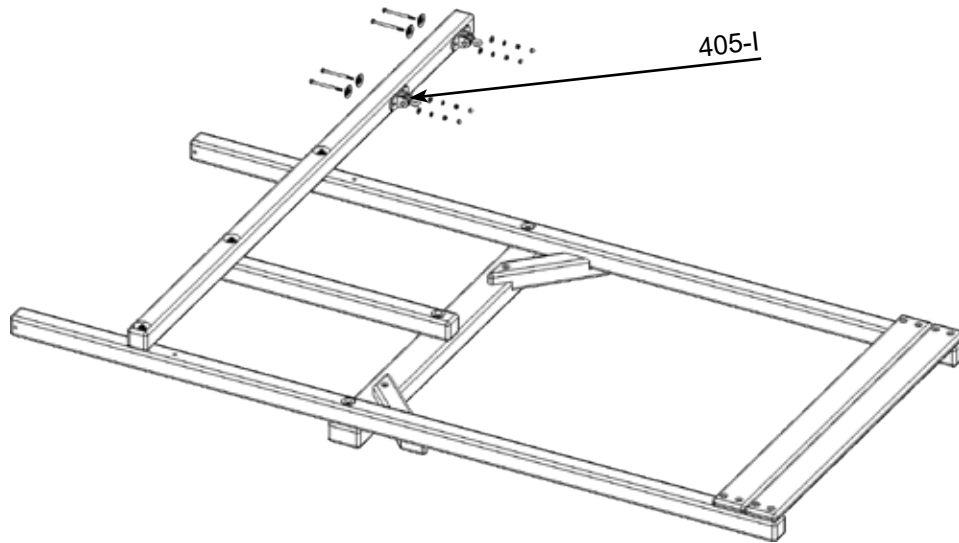

Main Assembly

PARTS NEEDED

CC-127- 60 3/4" 4- Hole Facia- (4)
Deck Assemblies- (2)

HARDWARE NEEDED

O- 3/8" USS Flatwasher- (16)
H- 3/8" x 3 1/2" Hex Lag Screw- (16)
G- 1/4" x 4 1/2" Hex Lag Screw- (8)
N- 1/4" USS Flatwasher- (8)

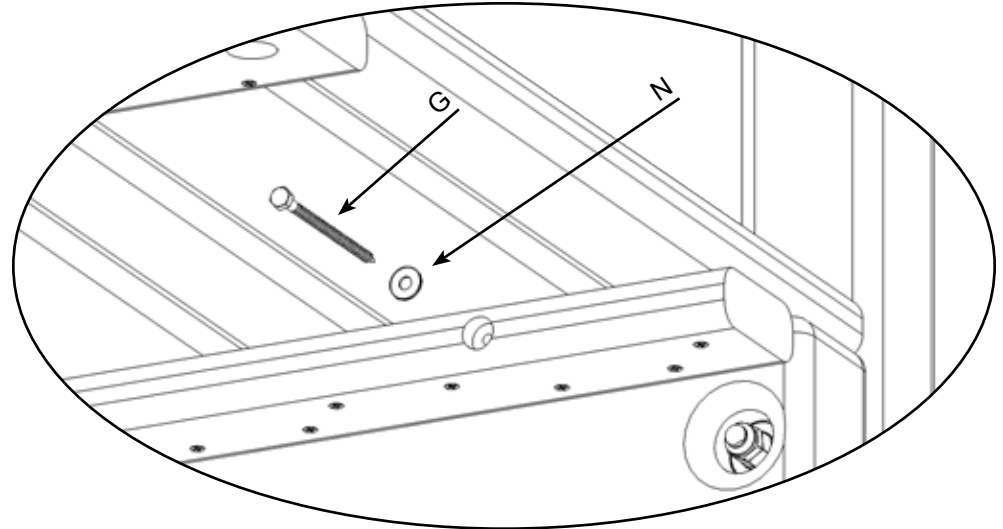
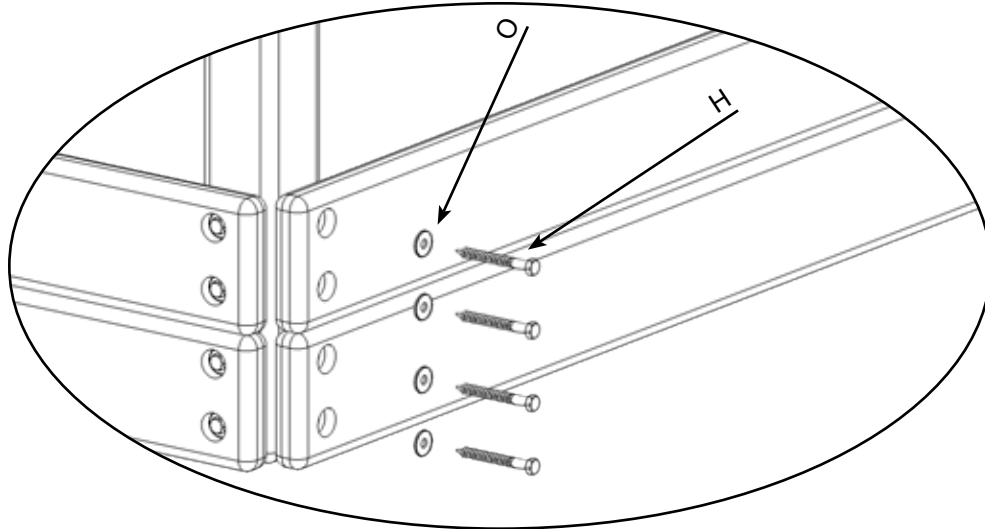
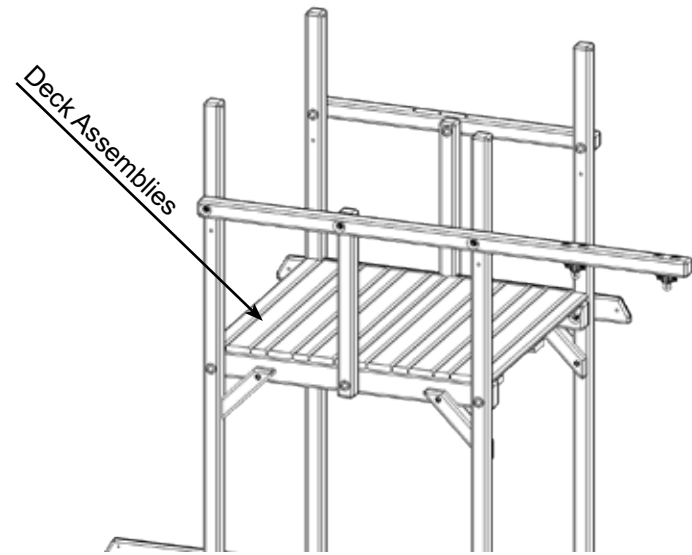
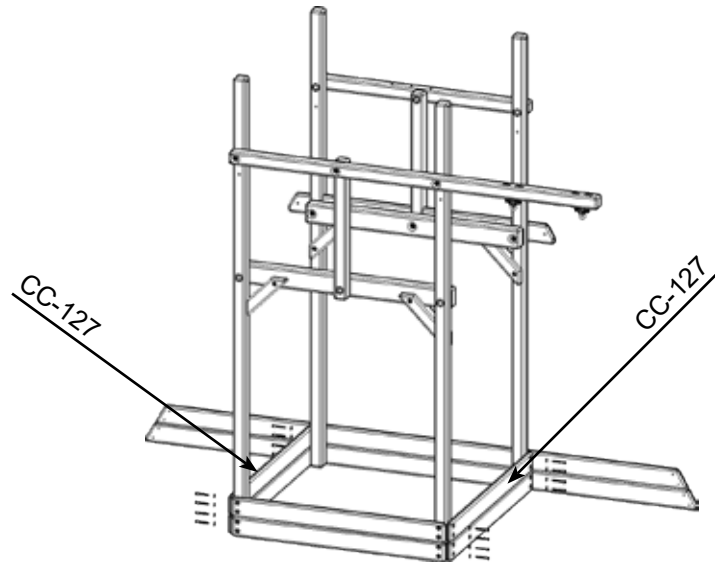

Main Assembly

PARTS NEEDED

CC-129- 60 3/4" 8- Hole Facia- (2)
CC-128- 60 3/4" 6-Hole Facia- (2)

HARDWARE NEEDED

H- 3/8" x 3 1/2" Hex Lag Screw- (16)
O- 3/8" USS Flatwasher- (16)
N- 1/4" USS Flatwasher- (8)
G- 1/4" x 4 1/2" Hex Lag Screw- (8)

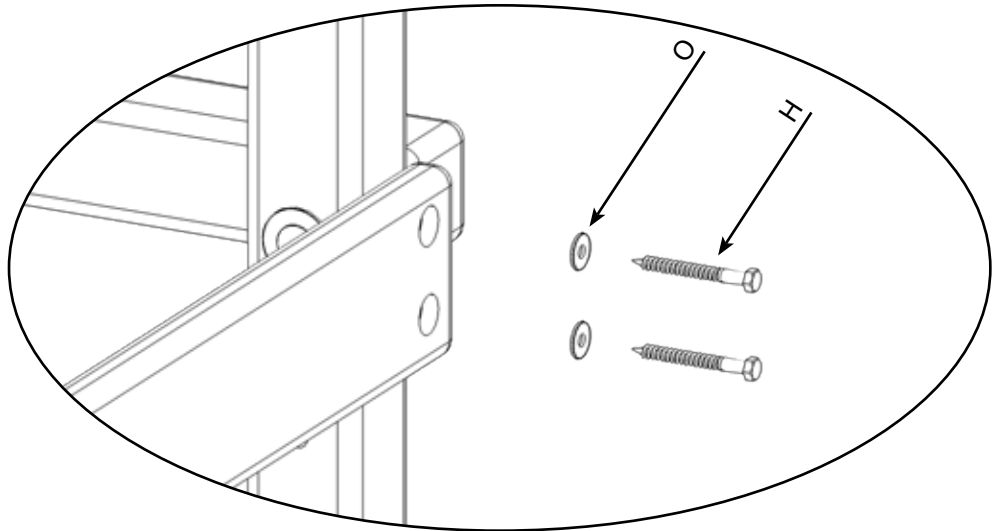
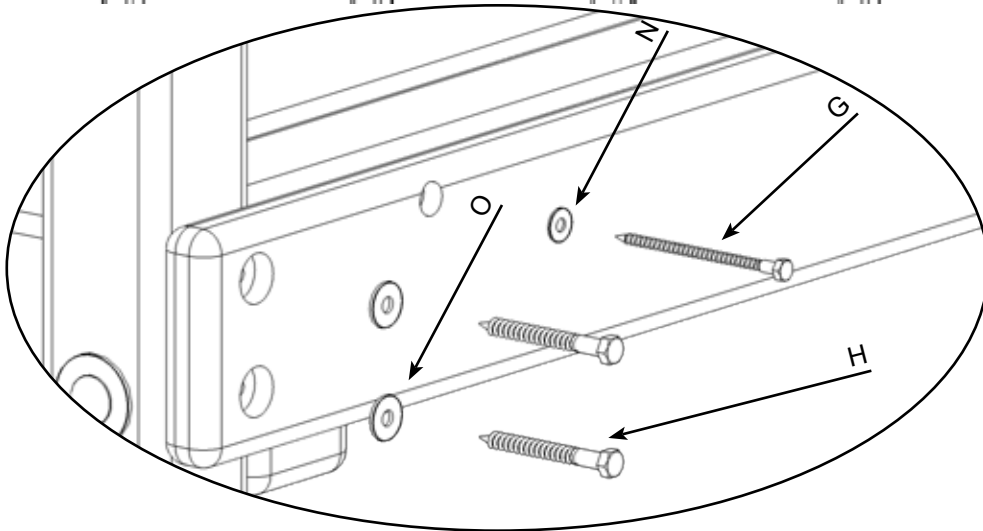
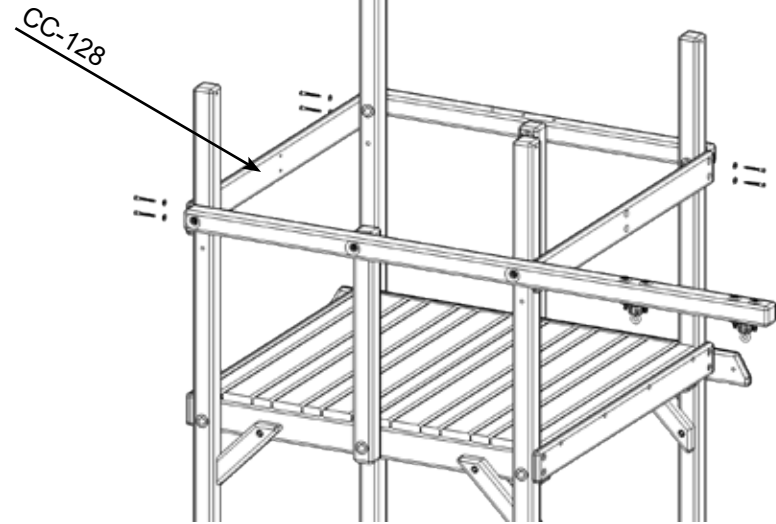
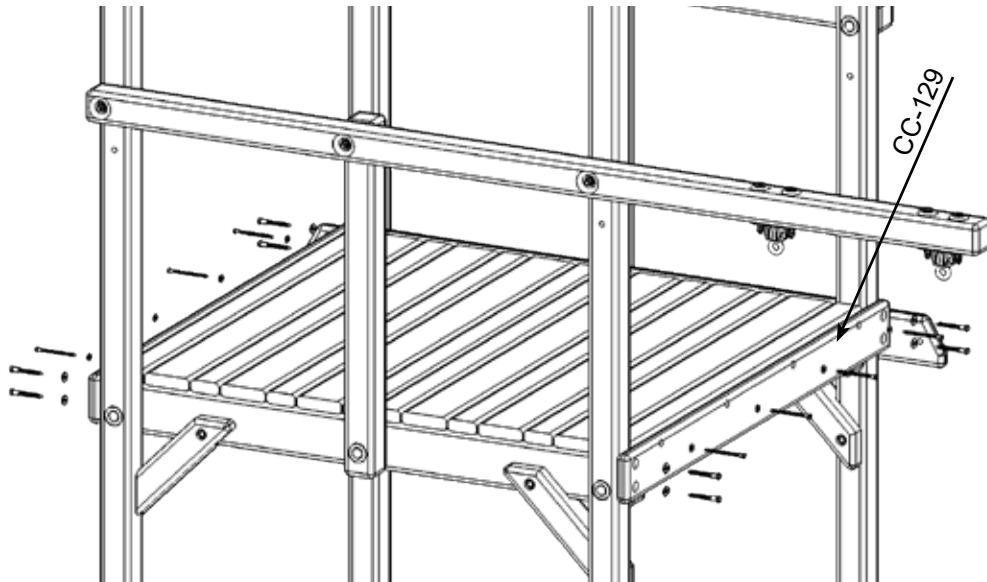

Main Assembly

PARTS NEEDED

CC-164- 32 1/8" Center Post- (2)
CC-142- 25" Entrapment Block- (2)

HARDWARE NEEDED

O- 3/8" USS Flatwasher- (10)
H- 3/8" x 3 1/2" Hex Lag Screw- (4)
I- 3/8" x 5" Hex Lag Screw- (6)

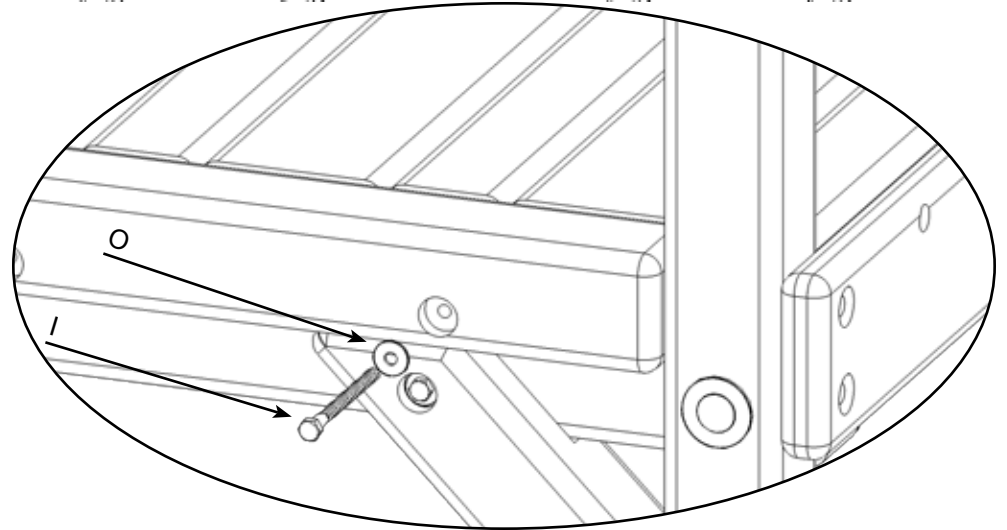
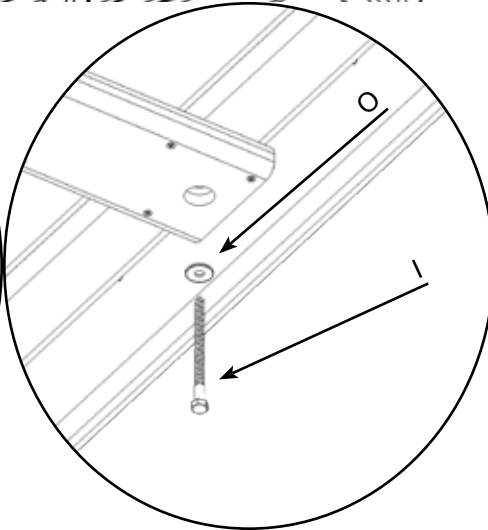
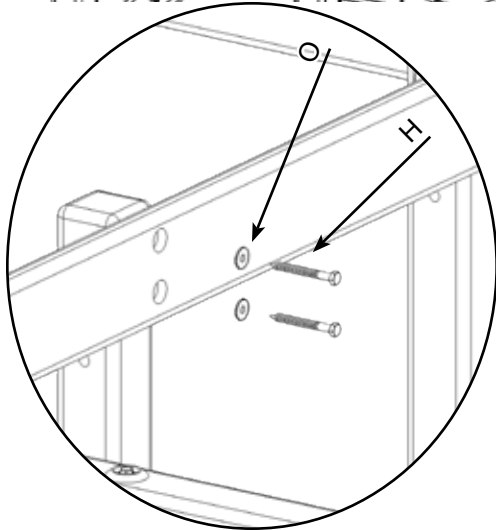
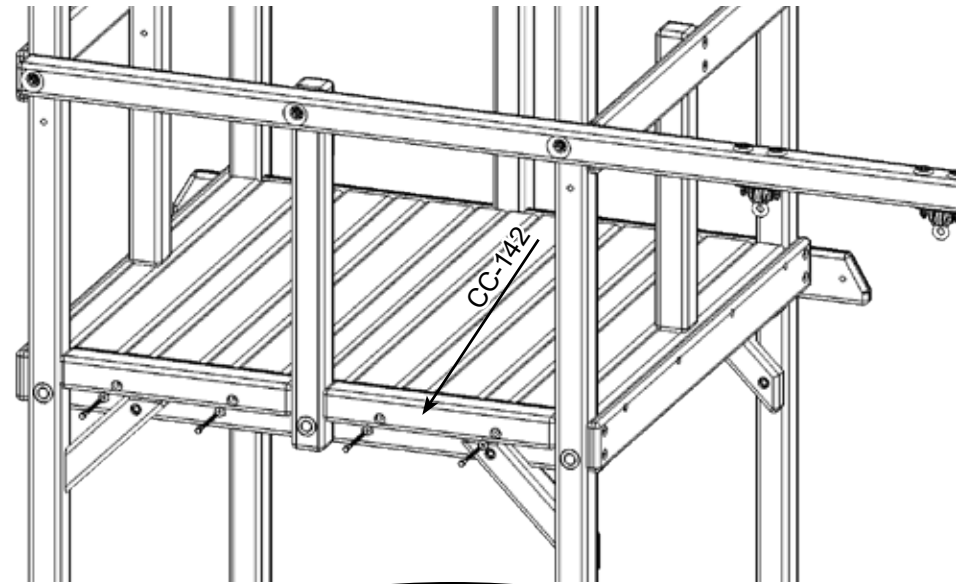
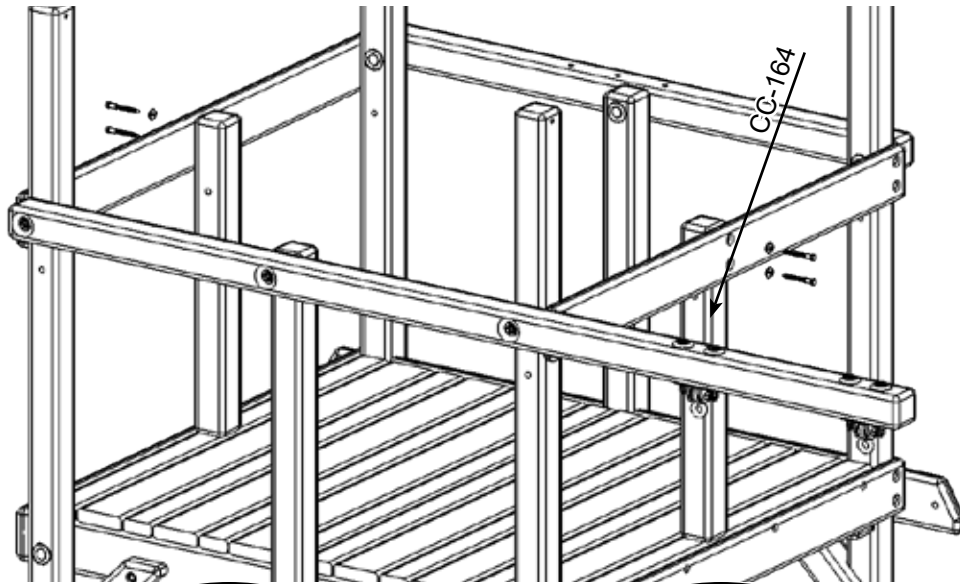

Main Assembly

PARTS NEEDED

- Rockwall Assembly- (1)
- 405-44- 85 15/16" Wing Support Leg- (2)
- 405A- Fort Ladder Bracket- (1)

HARDWARE NEEDED

- | | |
|--------------------------------------|---------------------------------------|
| O- 3/8" USS Flatwasher- (12) | I- 3/8" x 5" Hex Lag Screw- (2) |
| H- 3/8" x 3 1/2" Hex Lag Screw- (10) | A-4- 1/2" x 4 1/2" Carriage Bolt- (2) |
| Q- 3/4" USS Flatwasher- (2) | P- 1/2" USS Flatwasher- (2) |
| M- 1/2" Split Lockwasher- (2) | E- 1/2" Hex Nut- (2) |
| A-2- 1/2" Acorn Nut Plated- (2) | |

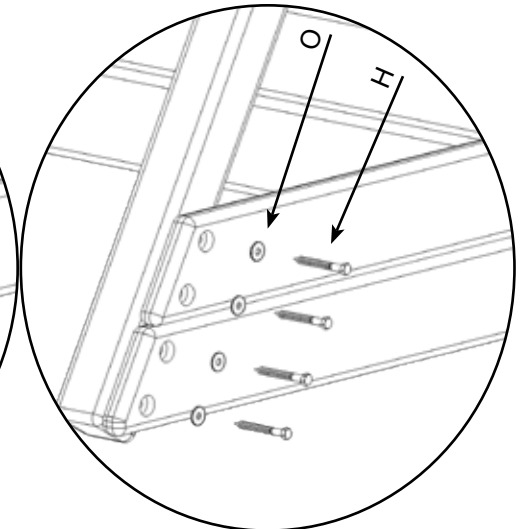
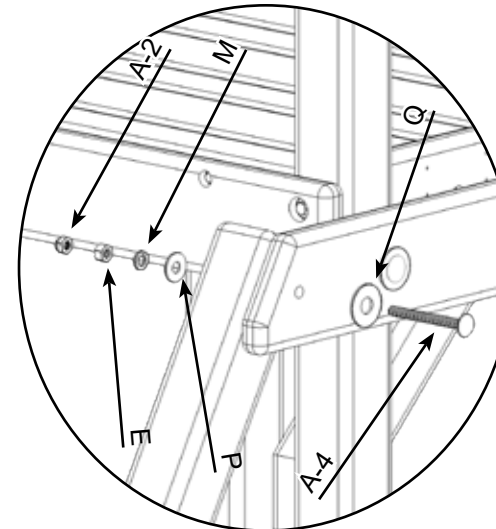
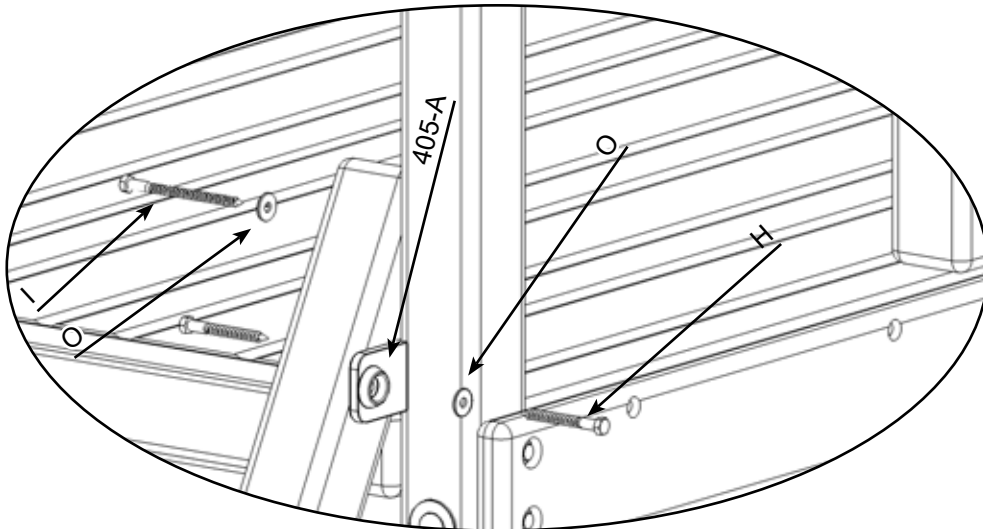
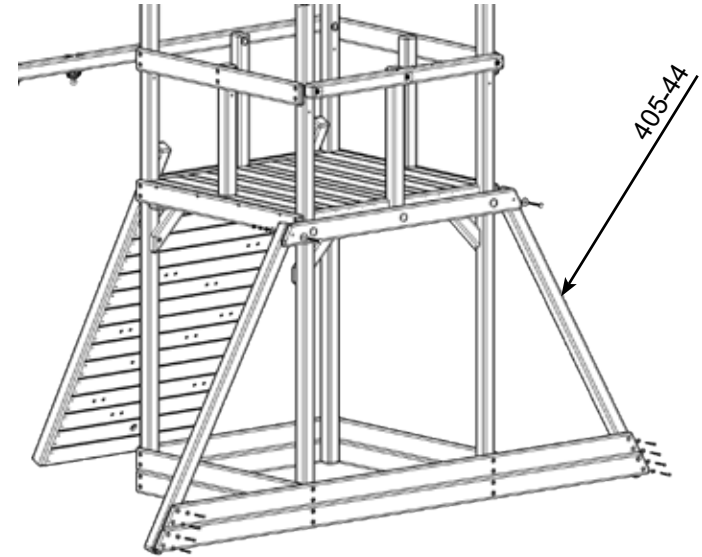
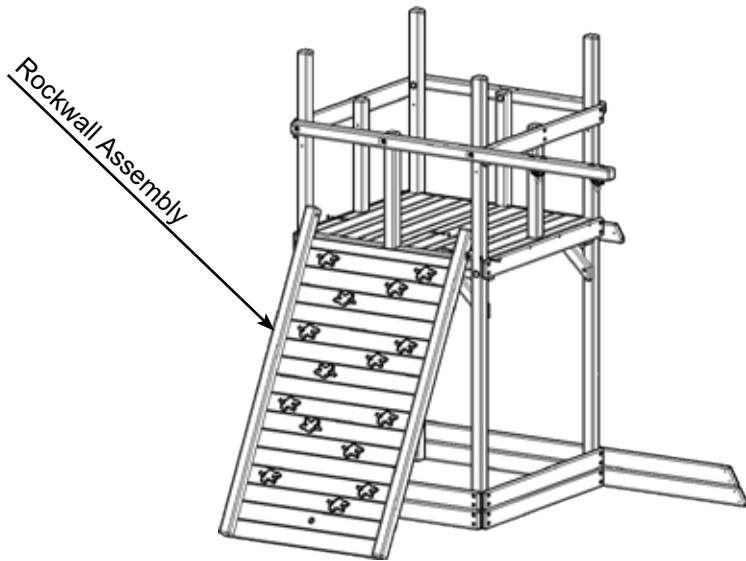

Main Assembly

PARTS NEEDED

Ladder Assembly-	(1)
CC-148- 19" Right Gusset-	(1)
405-A- Fort Ladder Bracket-	(1)

HARDWARE NEEDED

O- 3/8" USS Flatwasher-	(6)
I- 3/8" x 5" Hex Lag Screw-	(2)
H- 3/8" x 3 1/2" Hex Lag Screw-	(4)

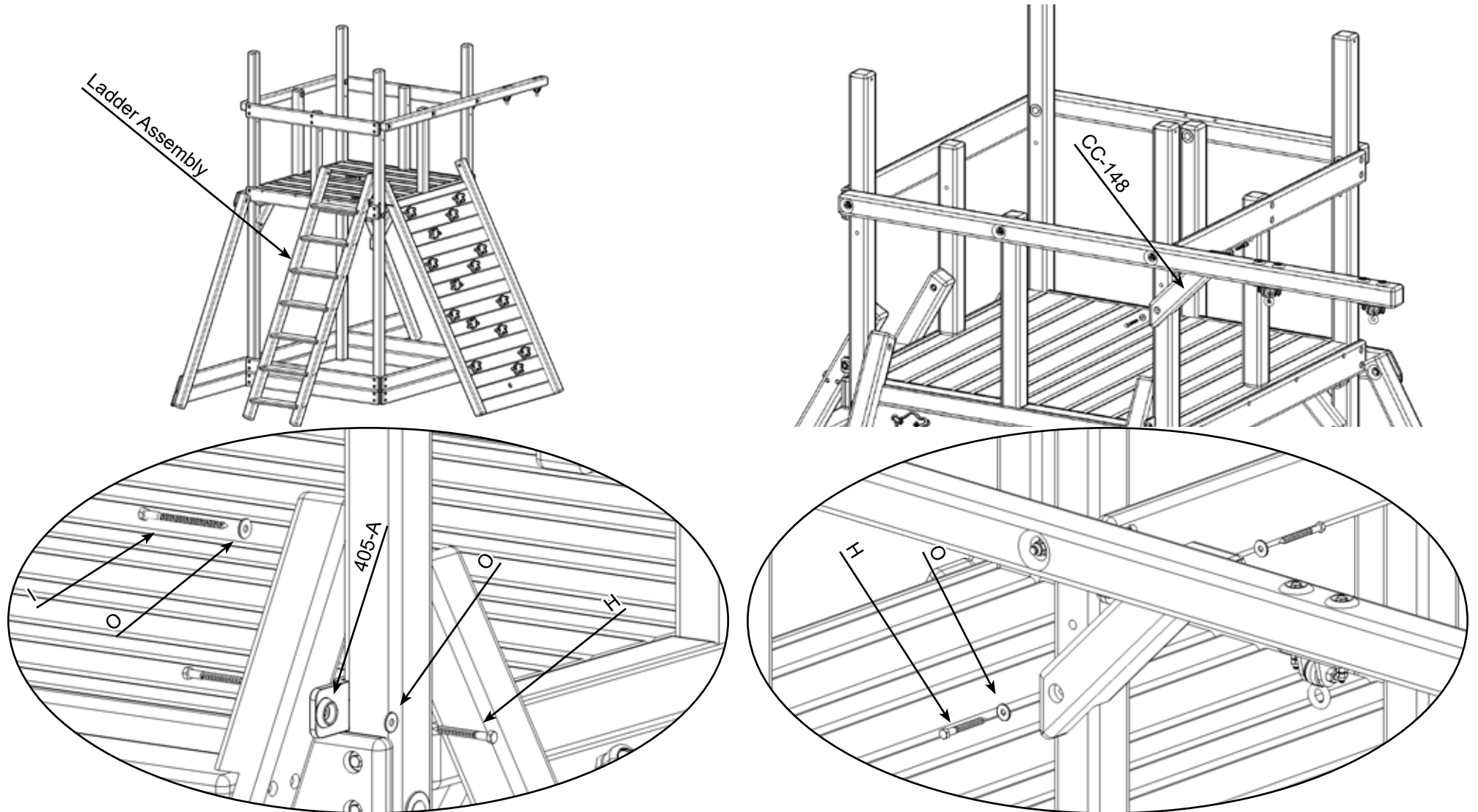

Main Assembly

PARTS NEEDED

CC-143- 11" Rope Block- (1)
405-F- 16' Yellow Rope- (1)

HARDWARE NEEDED

I- 3/8" x 5" Hex Lag Screw- (2)
O- 3/8" USS Flatwasher- (2)

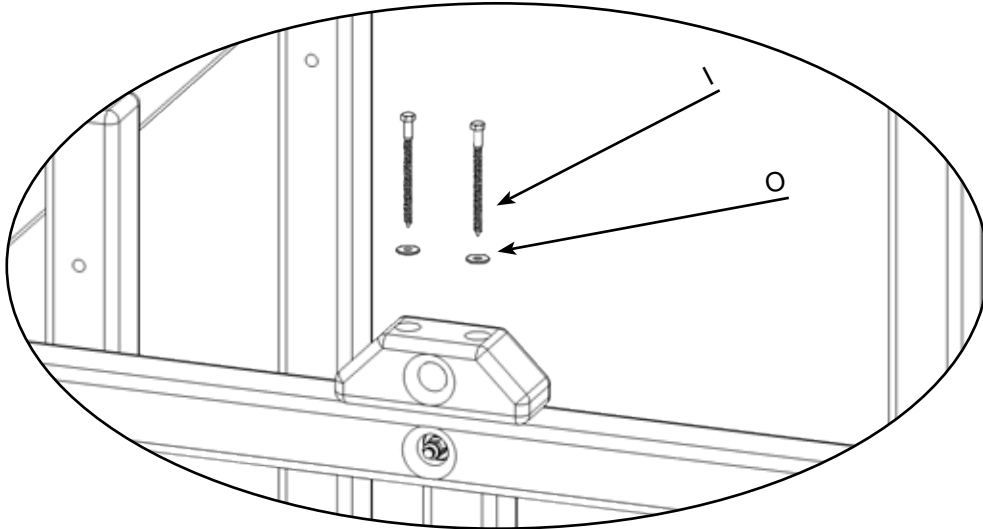
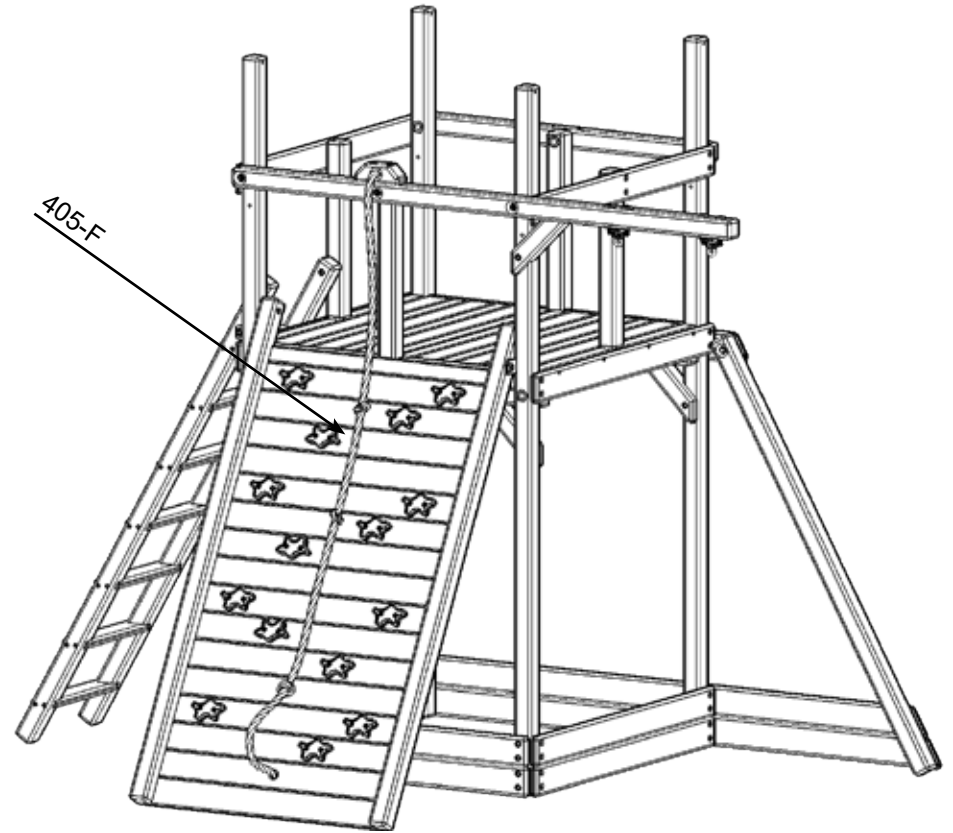
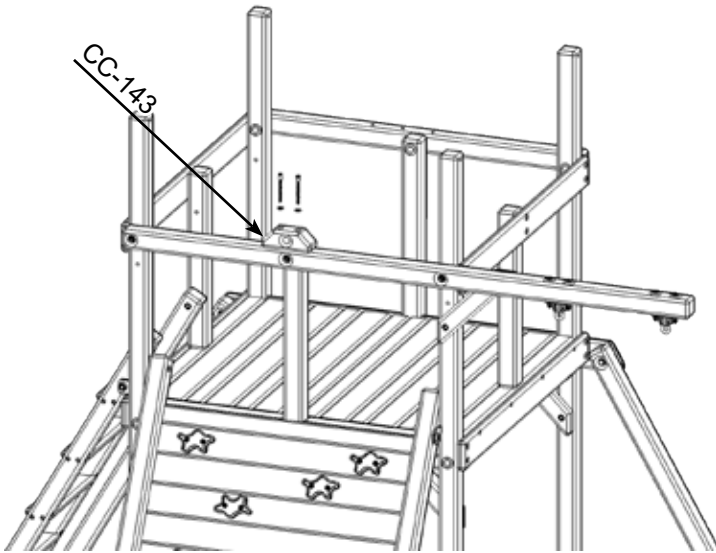

SLIDE 405-F THROUGH CC-143 AND TIE A KNOT HOLDING IT IN PLACE. WORK YOUR WAY DOWN TYING A KNOT EVERY 2 TO 3 FEET UNTIL YOU STRING THE ROPE THROUGH CC-087 AND TIE A KNOT SECURING THE ROPE TO THE ROCKWALL.

Main Assembly

PARTS NEEDED

CC-107- 48 1/8" Wood Roof Support- (4)
 CC-053- 9 9/16" Wood Roof Peak- (2)

A-3- 3/8" x 5" Carriage Bolt- (4)
 O- 3/8" USS Flatwasher- (4)
 A-7- 3/8" Hex Nut- (4)
 D- 2 1/2" Coated Deck Screw- (4)

HARDWARE NEEDED

P- 1/2" USS Flatwasher- (4)
 A-11- 3/8" Split Lockwasher- (4)
 A-1- 3/8" Acorn Nut Plated- (4)
 C- 2" Coated Deck Screw- (8)

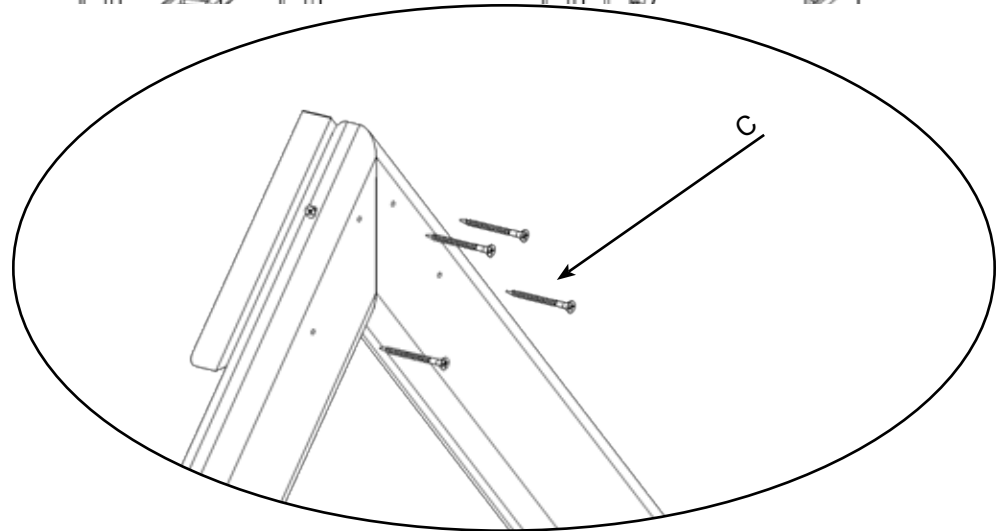
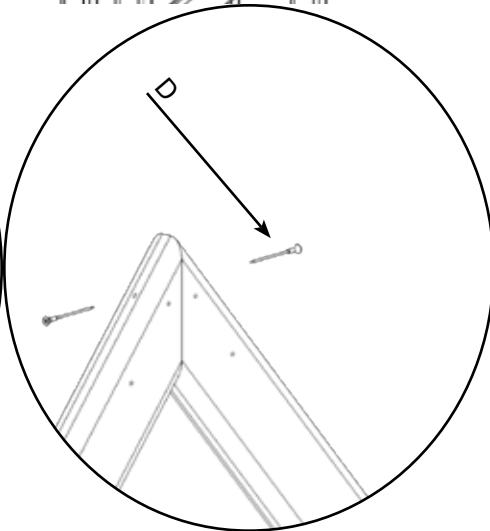
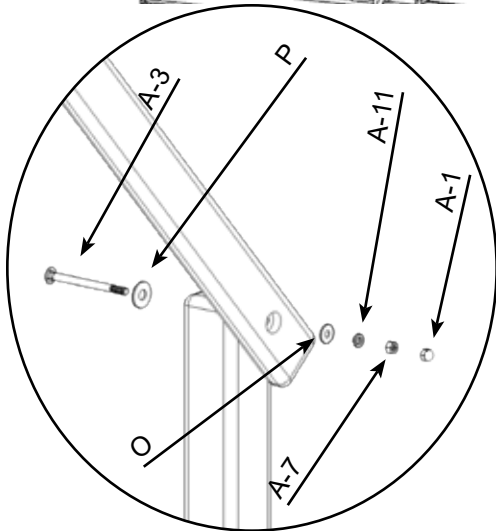
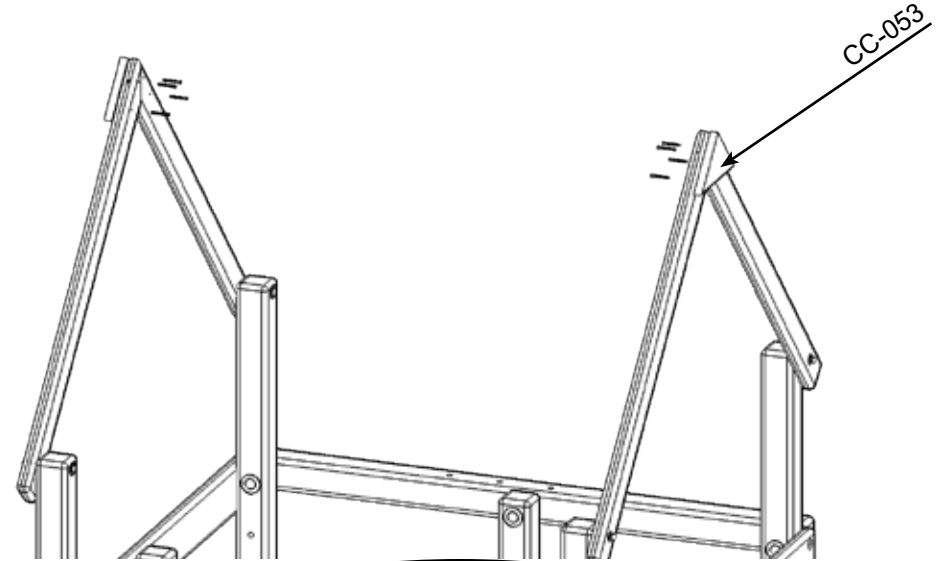
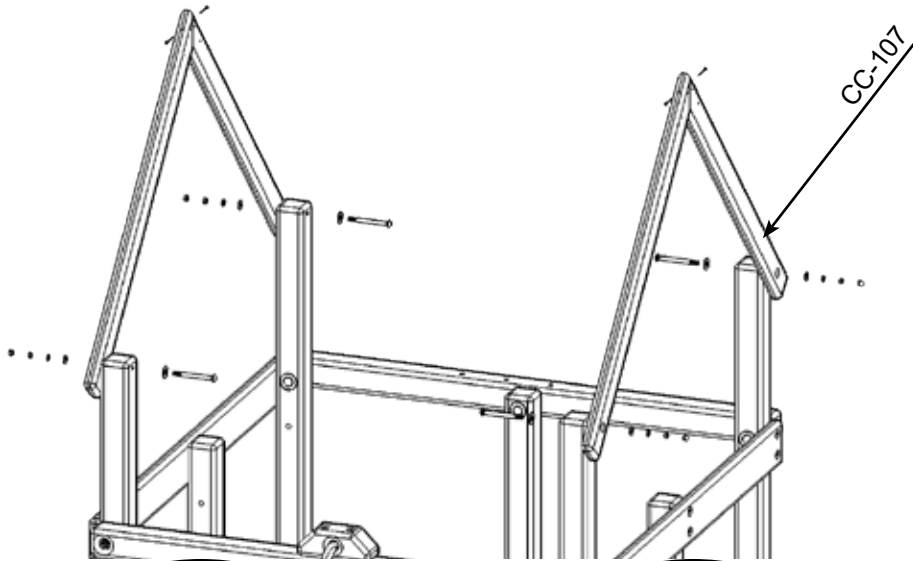

Main Assembly

PARTS NEEDED

CC-195- 67 1/2" Wood Roof Board- (8)
CC-097- 24 1/2" Wood Roof Support- (2)

HARDWARE NEEDED

B- 1 1/2" Coated Deck Screw- (40)

CC-195'S OVERHANGE SUPPORTS BY 2 1/4"

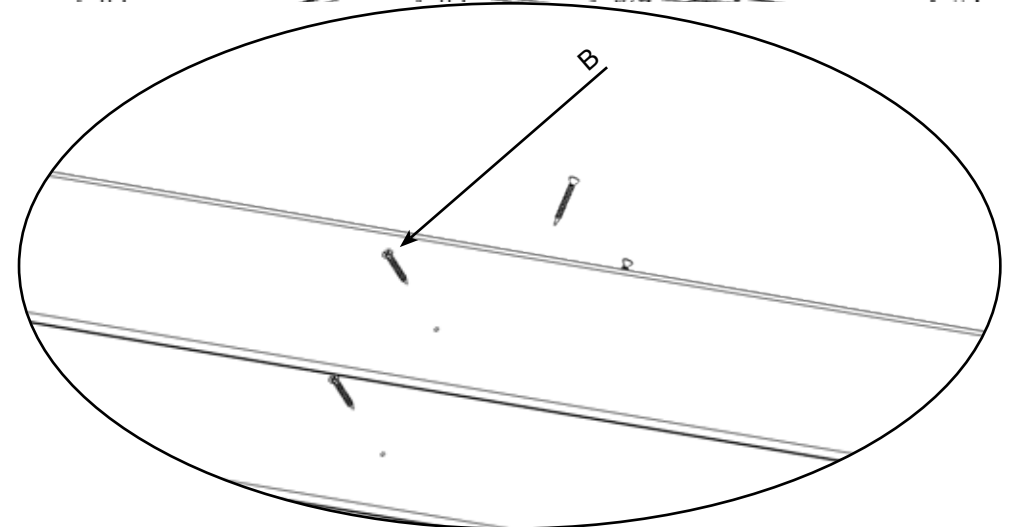
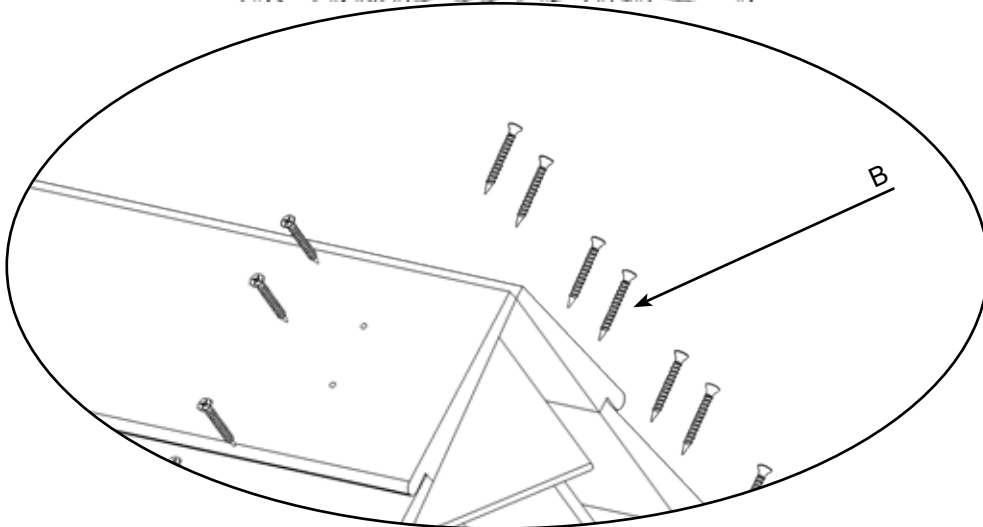
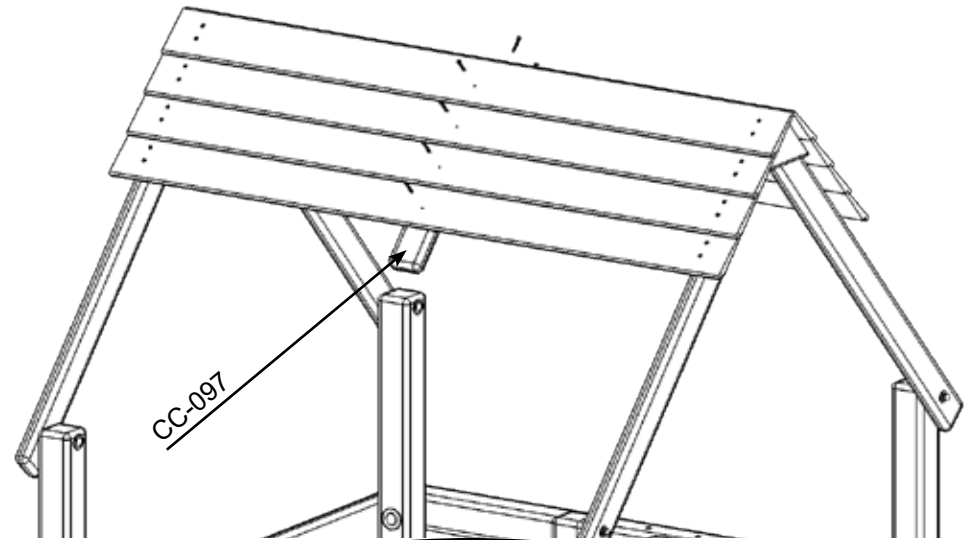
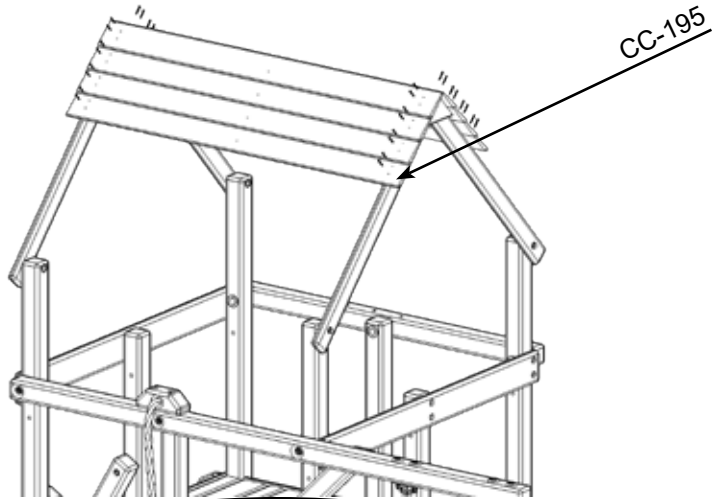

Main Assembly

PARTS NEEDED

CC-195- 67 1/2" Wood Roof Board- (10)
CC-098- 20" Wood Roof Support- (2)

HARDWARE NEEDED

B- 1 1/2" Coated Deck Screw- (50)

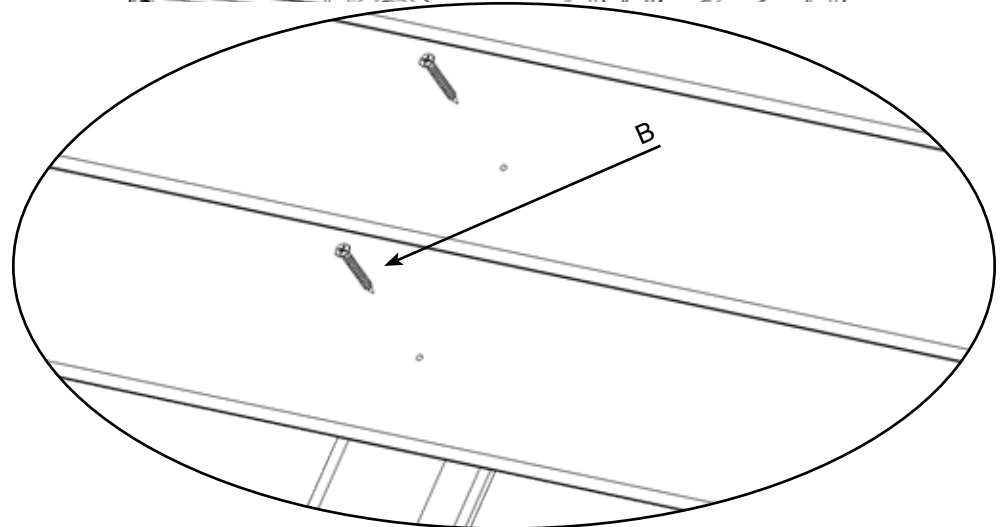
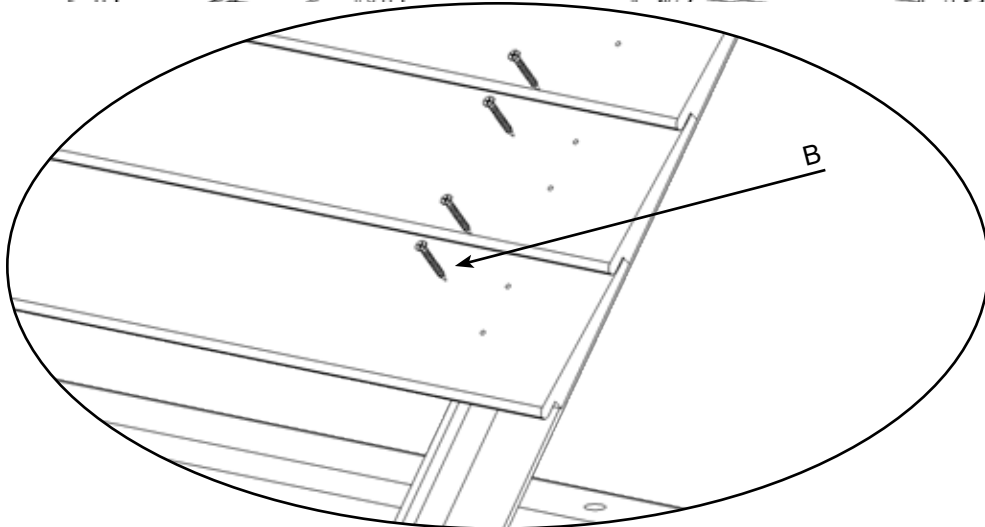
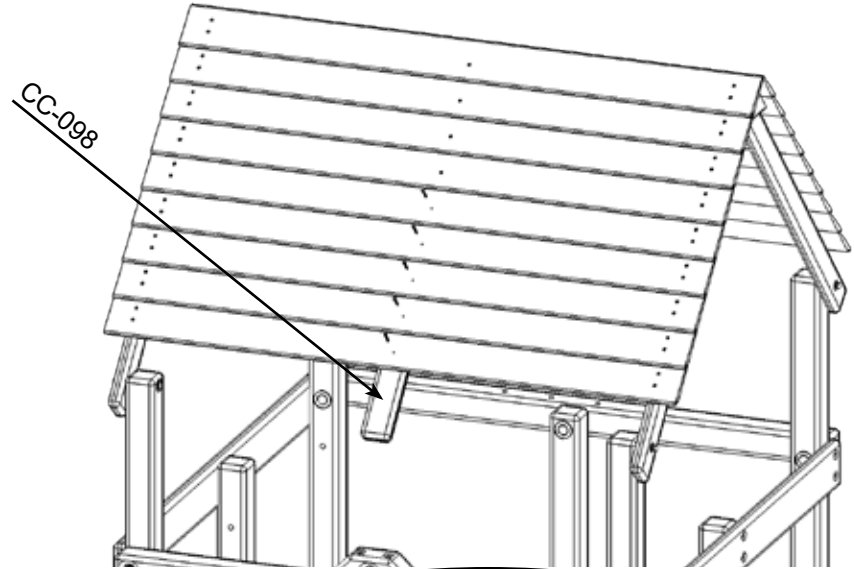
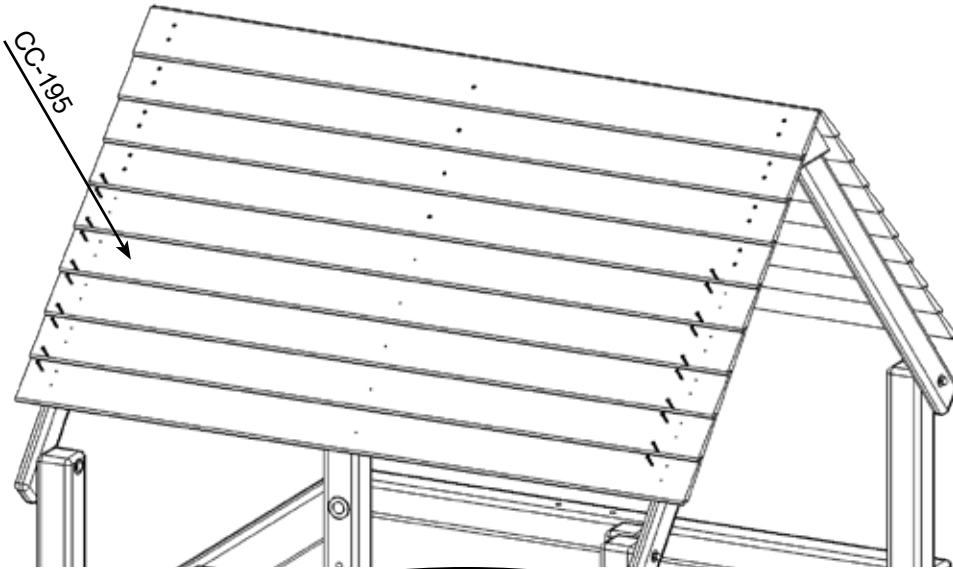

Main Assembly

PARTS NEEDED

CC-195- 67 1/2" Wood Roof Board- (4)
Fan Assembly- (2)

HARDWARE NEEDED

B- 1 1/2" Coated Deck Screw- (40)

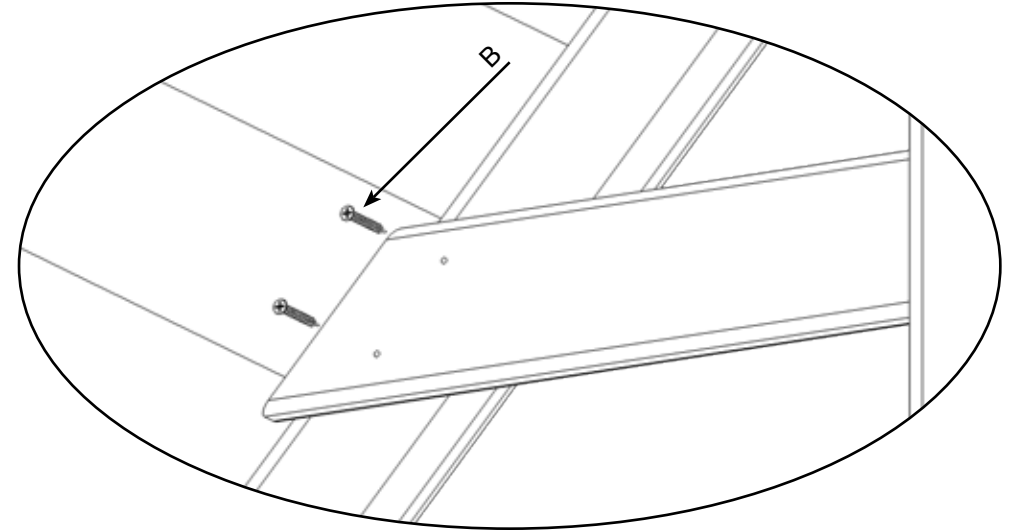
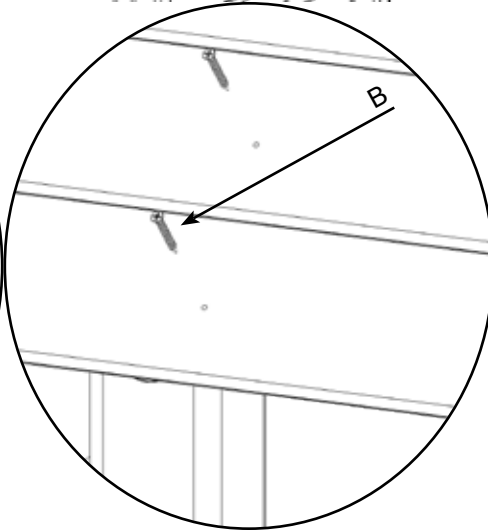
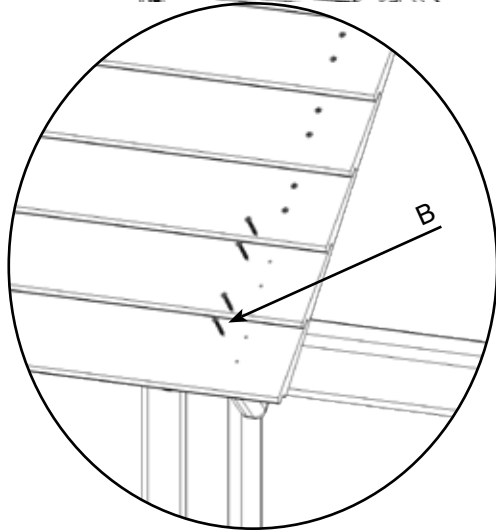
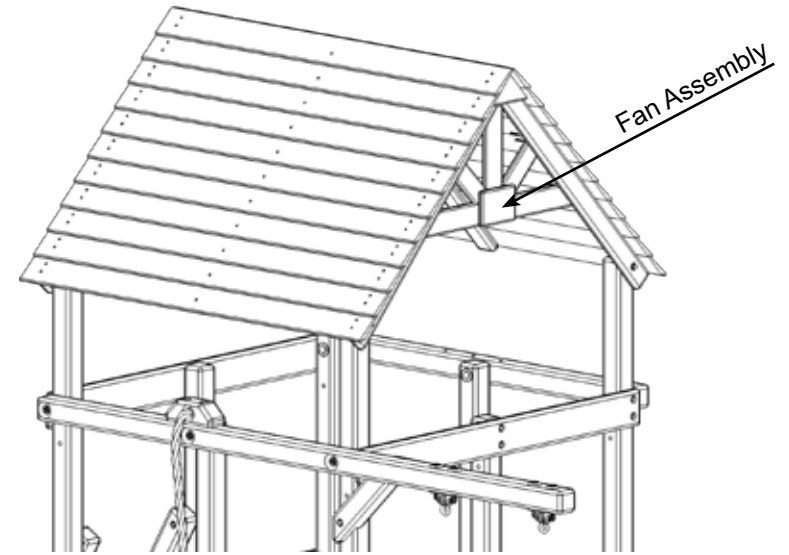
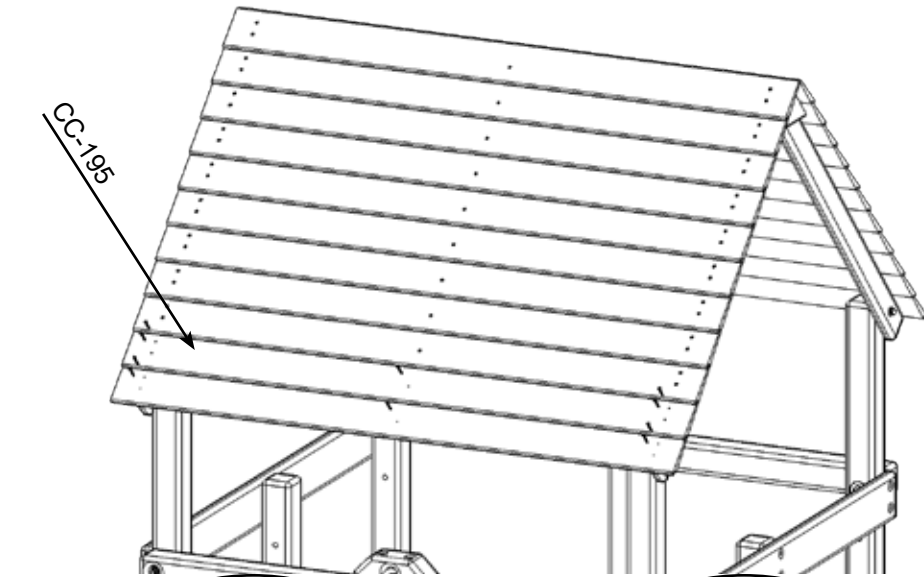

Main Assembly

PARTS NEEDED

- 405-G- 20" Trapeze Bar- (1)
- 405-L- Telescope- (1)

HARDWARE NEEDED

- A-13- 8 x 80mm Spring Clip- (2)

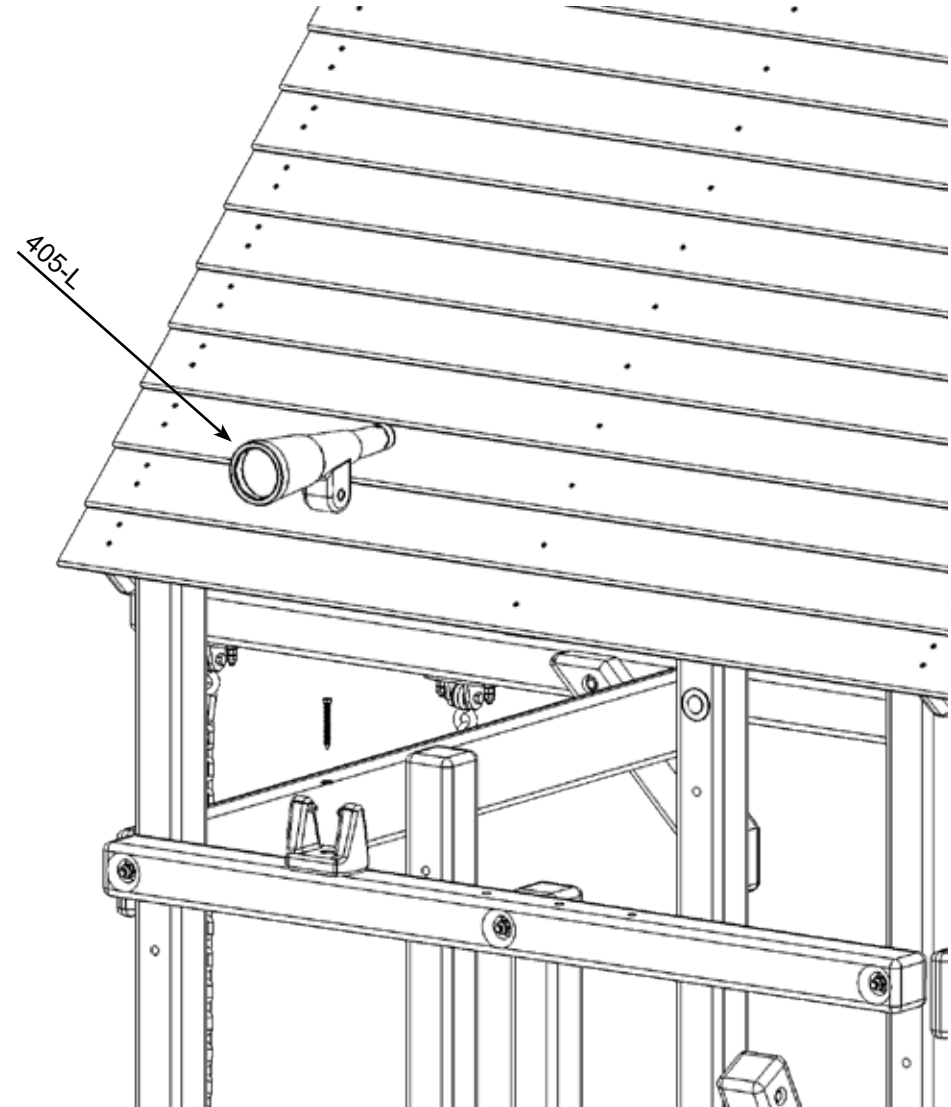
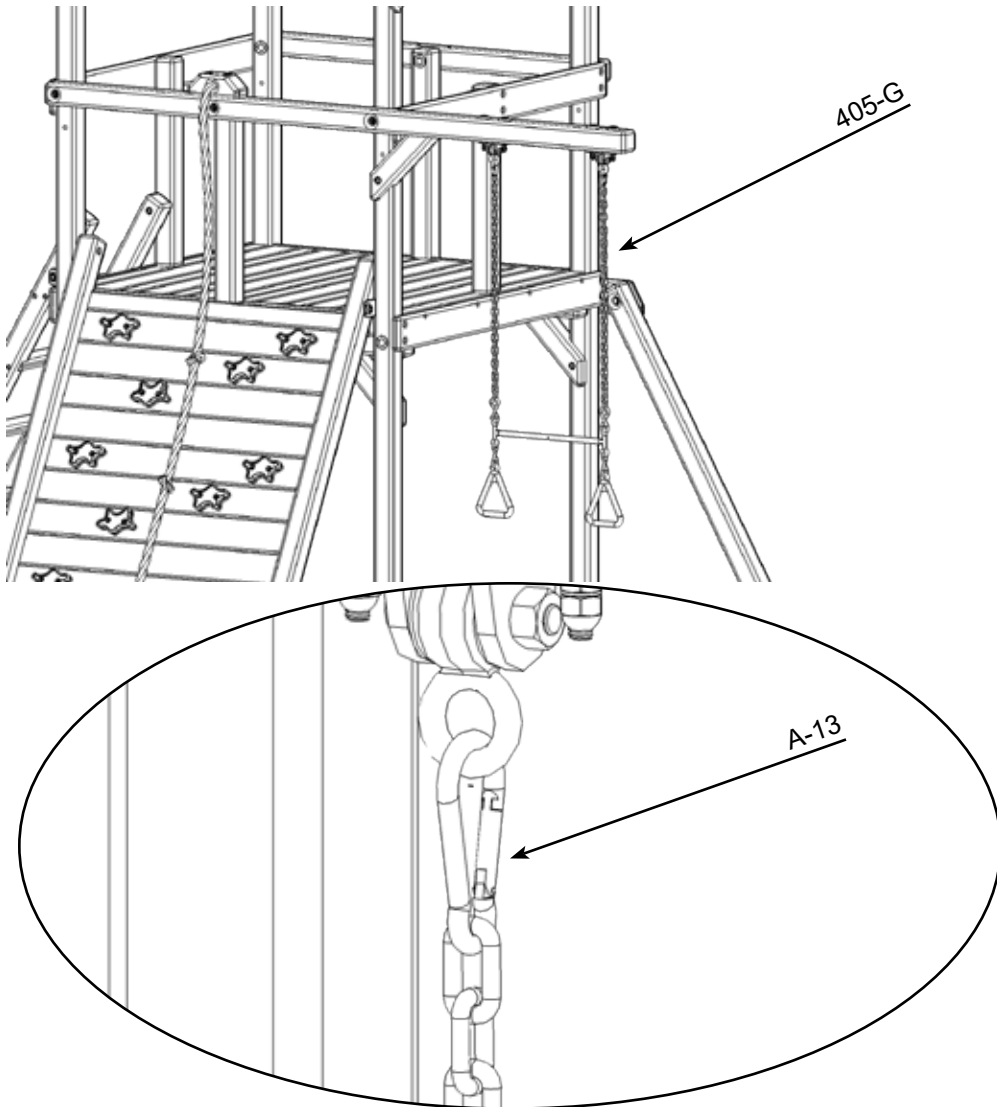

Main Assembly

PARTS NEEDED

405-M- 19" Ships' Wheel- (1)
405-E- Playgrip Ladder Handle- (2)

HARDWARE NEEDED

N- 1/4" USS Flatwasher- (4)
J- #14 x 2" Pan Phillips T/S- (4)

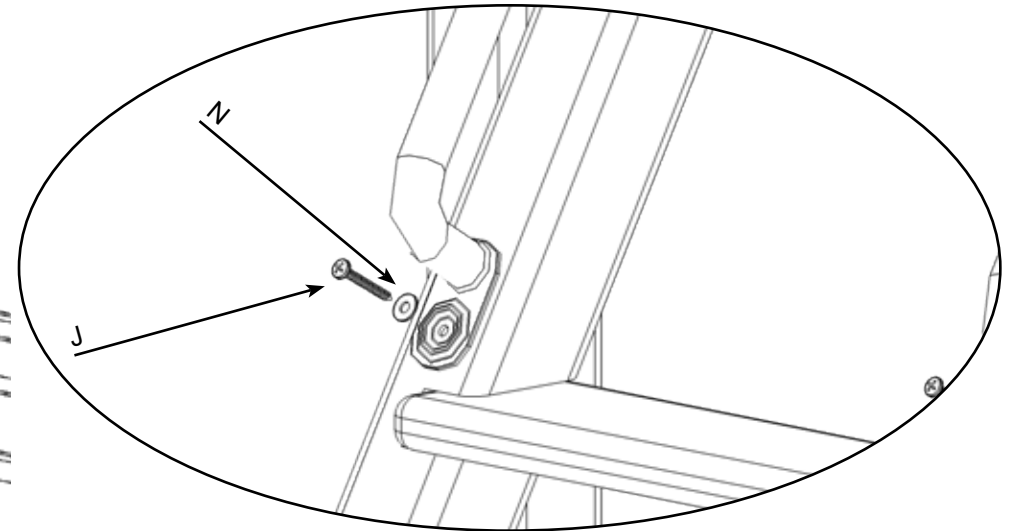
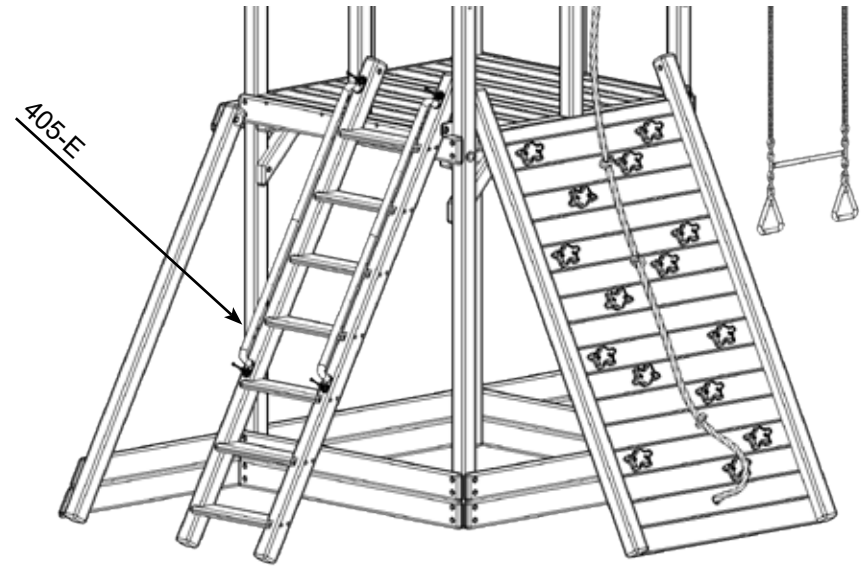
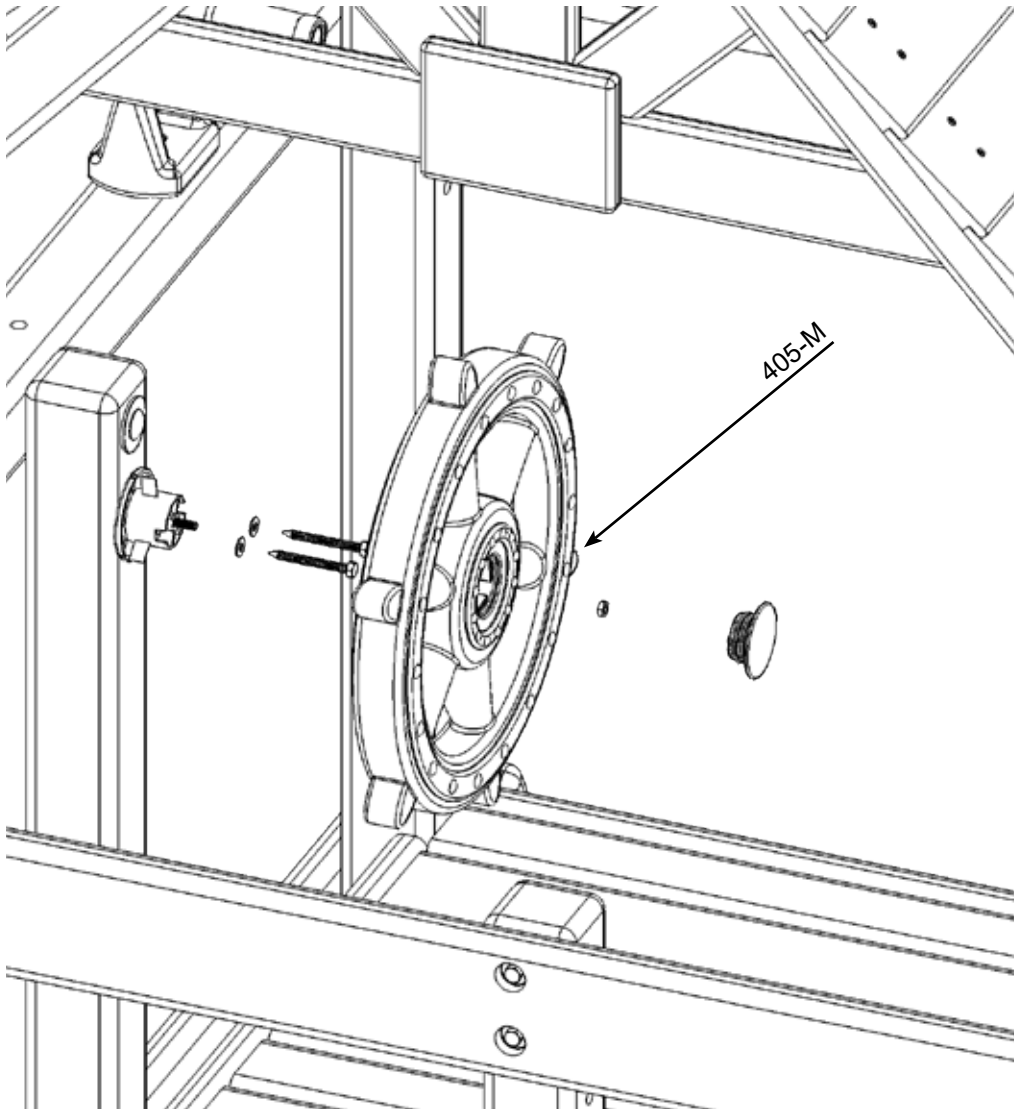

Main Assembly

PARTS NEEDED

405-D- Playgrip Safety Handle- (5)
 405-C- Swingbeam T-Plate- (1)

J- #14 x 2" Pan Phillips T/S- (10)
 SB-3- 1/2" x 3 1/2" Carriage Bolt- (2)
 SB-18- 1/2" USS Flatwasher- (2)
 SB-7- 1/2" Hex Nut- (2)

HARDWARE NEEDED

(10) N- 1/4" USS Flatwasher- (10)
 (2) SB-19- 3/4" USS Flatwasher- (2)
 (2) SB-16- 1/2" Split Lockwasher- (2)
 (2) SB-2- 1/2" Acorn Nut Plated- (2)

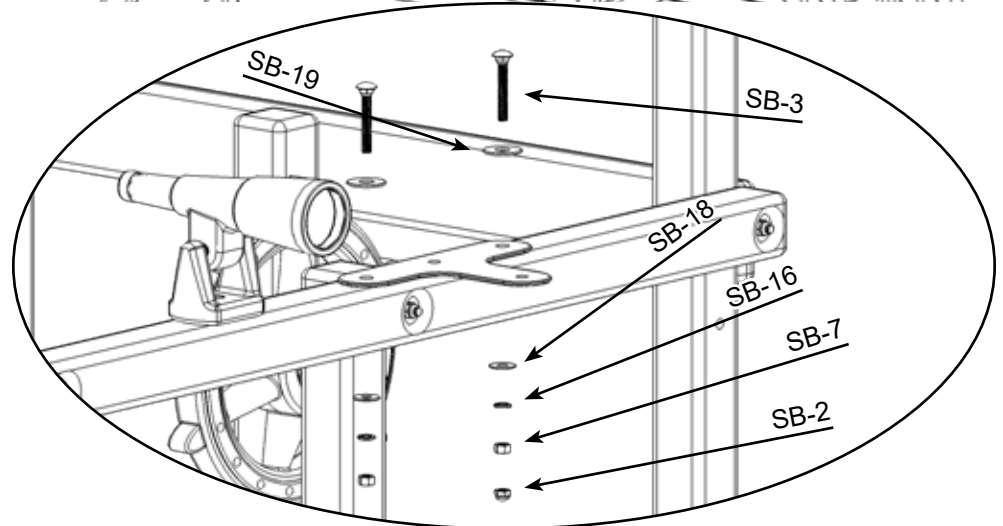
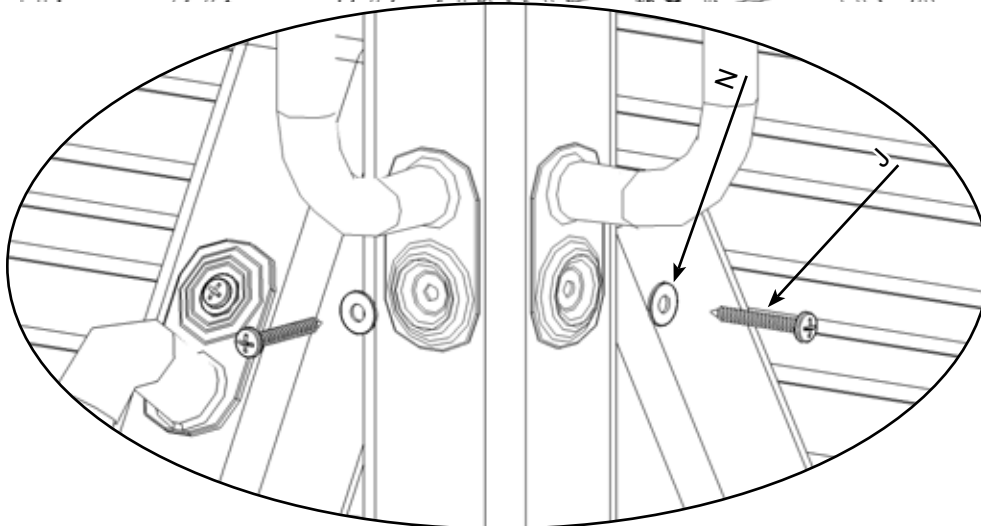
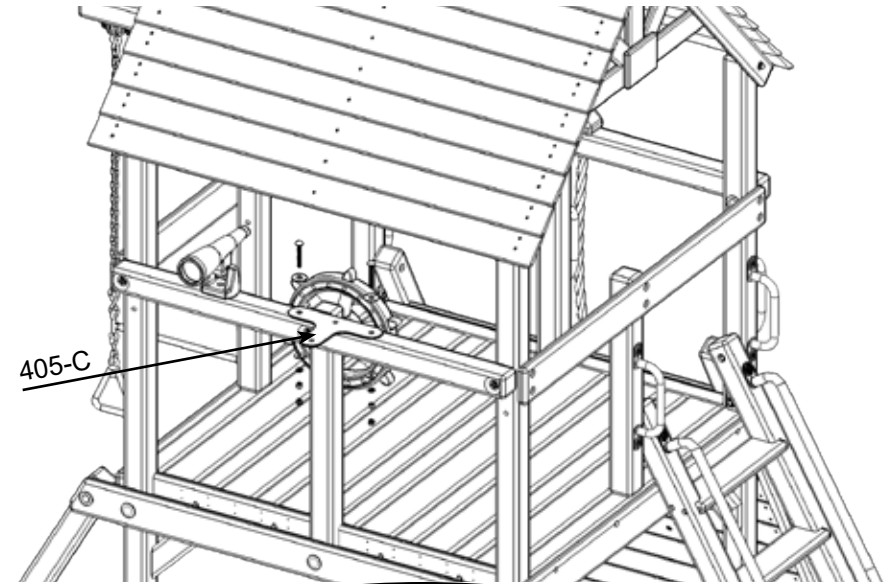
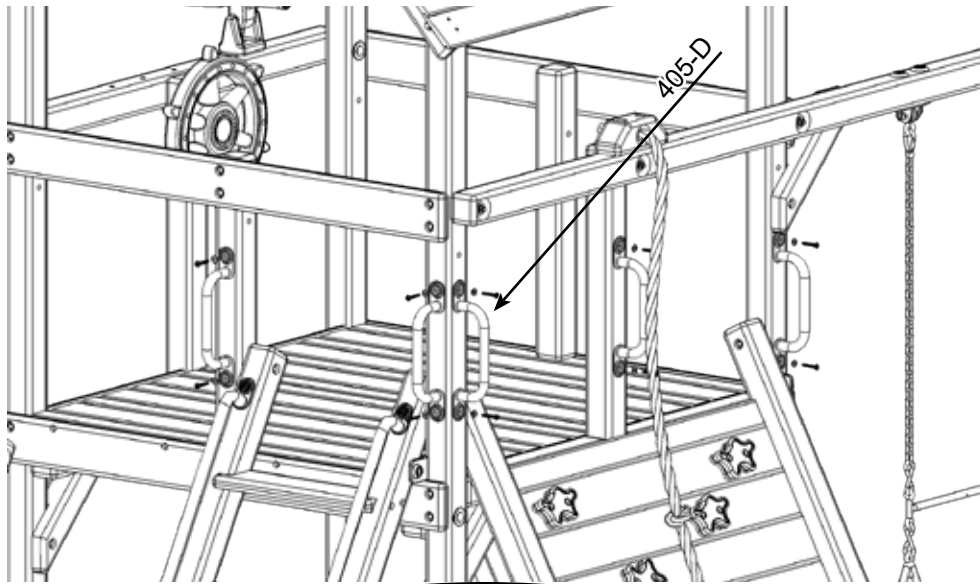

Main Assembly

PARTS NEEDED

A-Frame- (1)

SB-5- 1/2" x 9" Carriage Bolt-
 SB-19- 3/4" USS Flatwasher-
 SB-16- 1/2" Split Lockwasher-
 SB-2- 1/2" Acorn Nut Plated-
 SB-17- 3/8" USS Flatwasher-

HARDWARE NEEDED

(1) SB-4- 1/2" x 7" Carriage Bolt- (1)
 (2) SB-18- 1/2" USS Flatwashers- (2)
 (2) SB-7- 1/2" Hex Nut- (2)
 (2) SB-12- 3/8" x 5" Hex Lag Screw- (2)

LEVEL A-FRAME AND ATTACH AS SHOWN

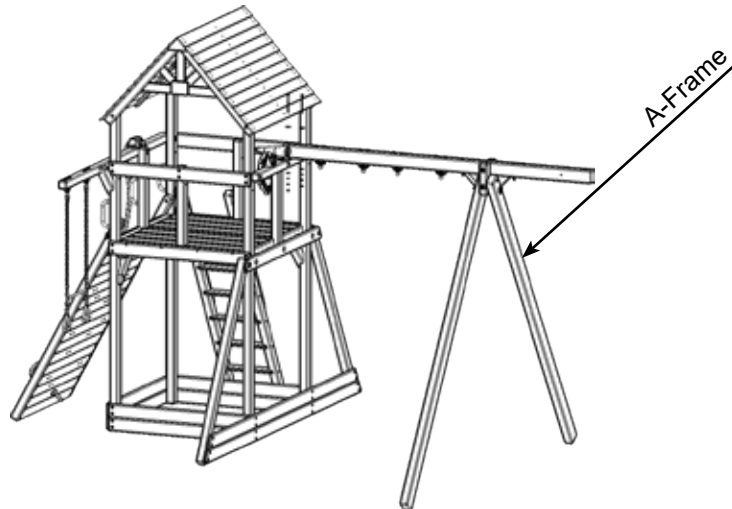

AFTER ATTACHING AND LEVELING SECURE IN POSITION AS SHOWN

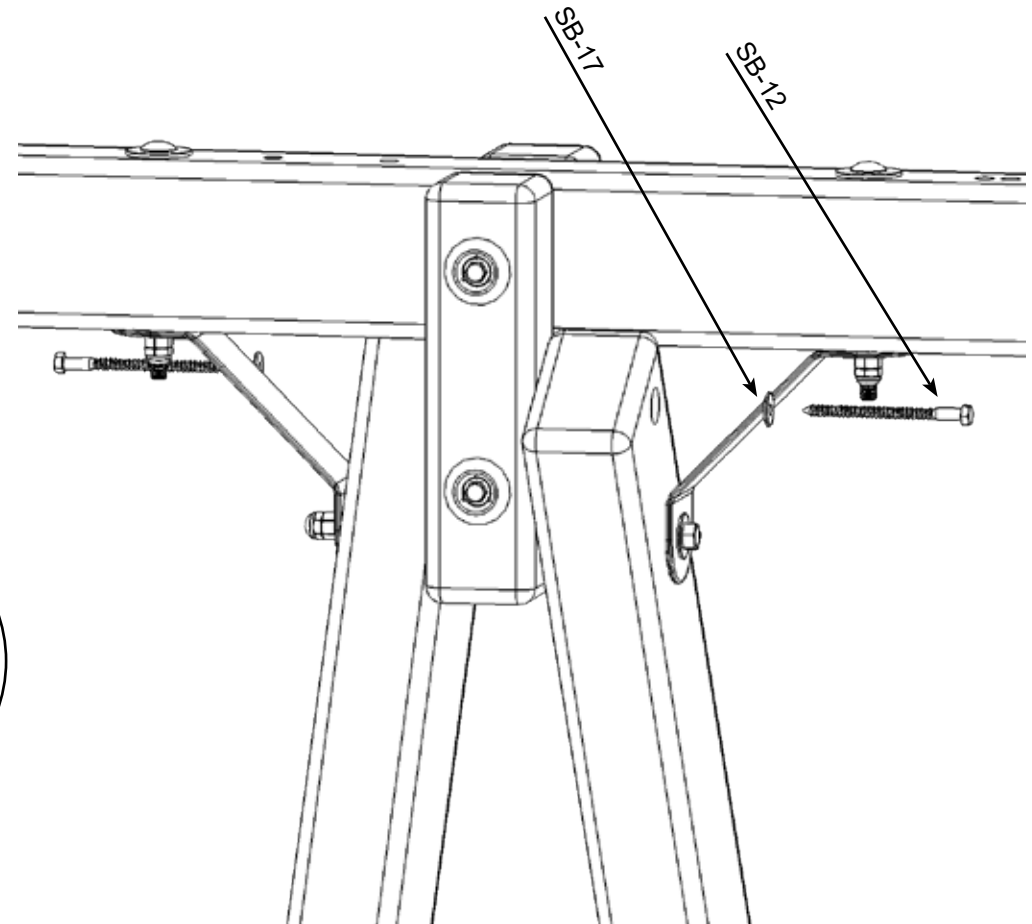
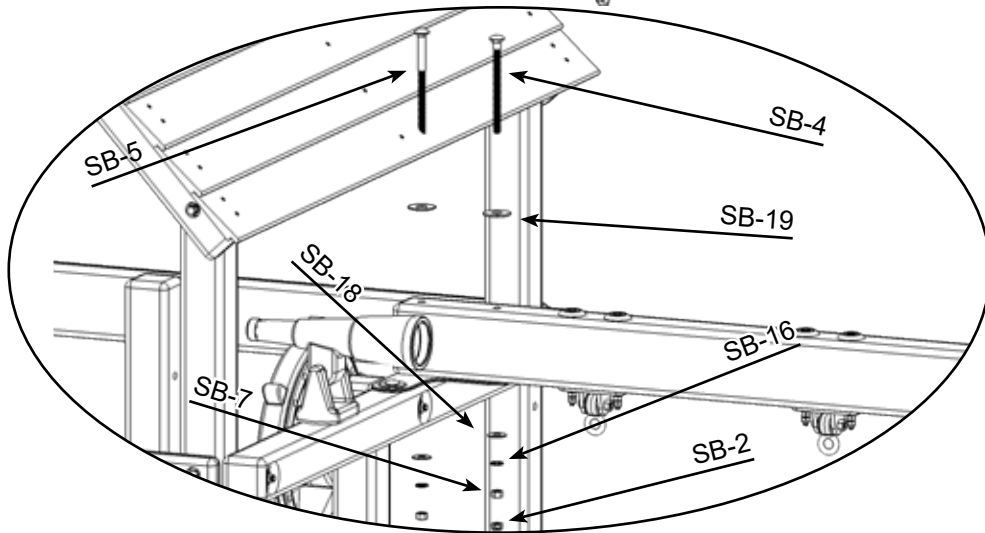

Main Assembly

PARTS NEEDED

CC-245- 88" A-Frame Crossmember- (1)
 405-J- 84" Chained Belt Swing- (2)

SB-4- 1/2" x 7" Carriage Bolt- (2)
 SB-18- 1/2" USS Flatwasher- (2)
 SB-7- 1/2" Hex Nut- (2)
 SB-21- 8 x 80mm Spring Clip- (4)

HARDWARE NEEDED

SB-19- 3/4" USS Flatwasher- (2)
 SB-16- 1/2" Split Lockwasher- (2)
 SB-2- 1/2" Acorn Nut Plated- (2)

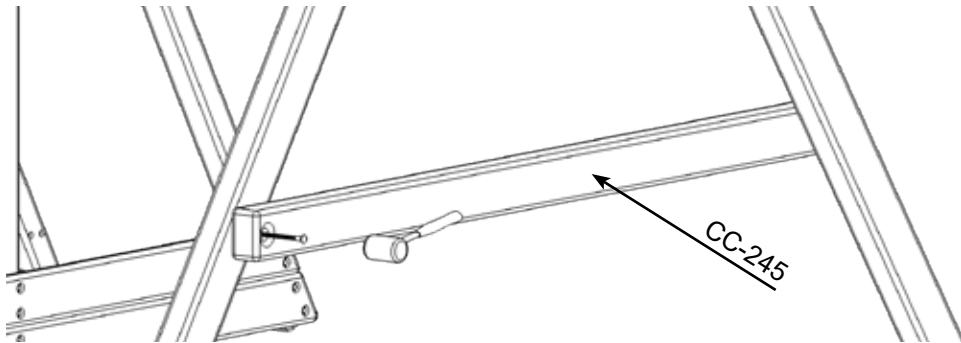

LEVEL CROSSMEMBER ACROSS A-FRAME LEGS AND MARK HOLES TO BE DRILLED

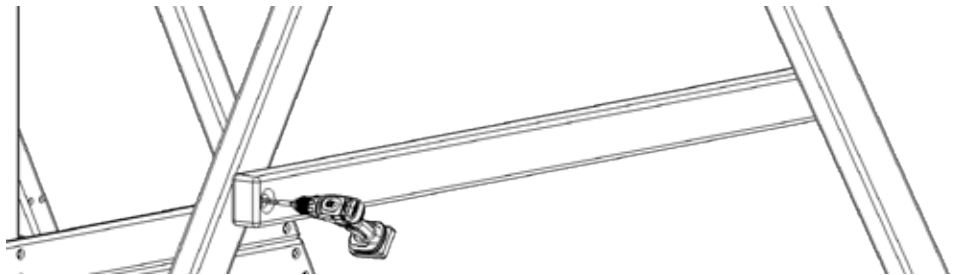

USING A 9/16" DRILL BIT; DRILL OUT MARKED HOLES AND ATTACH AS SHOWN BELOW

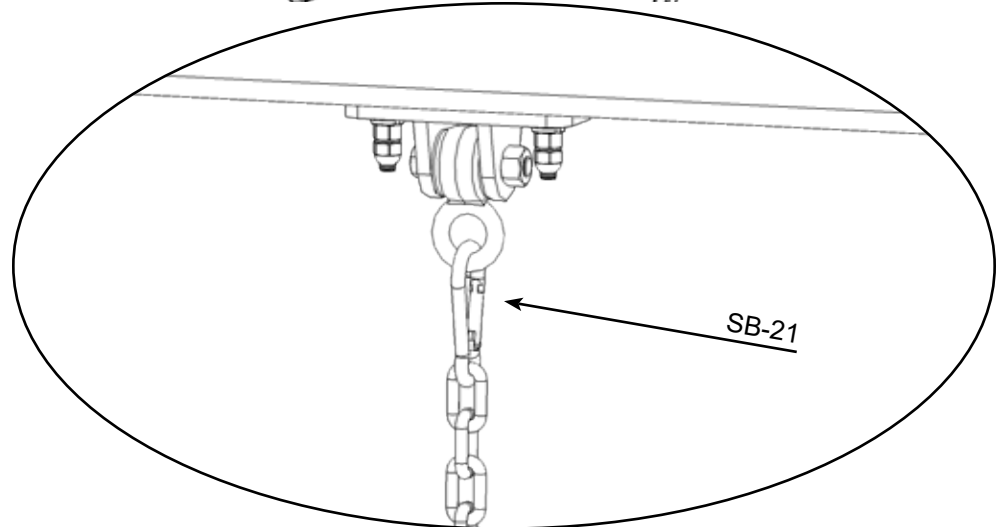
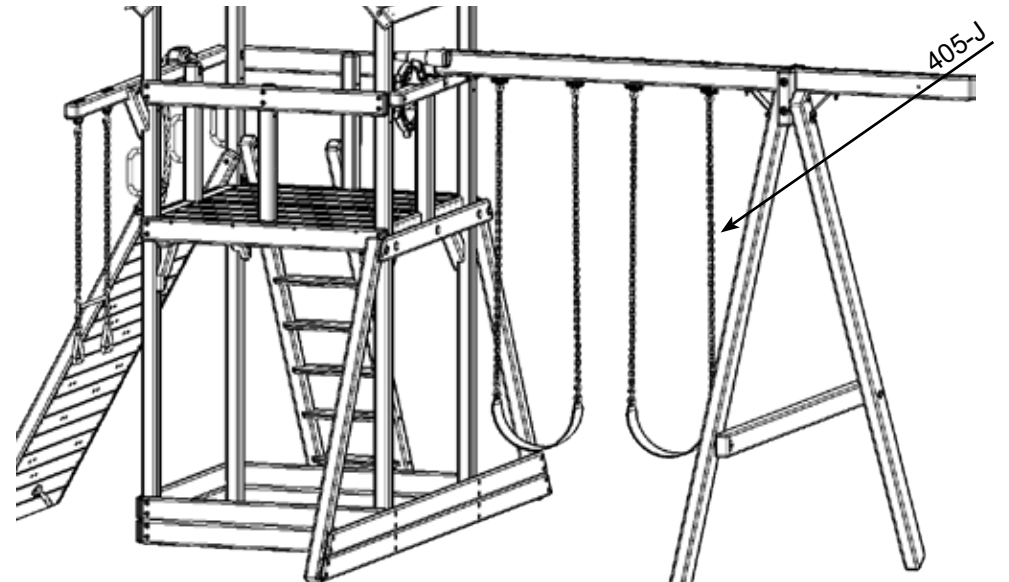
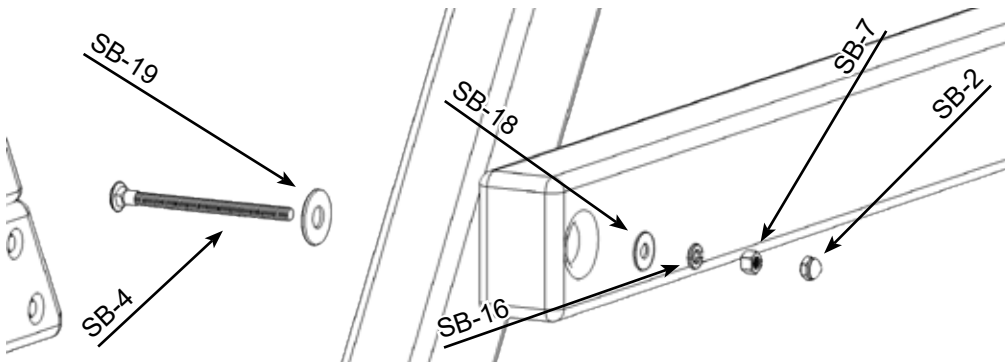

Main Assembly

PARTS NEEDED

405-F- 16' Yellow Rope-
405-H- Disc Swing-

(1)
(1)

Finished Main Assembly

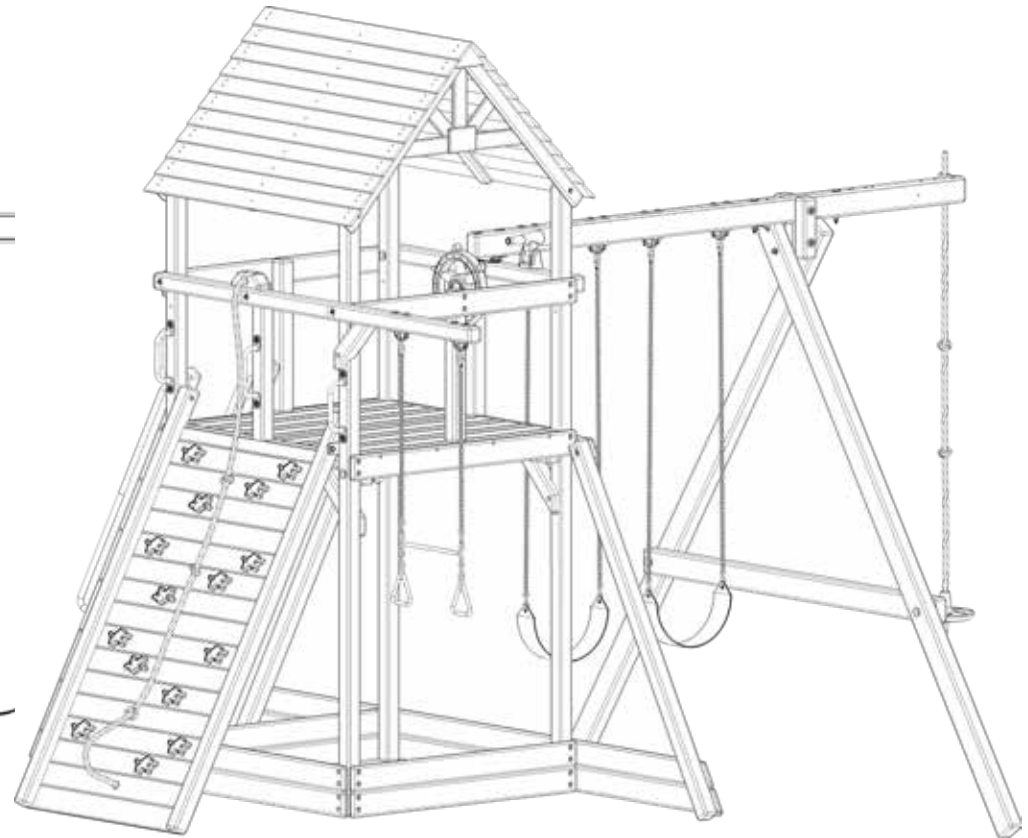
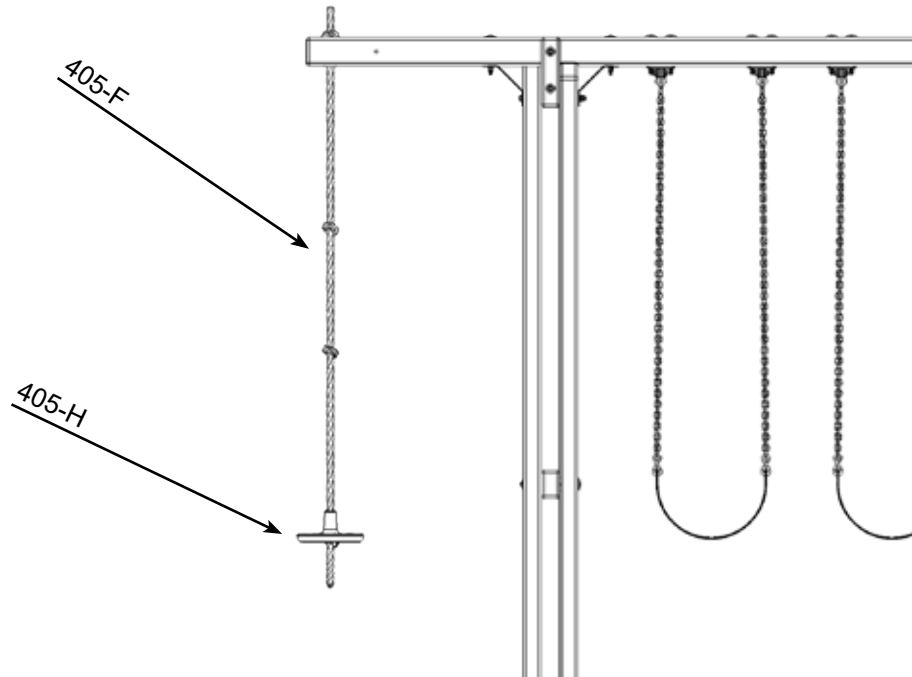

SLIP THE ROPE THROUGH THE SWINGBEAM AND TIE A KNOT. THEN TIE A KNOT EVERY 2 TO 3 FEET. PLACE THE 405-H DISC SWING ON THE ROPE AND TIE A DOUBLE KNOT SECURING IT TO THE ROPE.

Picnic Table/ Lower Floor Sub-Assemblies

PARTS NEEDED

CC-092- 12 7/8" Picnic Side Support-	(4)	CC091- 12 7/8" Center Picnic Seat Support-	(2)
CC-126- 60 3/4" Picnic Table Board-	(7)	CC-113- 54" Picnic Table Board-	(1)
CC-106- 28 1/4" Picnic Side Support-	(2)	CC-105- 28 1/4" Picnic Center Support-	(1)
CC-117- 60 3/4" Picnic Table Board-	(4)		

HARDWARE NEEDED

D- 2 1/2" Coated Deck Screw-	(78)
------------------------------	------

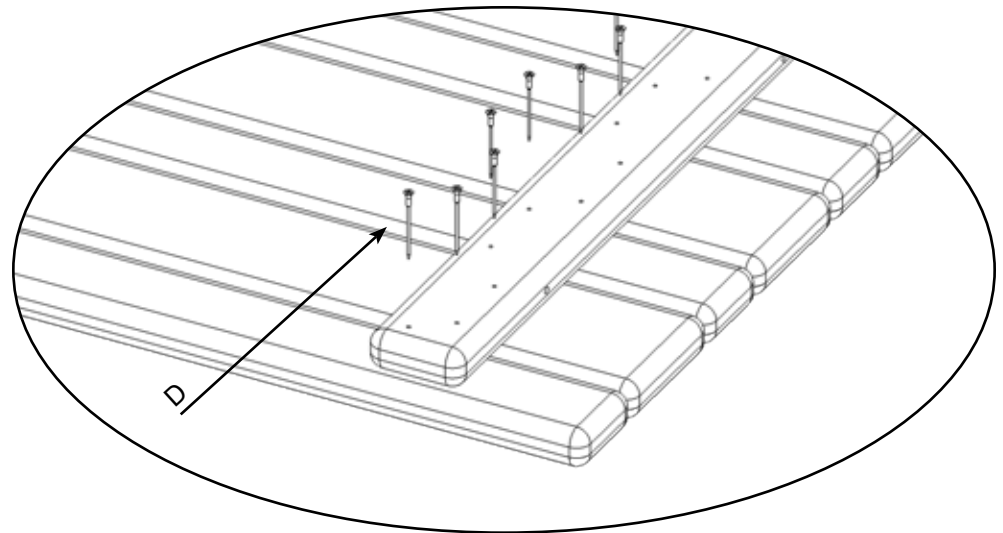
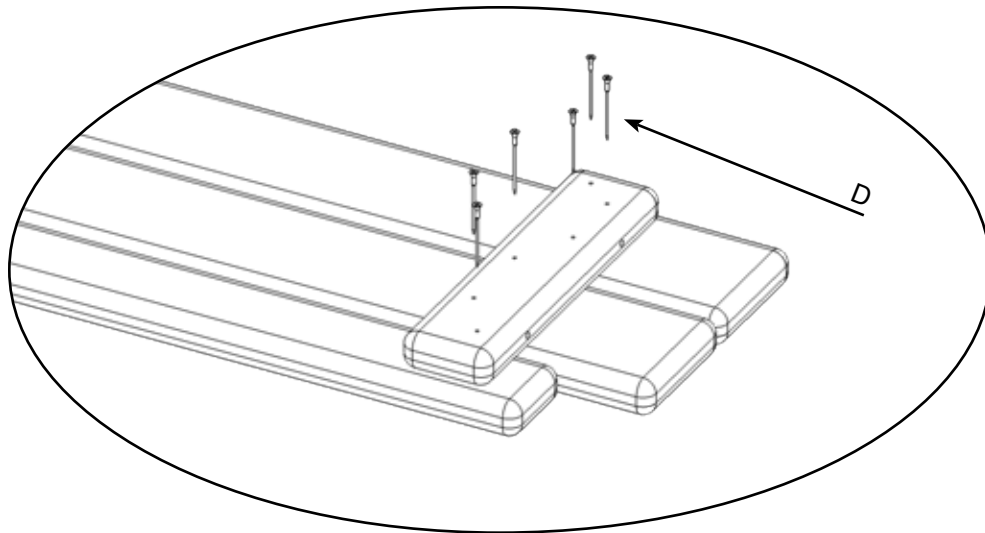
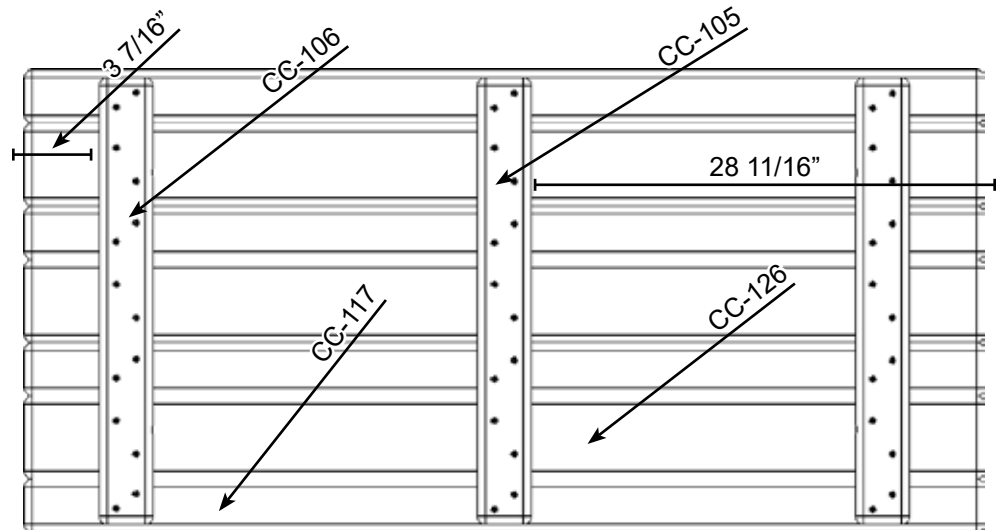
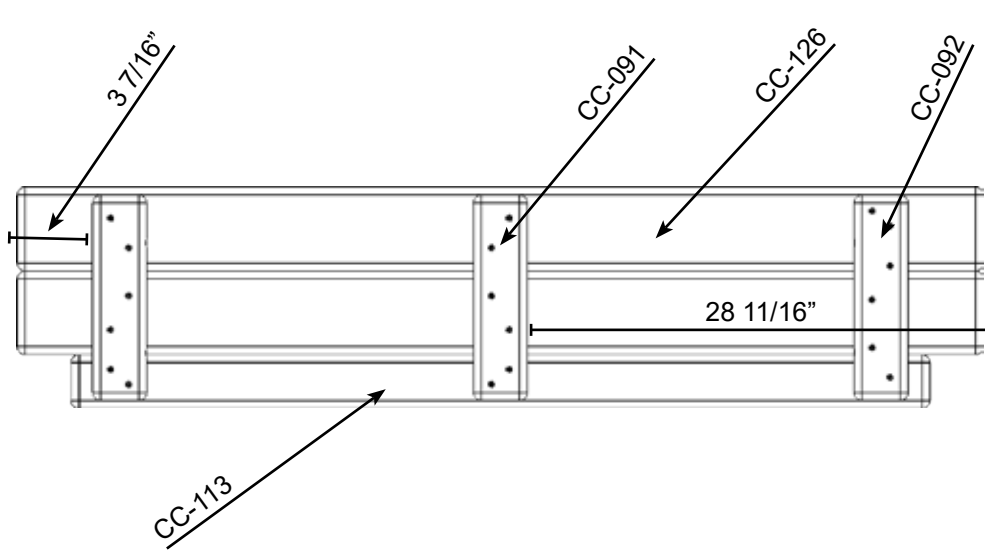

Picnic Table Install (Skip for Lower Floor)

PARTS NEEDED

CC-115- 60 1/4" Picnic Support- (2)

HARDWARE NEEDED

O- 3/8" USS Flatwasher- (4)

H- 3/8" x 3 1/2" Hex Lag Screw- (4)

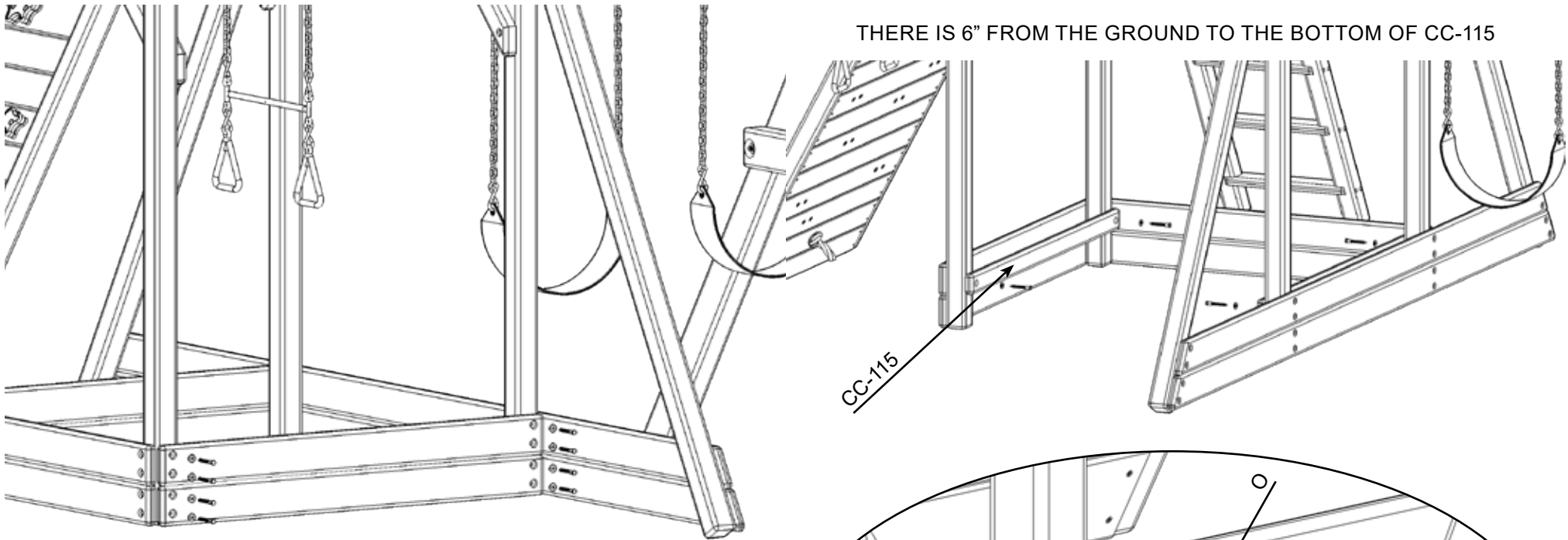

REMOVE THE LOWER FACIA BOARDS FOR EASY ACCESS TO THE LOWER PART OF THE UNIT.

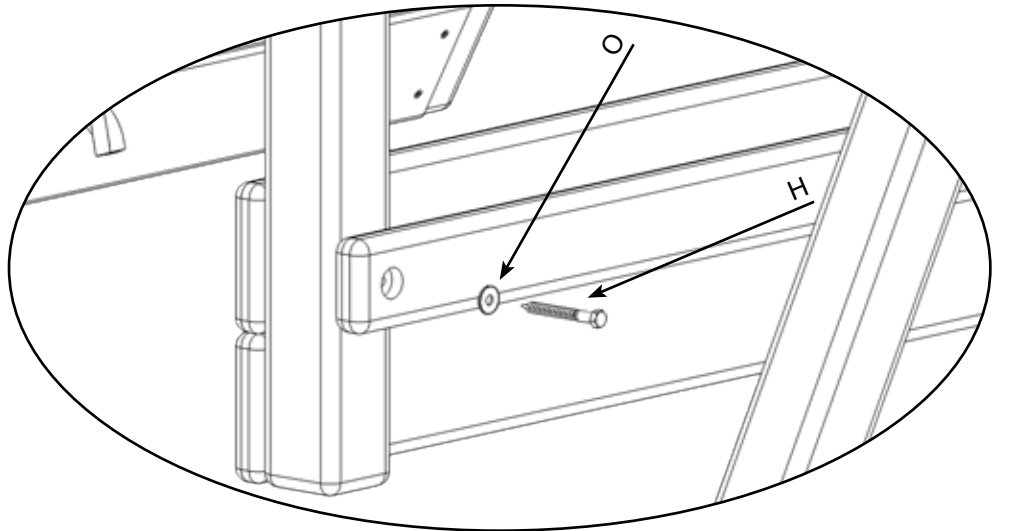

Picnic Table Install (Skip for Lower Floor)

PARTS NEEDED

- Seat Assembly- (1)
- CC-115- 60 1/4" Picnic Support- (1)

HARDWARE NEEDED

- G- 1/4" x 4 1/2" Hex Lag Screw- (4)
- N- 1/4" USS Flatwasher- (4)
- O- 3/8" USS Flatwasher- (4)
- H- 3/8" x 3 1/2" Hex Lag Screw- (4)

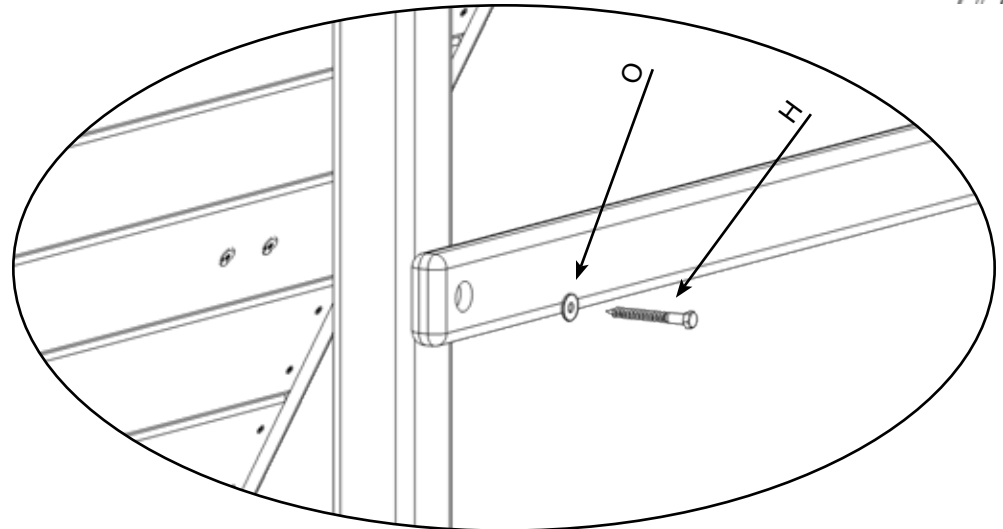
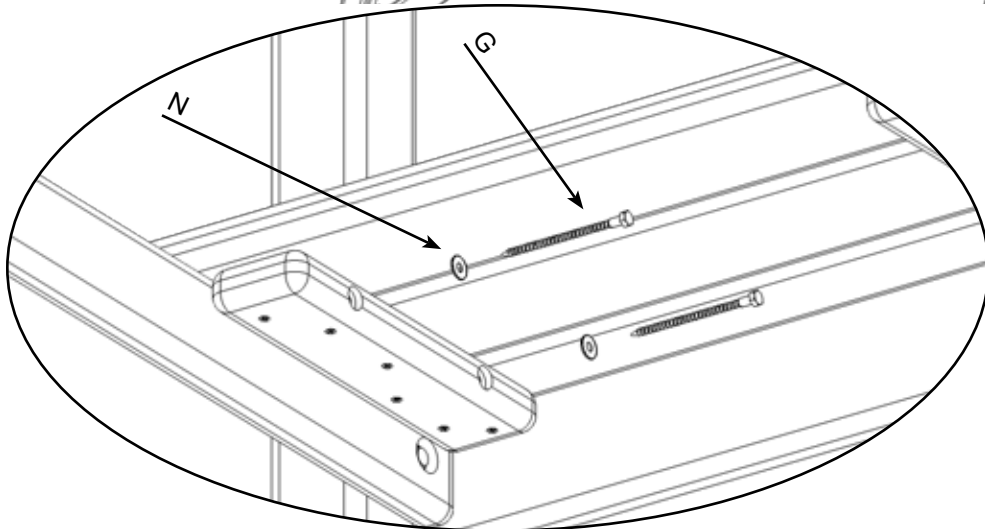
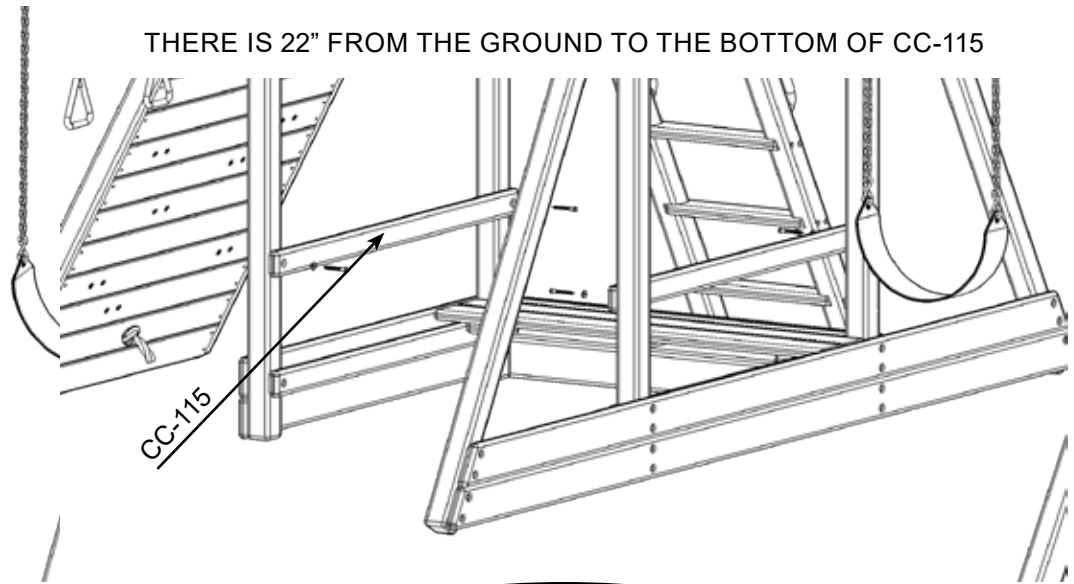
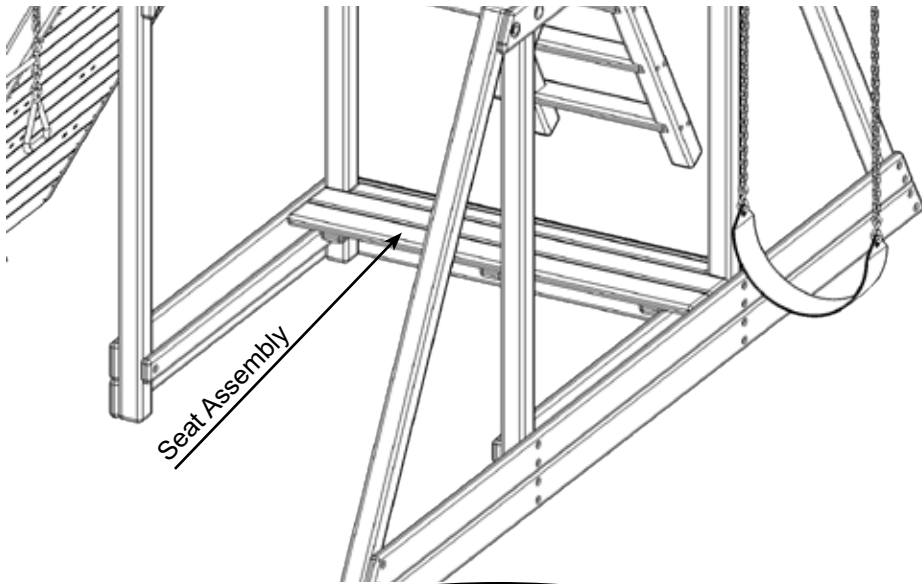

Picnic Table Install (Skip for Lower Floor)

PARTS NEEDED

Table Assembly- (1)
Seat Assembly- (1)

HARDWARE NEEDED

G- 1/4" x 4 1/2" Hex Lag Screw- (8)
N- 1/4" USS Flatwasher- (8)

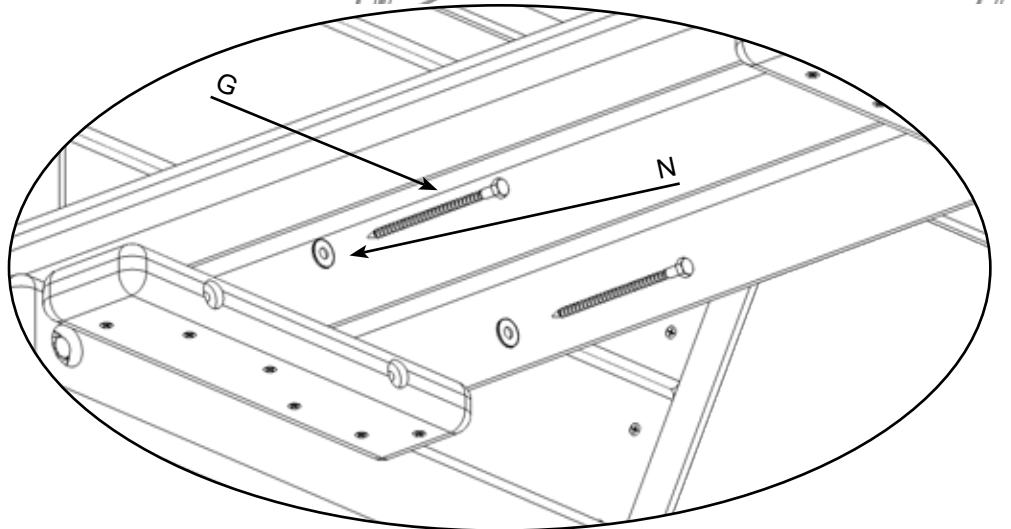
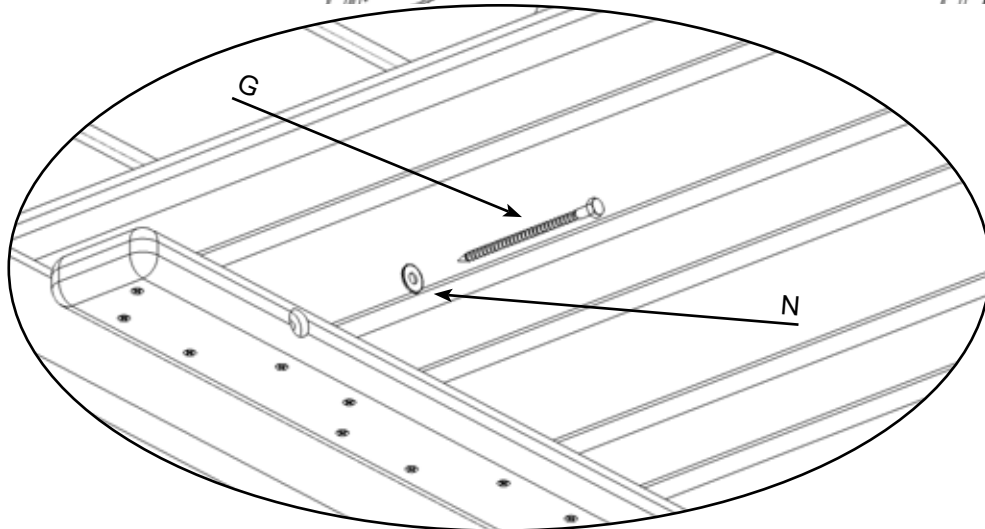
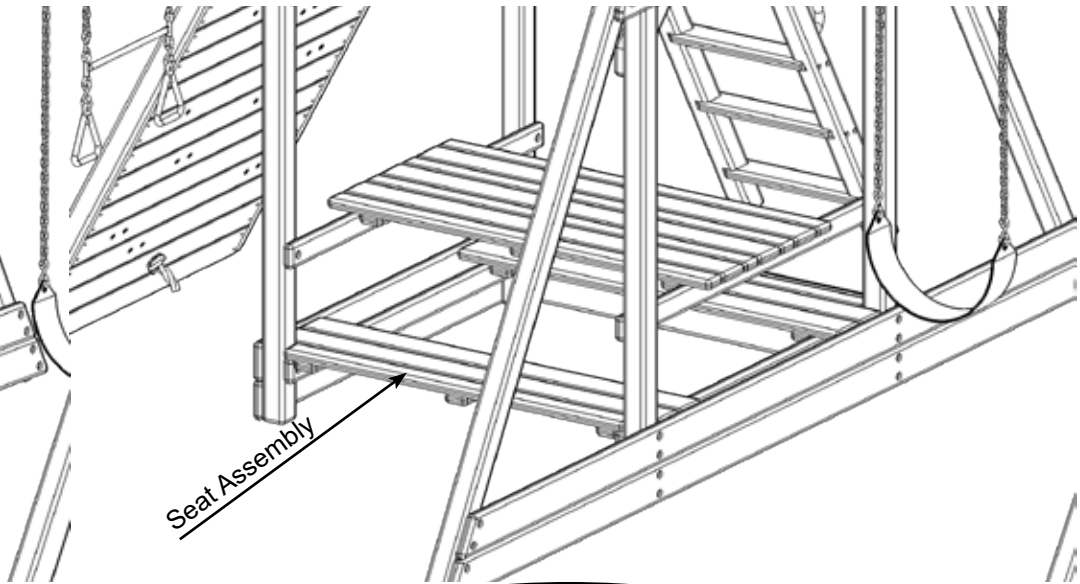
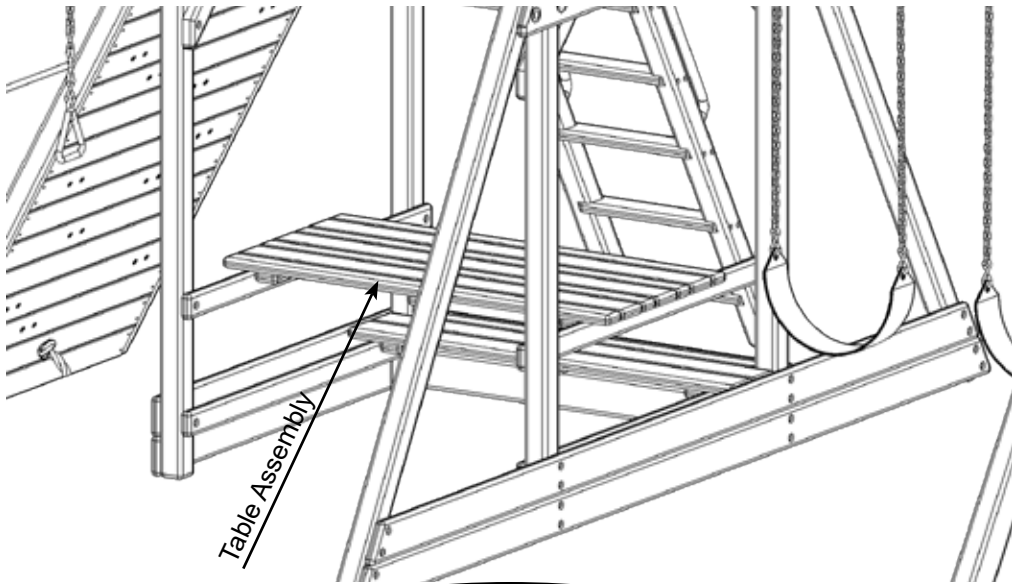

Picnic Table Install (Skip for Lower Floor)

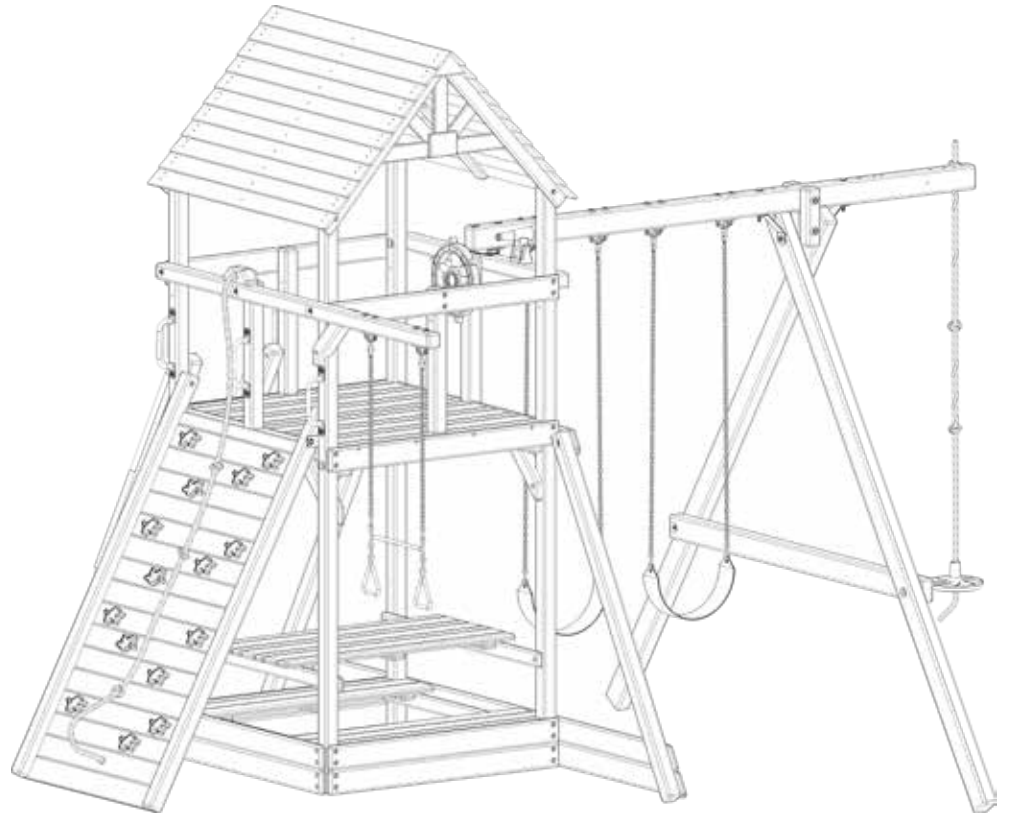
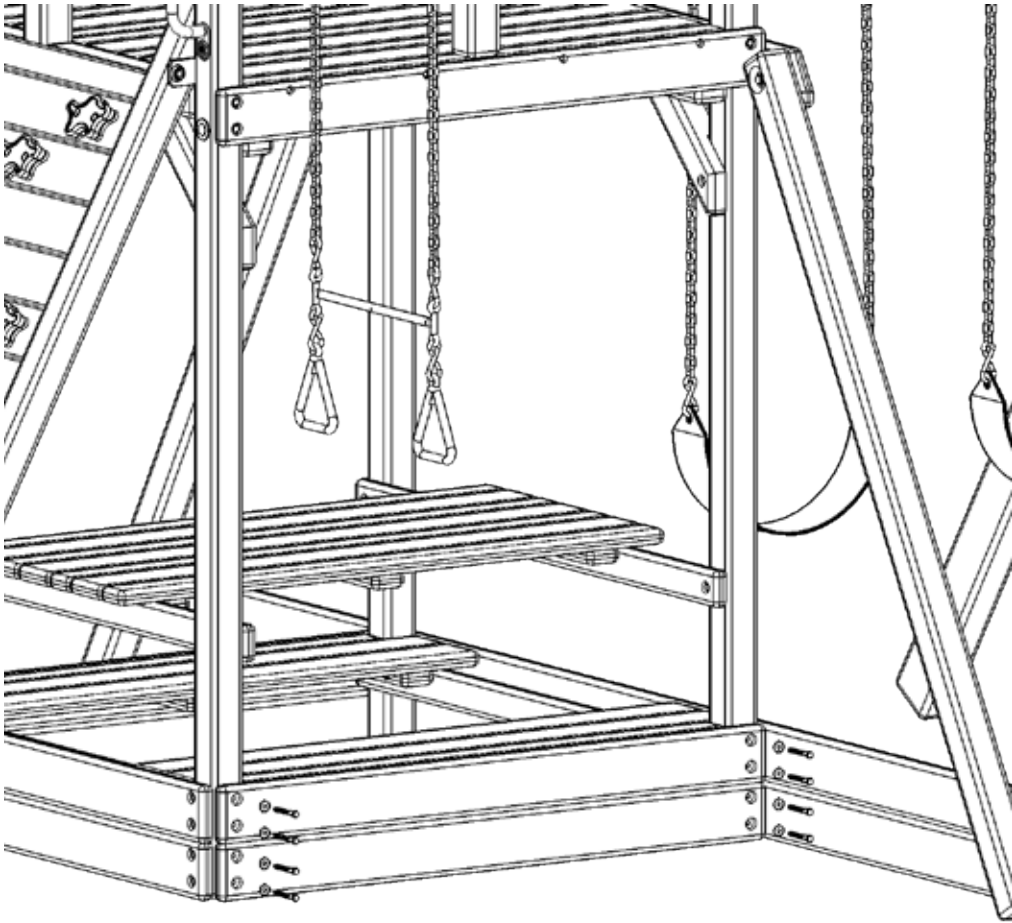

PLACE THE OUTSIDE FACIAS BACK ON THE UNIT. THE PICNIC INSTALL IS COMPLETE.

Lower Floor Install (Used Mainly For Playhouse Panels)

PARTS NEEDED

CC-115- 60 1/4" Picnic Support- (2)

HARDWARE NEEDED

H- 3/8" x 3 1/2" Hex Lag Screw- (4)

O- 3/8" USS Flatwasher- (4)

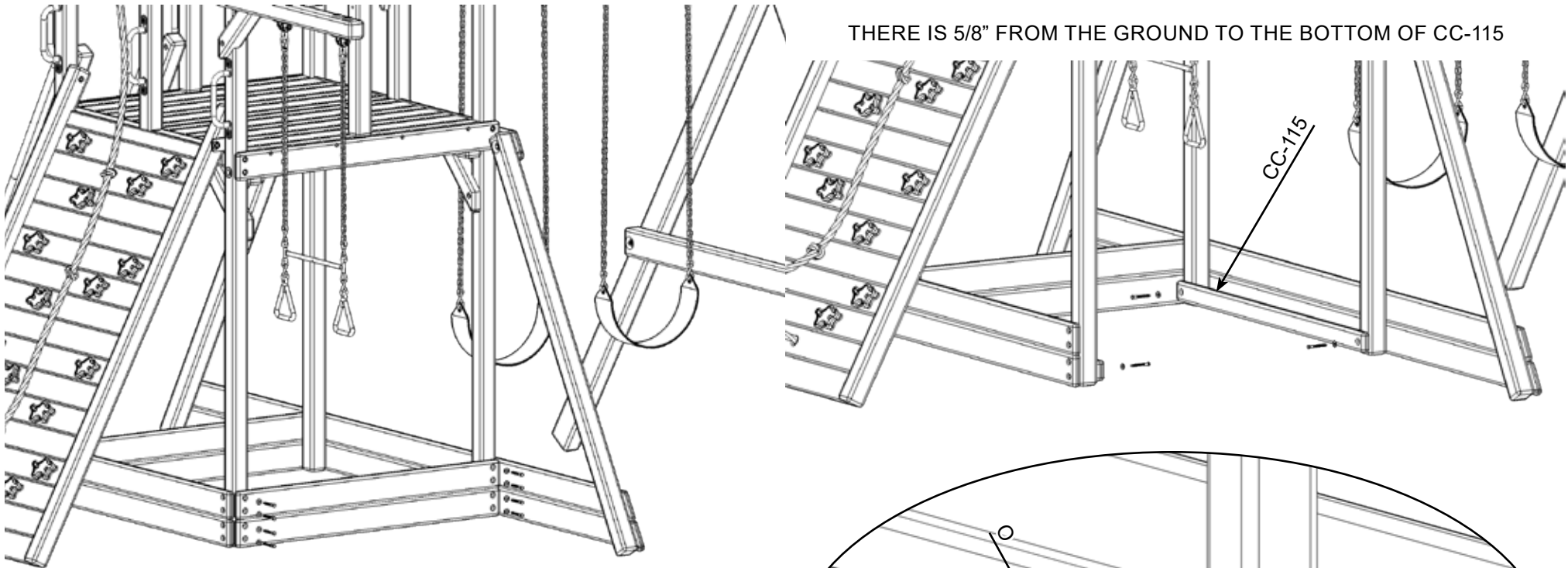

REMOVE THE LOWER FACIA BOARDS FOR EASY ACCESS TO THE LOWER PART OF THE UNIT.

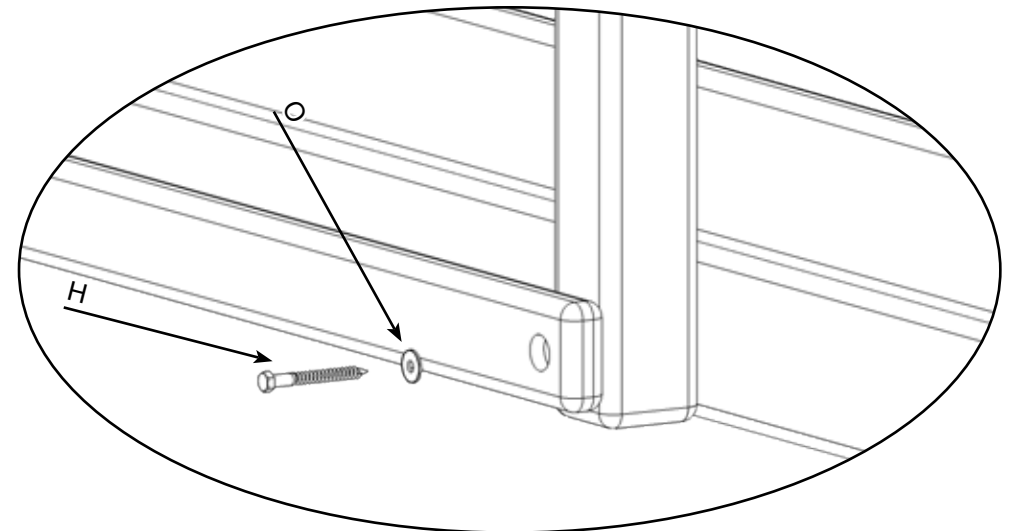

Lower Floor Install (Used Mainly For Playhouse Panels)

PARTS NEEDED

Seat Assembly- (1)
CC-090- 60 3/4" Lower Deck Filler- (1)

HARDWARE NEEDED

N- 1/4" USS Flatwasher- (4)
G- 1/4" x 4 1/2" Hex Lag Screw- (4)
D- 2 1/2" Coated Deck Screw- (4)

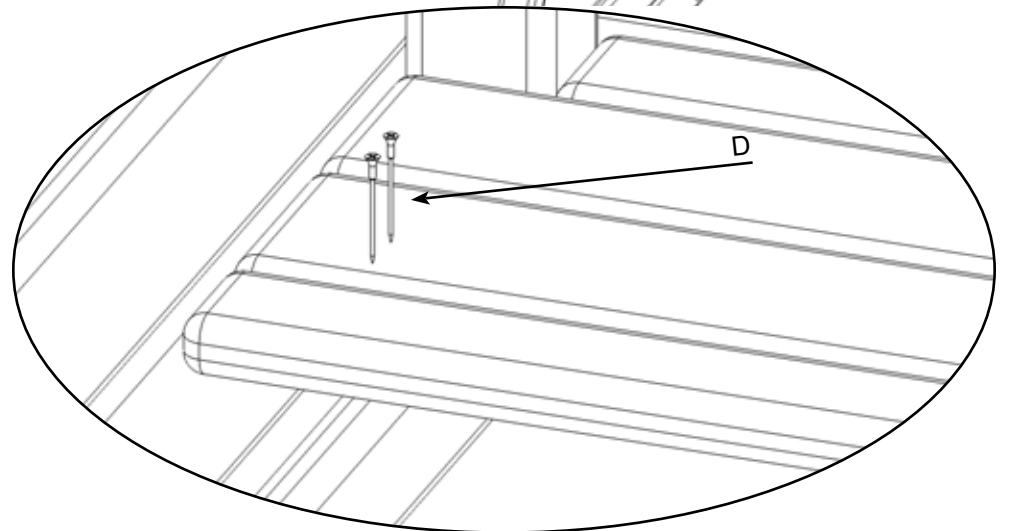
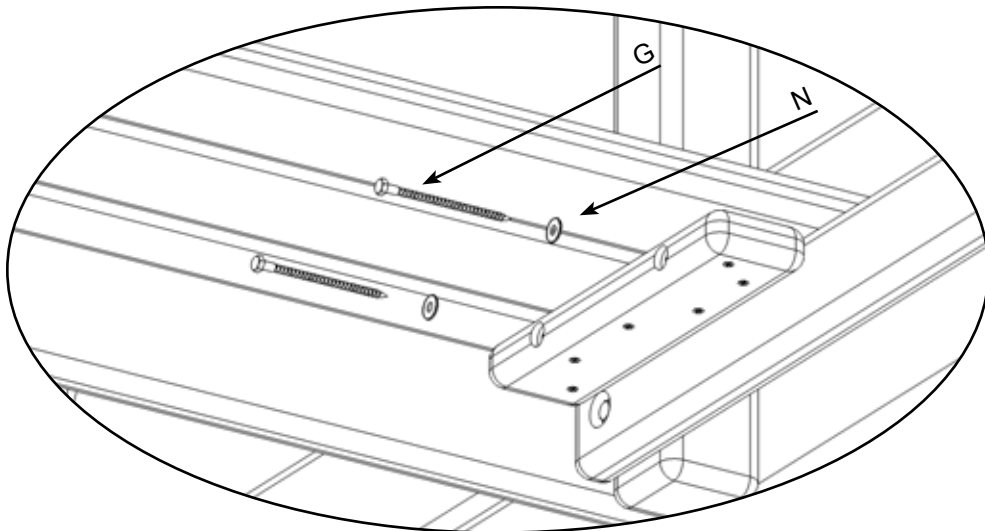
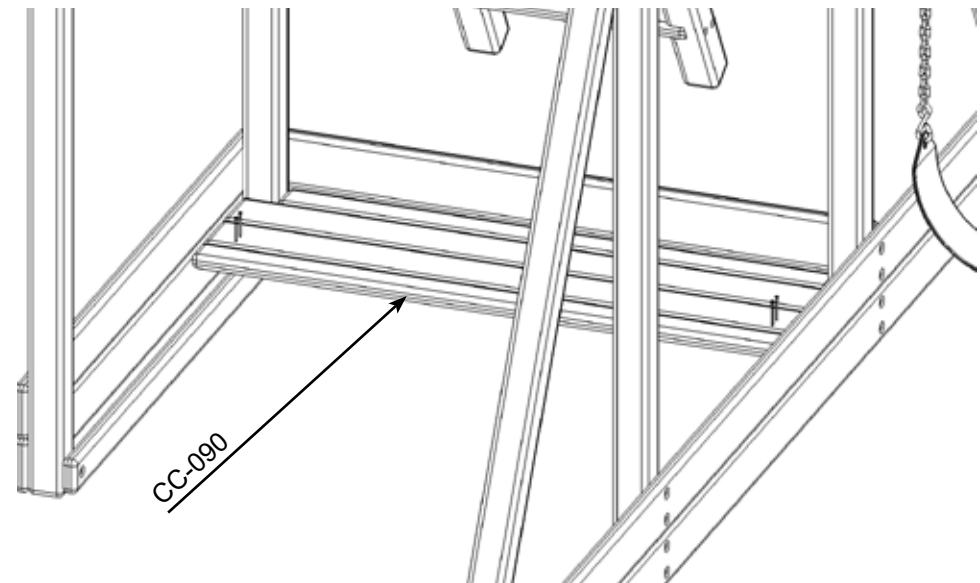
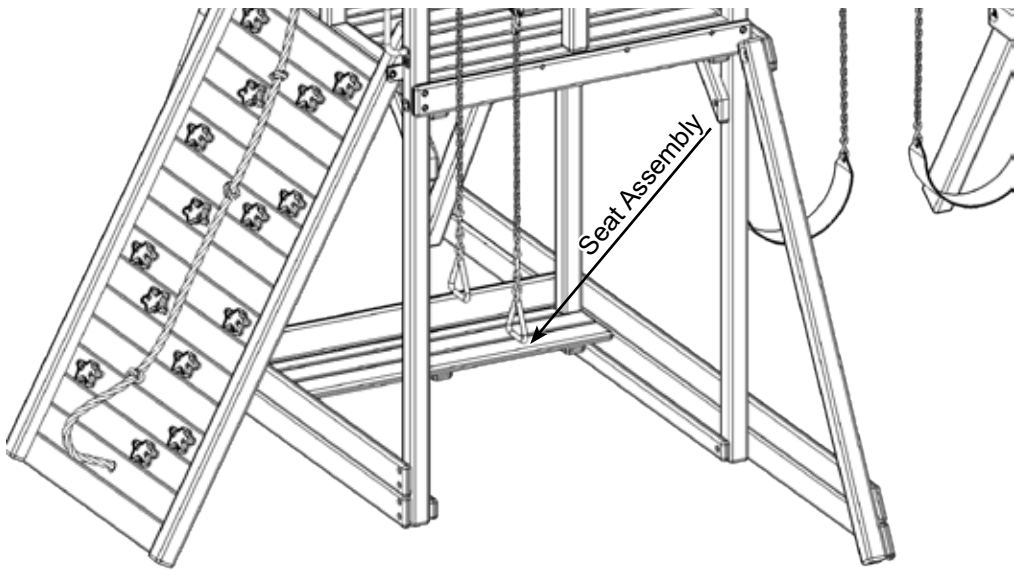

Lower Floor Install (Used Mainly For Playhouse Panels)

PARTS NEEDED

Seat Assembly- (1)
Table Assembly- (1)

HARDWARE NEEDED

G- 1/4" x 4 1/2" Hex Lag Screw- (8)
N- 1/4" USS Flatwasher- (8)

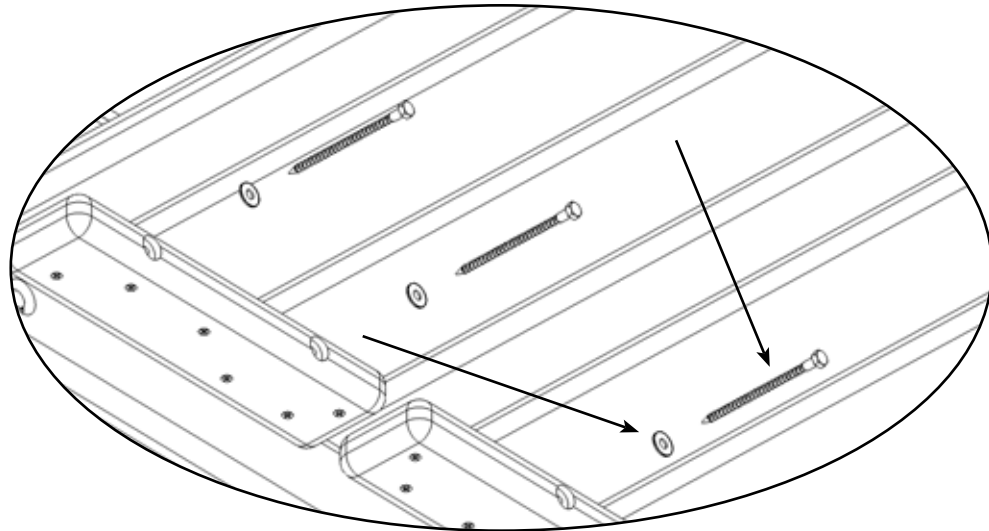
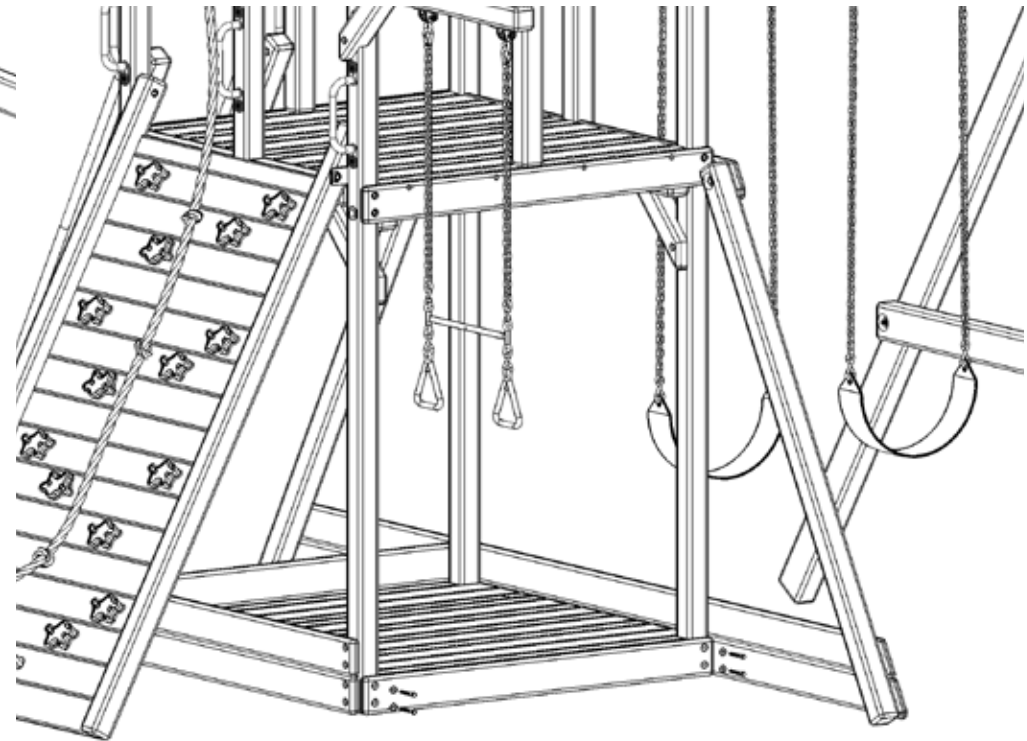
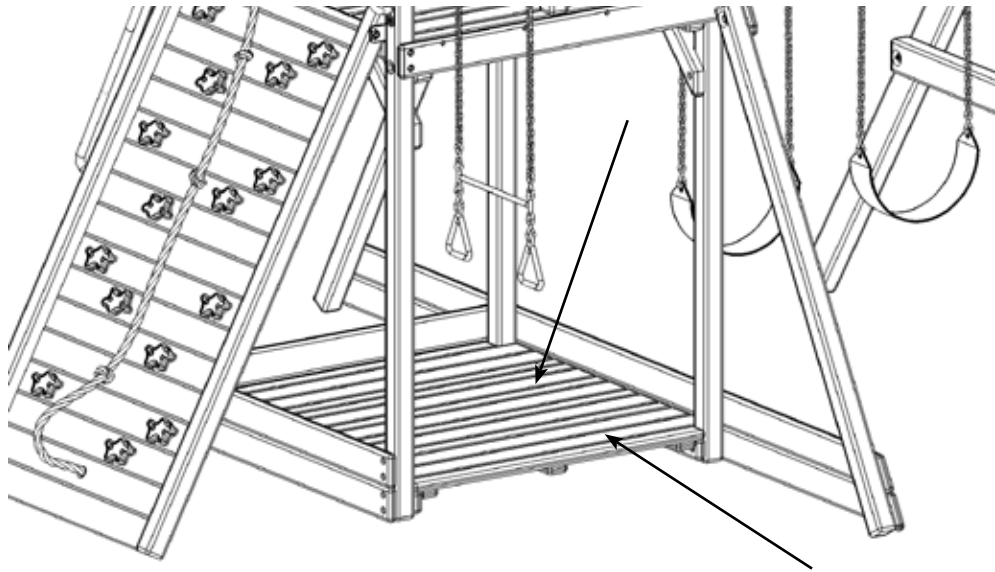

PLACE THE OUTSIDE FACIAS BACK ON THE UNIT. THE PICNIC INSTALL IS COMPLETE.

Lower Floor Install Finish (Next are the Rail Installs)

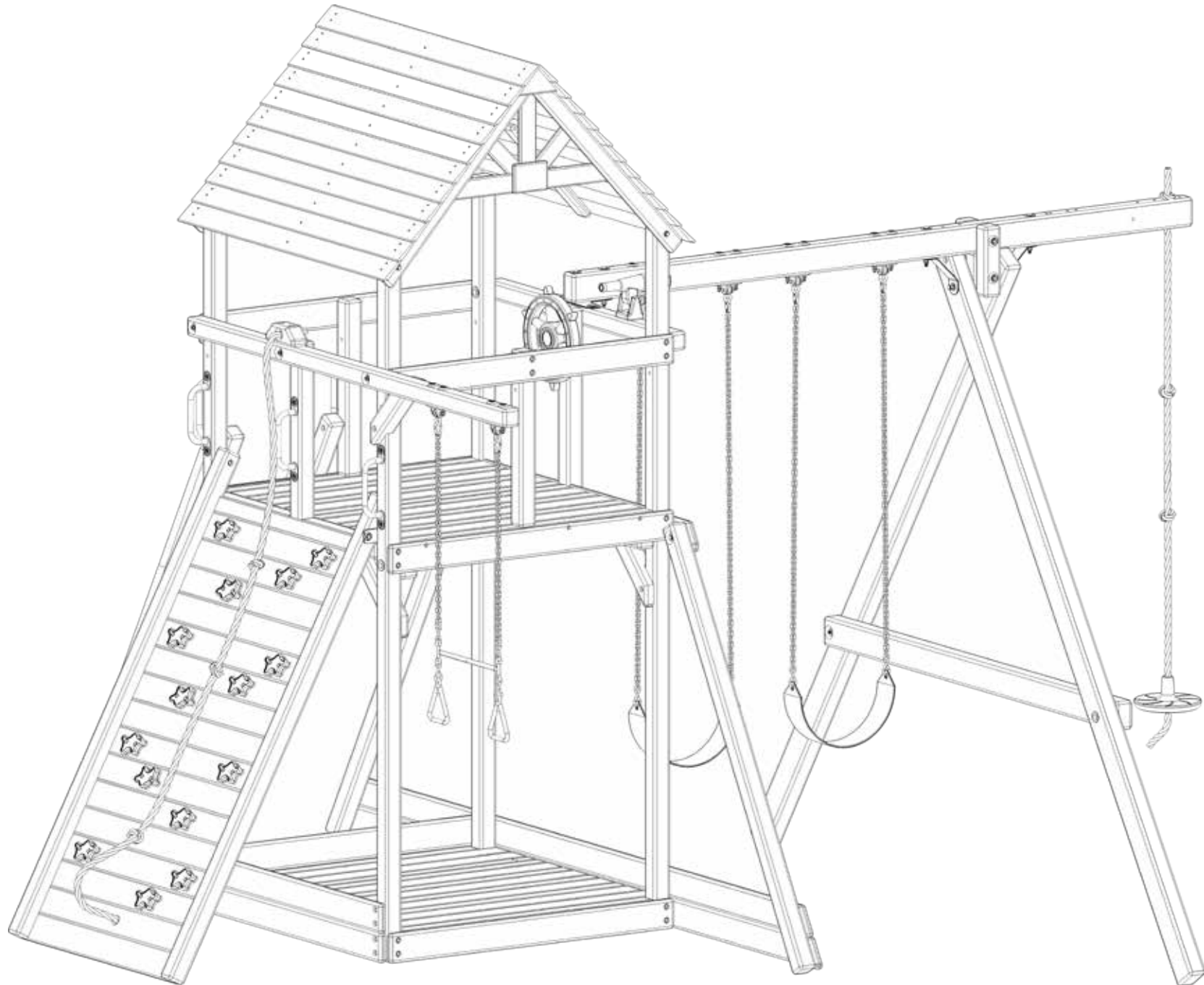

Open Rail Install

PARTS NEEDED

CC-088- 27 1/2" Rail Spindle-	(20)
CC-099- 25" Rail Top-	(4)
CC-100- 25" Rail Bottom-	(4)

HARDWARE NEEDED

D- 2 1/2" Coated Deck Screw-	(80)
N- 1/4" USS Flatwasher-	(16)
G- 1/4" x 4 1/2" Hex Lag Screw-	(8)
F- 1/4" x 3" Hex Lag Screw-	(8)

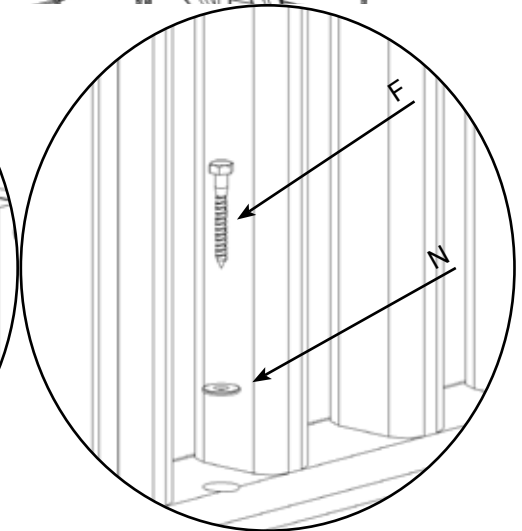
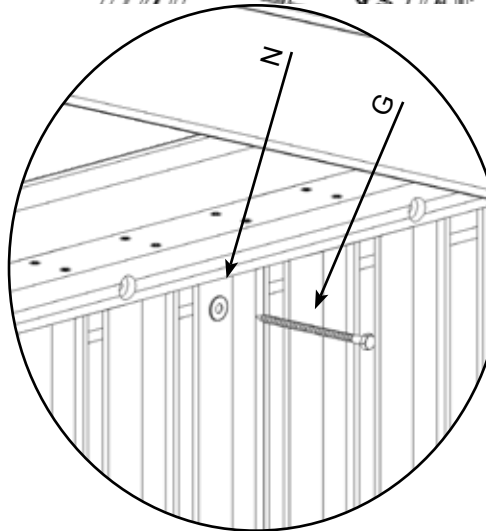
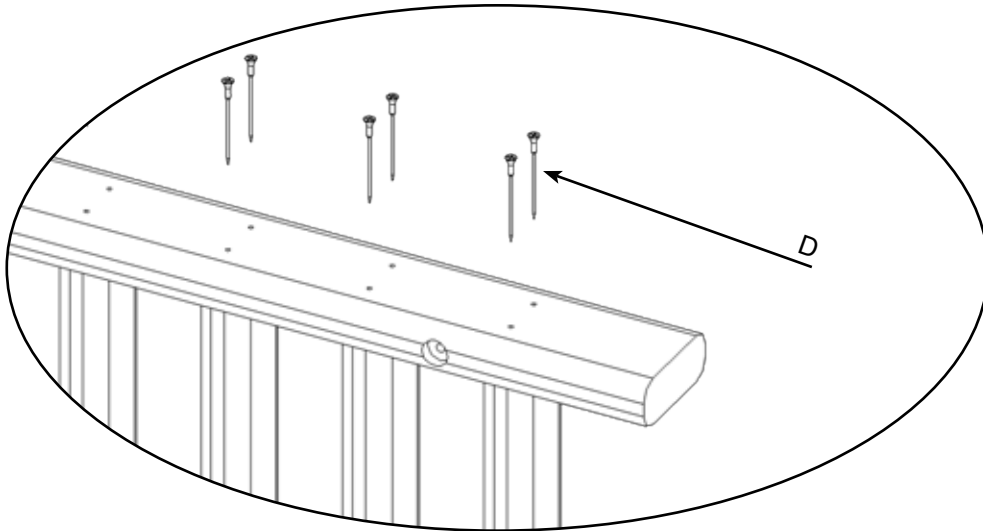
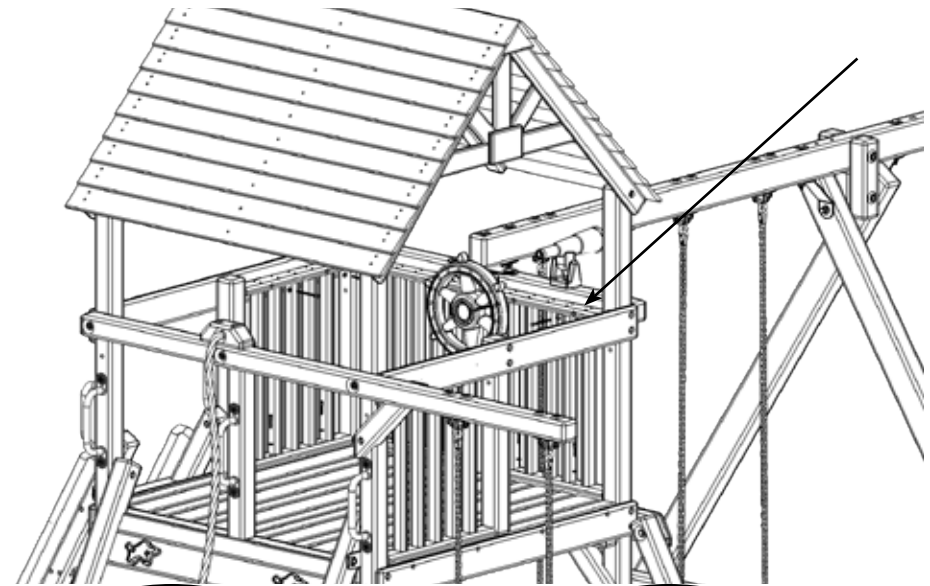
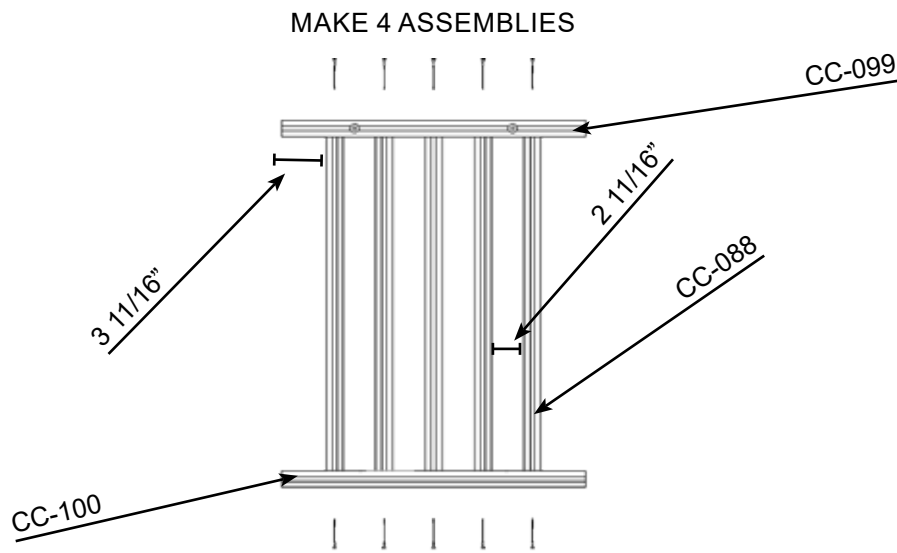

Open Rail Install

PARTS NEEDED

Slide-

(1)

HARDWARE NEEDED

J- #14 x 2" Pan Phillips T/S-

(3)

N- 1/4" USS Flatwasher-

(3)

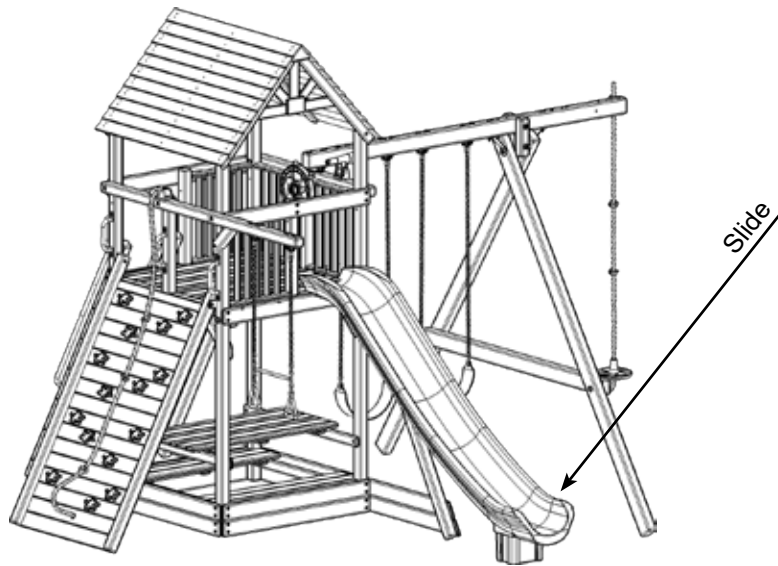

FINISHED OPEN RAIL ASSEMBLY WITH PICNIC TABLE

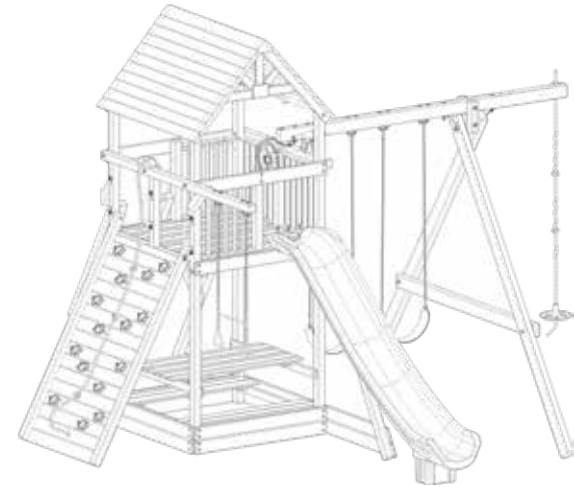

FINISHED OPEN RAIL ASSEMBLY WITH LOWER FLOOR

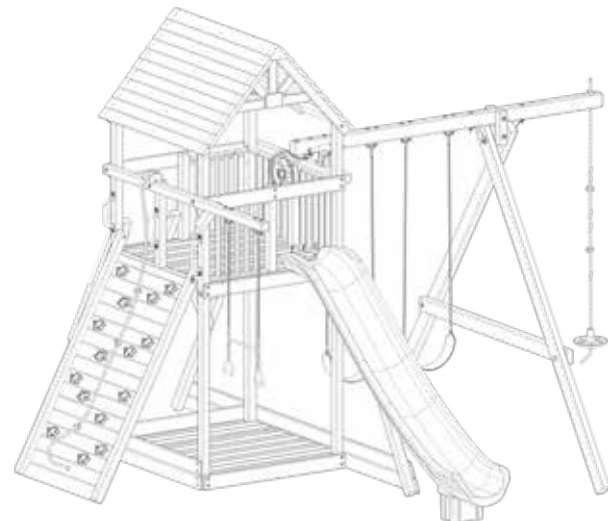
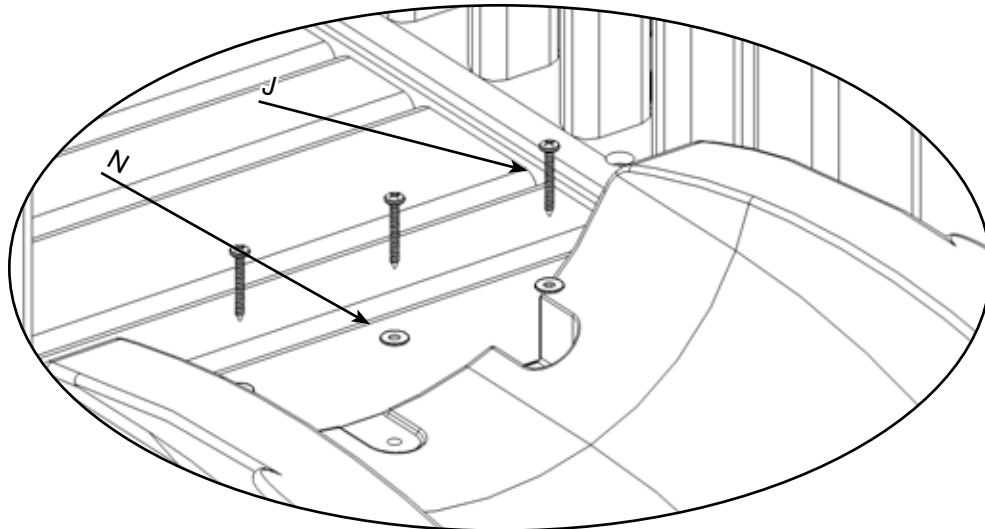

Closed Rail Install (Used For Treehouse Install)

PARTS NEEDED

CC-088- 27 1/2" Rail Spindle-	(20)
CC-099- 25" Rail Top-	(4)
CC-100- 25" Rail Bottom-	(4)
CC-089- 27 1/2" Panel Filler-	(16)
CC-001- 24 13/16" Panel Filler Support-	(8)

HARDWARE NEEDED

D- 2 1/2" Coated Deck Screw-	(16)
TP-1- 1 5/8" Coated Deck Screw-	(144)

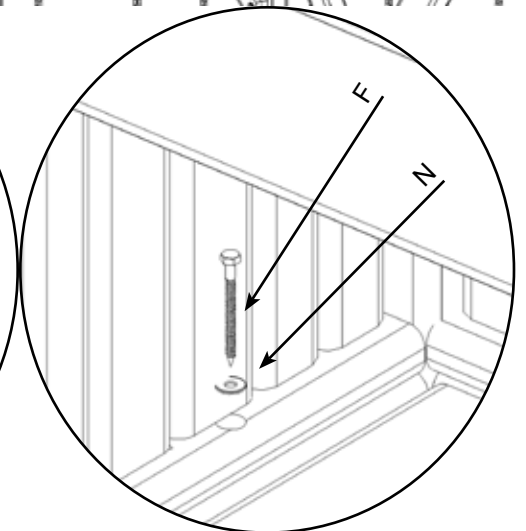
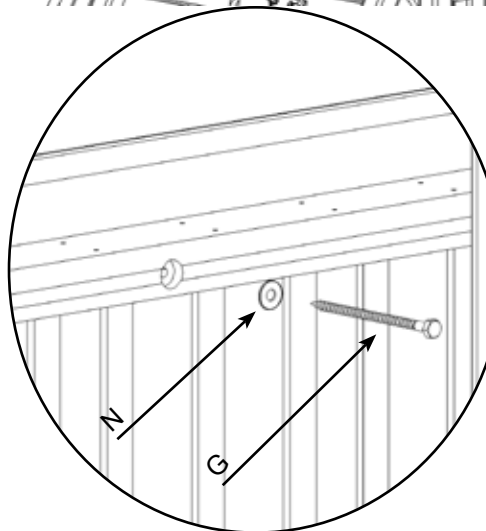
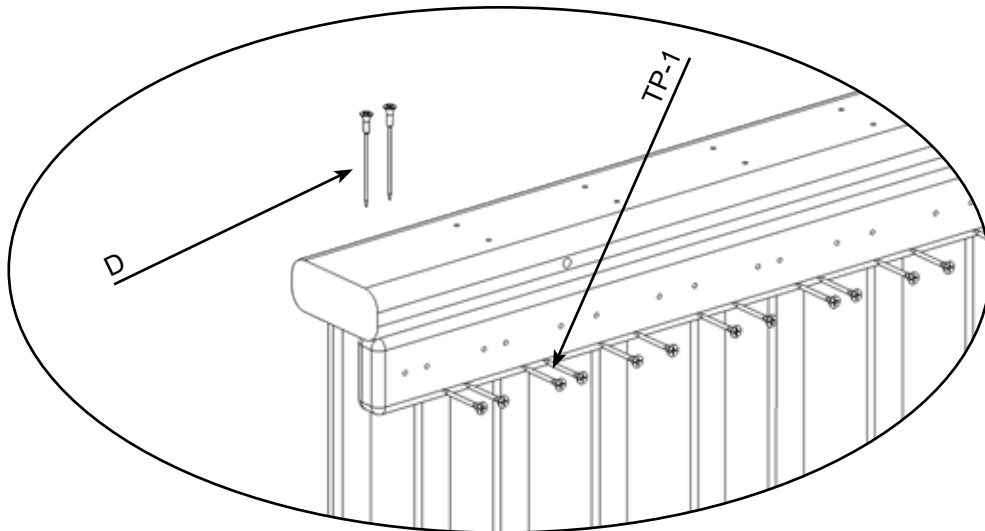
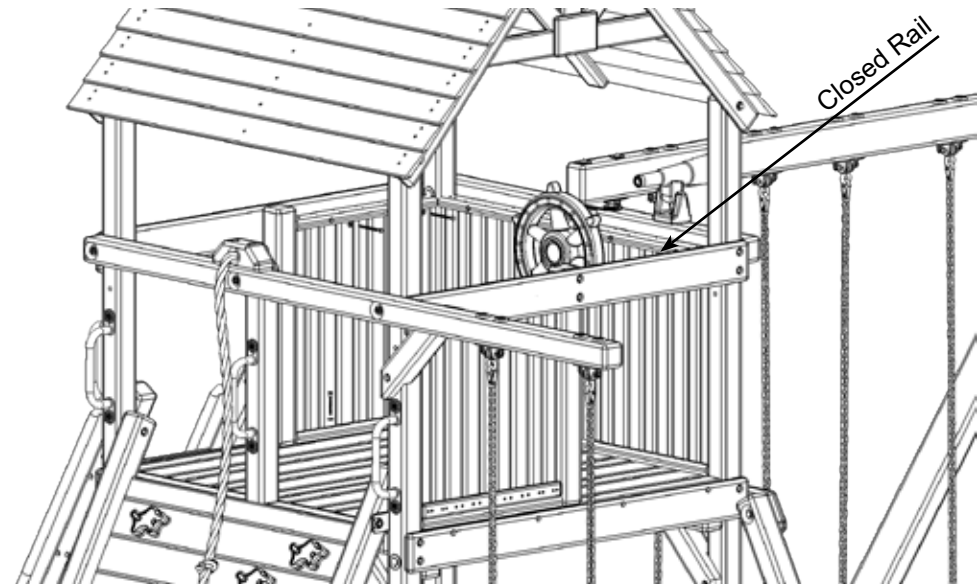
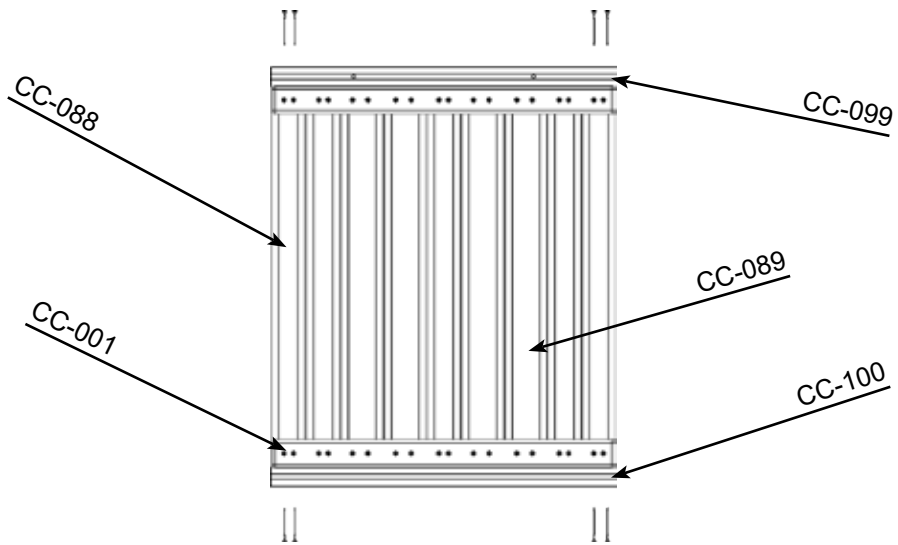

Closed Rail Install (Used For Treehouse Install)

PARTS NEEDED

Slide-

(1)

HARDWARE NEEDED

J- #14 x 2" Pan Phillips T/S-

(3)

N- 1/4" USS Flatwasher-

(3)

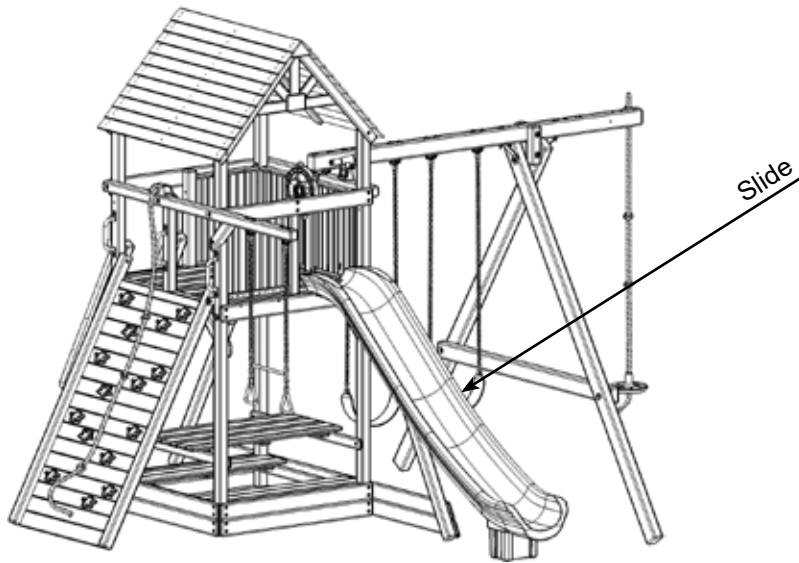

FINISHED CLOSED RAIL ASSEMBLY WITH PICNIC TABLE

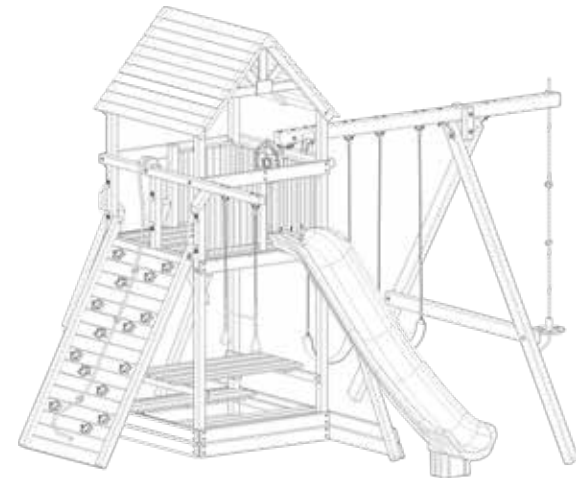

FINISHED CLOSED RAIL ASSEMBLY WITH LOWER FLOOR

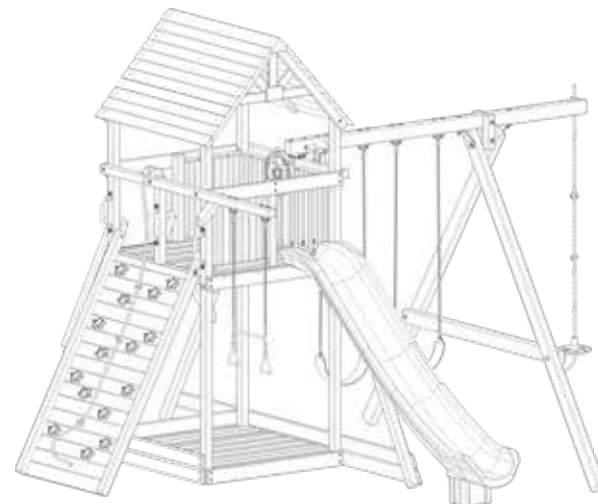
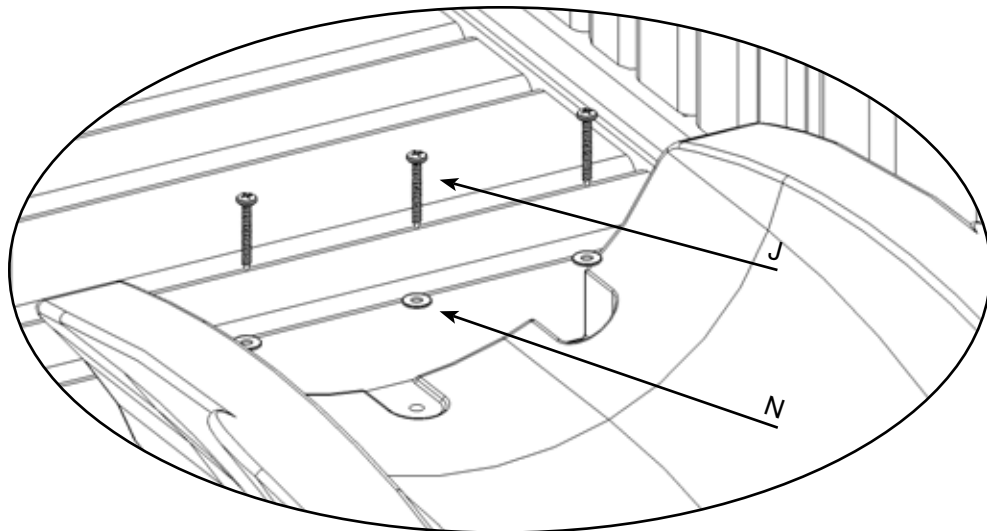

Playhouse Door Panel Assembly

PARTS NEEDED

408-9- 12 7/8" Upper Door Filler-	(3)	408-27- 63 11/16" Door Large Board-	(2)
408-13- 30 3/8" Under Window Filler-	(3)	408-2- 63 11/16" Slim Door Board-	(2)
CC-018- 24 1/2" Door Cross Piece-	(2)	CC-016- 20" Playhouse Window Arch-	(1)
408-21- 17" Playhouse Left Shutter-	(1)	408-22- 17" Playhouse Right Shutter-	(1)
CC-048- 24 1/2" Large Door Bottom Angled-	(1)		

HARDWARE NEEDED

PP-2- 1 5/8" Coated Deck Screw-	(40)
---------------------------------	------

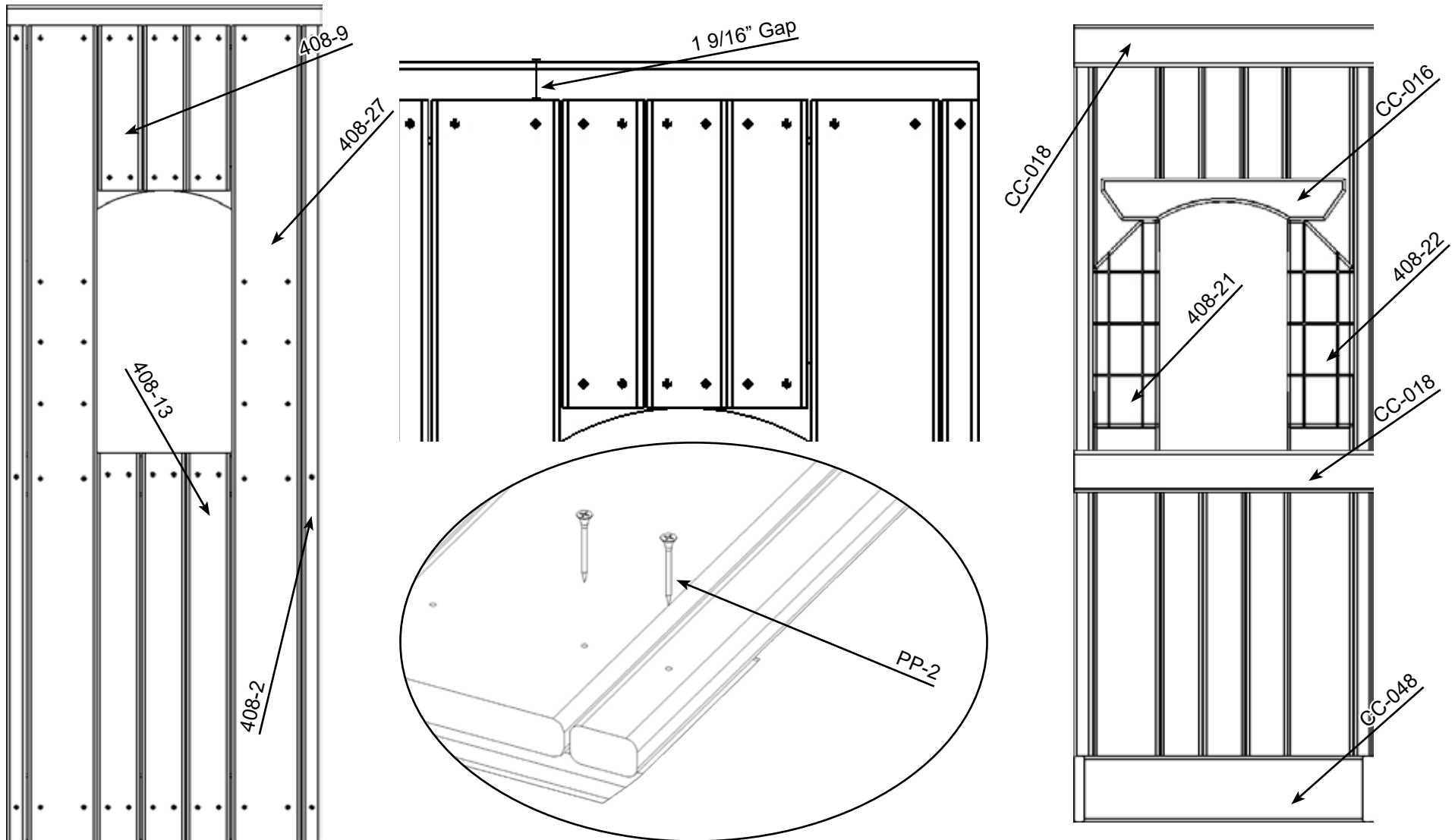

Door Side Panel

PARTS NEEDED

408-29- 65 5/8" Shutter Board-	(2)	408-16- 14" Above Window Filler Door Side-	(4)
408-17- 30 3/8" Lower Door Side Filler-	(4)	CC-027- 32 1/8" Door Side Cross Facia-	(2)
408-21- 17" Playhouse Left Shutter-	(1)	408-22- 17" Playhouse Right Shutter-	(1)
CC-016- 20" Playhouse Window Arch-	(1)	CC-049- 32 1/8" Large Lower Door Side Crosspiece-	(1)

HARDWARE NEEDED

PP-2- 1 5/8" Coated Deck Screw-	(56)
---------------------------------	------

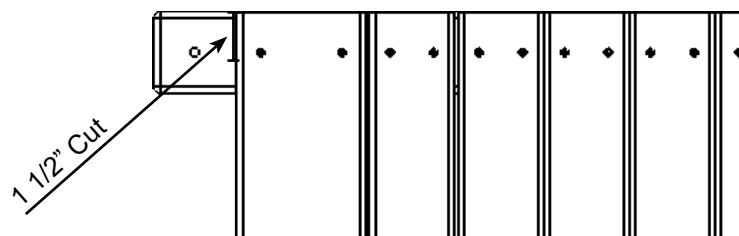
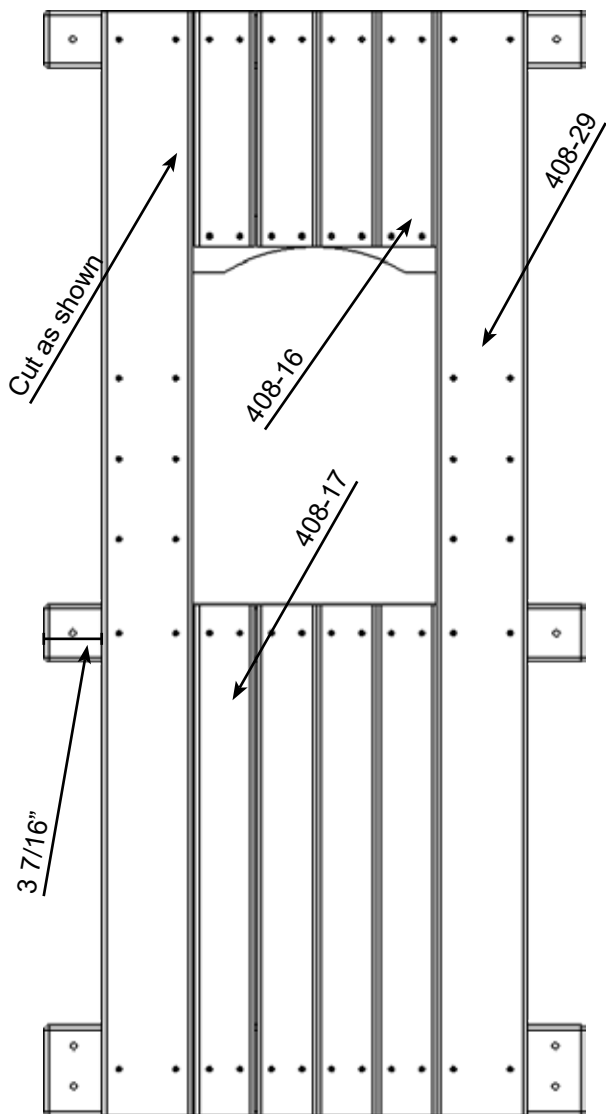

THE SHUTTER BOARD THAT WILL BE UNDER THE MAINBEAM NEEDS 1 1/2" CUT OFF THE TOP OF THE BOARD

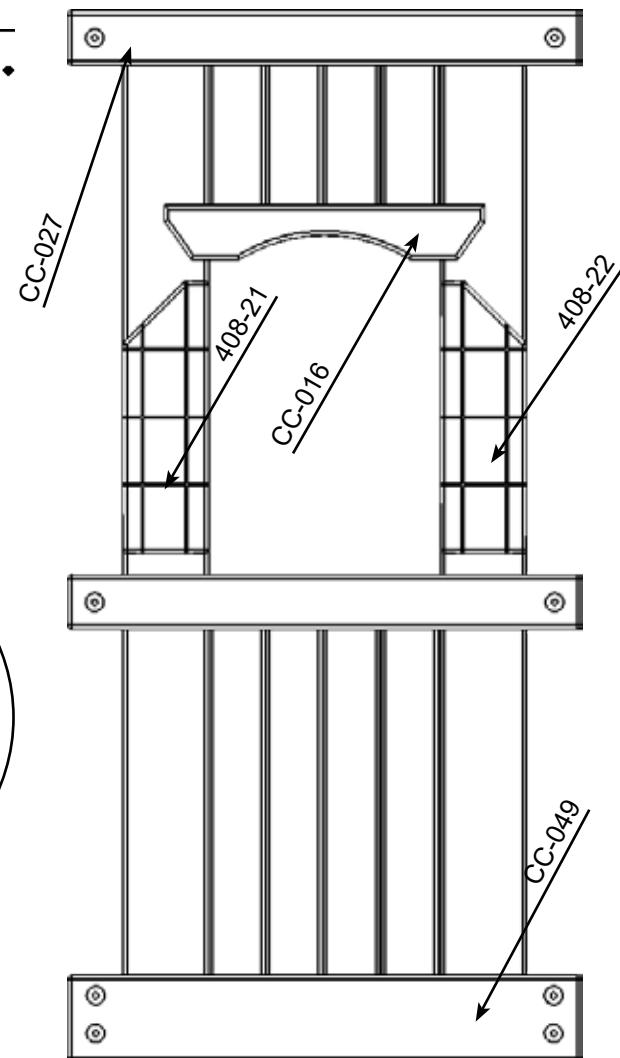
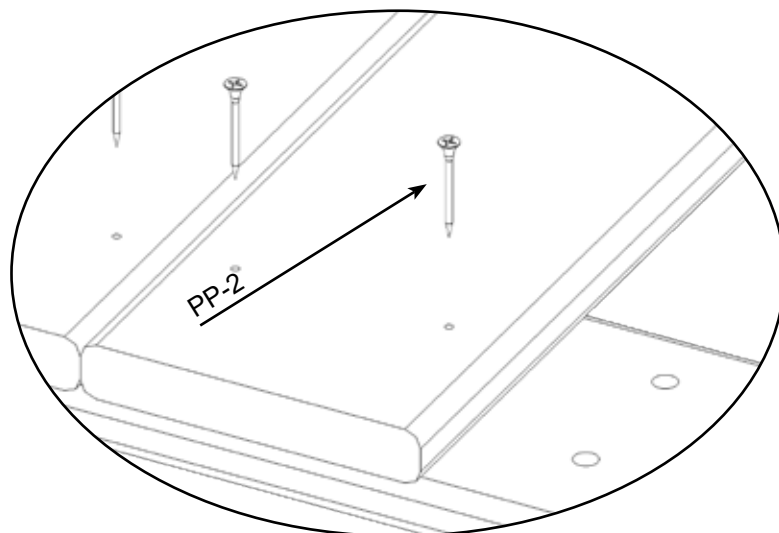

Playhouse Store Assembly

PARTS NEEDED

408-15- 64 1/8" Store End Board-	(2)	408-18- 14" Upper Store Center Filler-	(1)
408-10- 14" Above Window Filler-	(6)	408-20- 14" Store Upper Wide Filler-	(2)
CC-050- 35 1/4" Playhouse Store Couter-	(1)	408-13- 30 3/8" Under Window Filler-	(6)
408-19- 30 3/8" Store Lower Center Filler-	(1)	408-24- 30 3/8" Playhouse Under Store Wide Board-	(2)
CC-040- 60 3/4" Store Cross Facia-	(2)	408-21- 17" Playhouse Left Shutter-	(1)
408-22- 17" Playhouse Right Shutter-	(1)	CC-030- 44 1/2" Store Arch-	(1)
CC-108-35" Store Counter Support-	(1)		

HARDWARE NEEDED

(1)	PP-2- 1 5/8" Coated Deck Screw-	(78)
(2)	PP-3- 2" Coated Deck Screw-	(4)

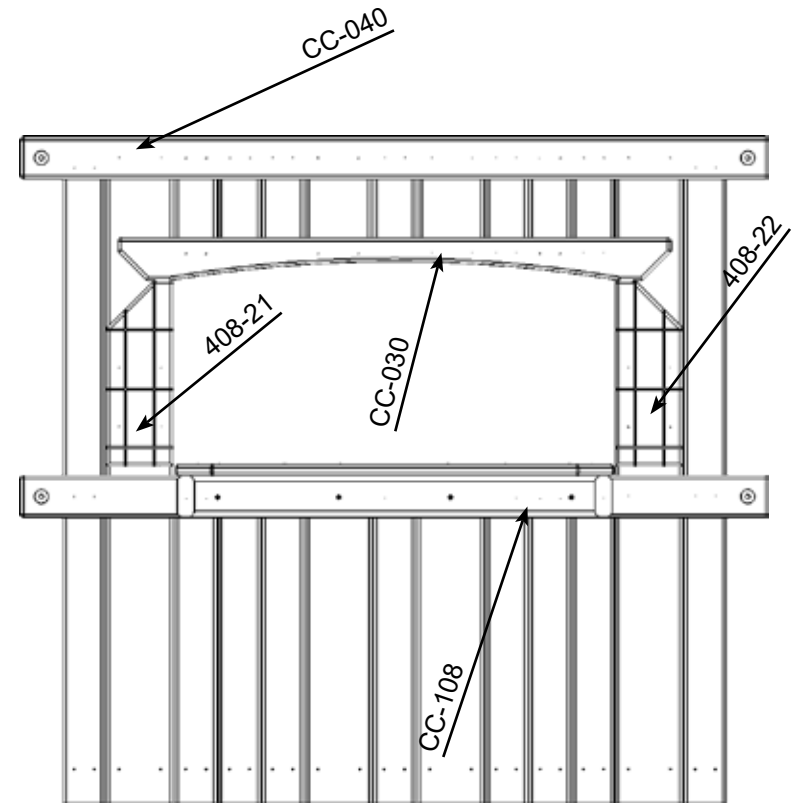
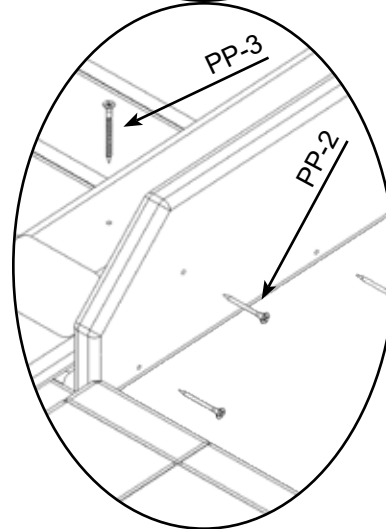
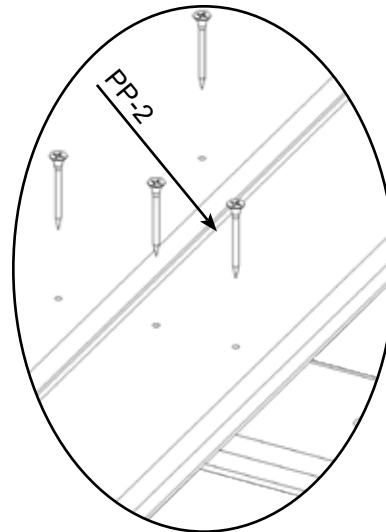
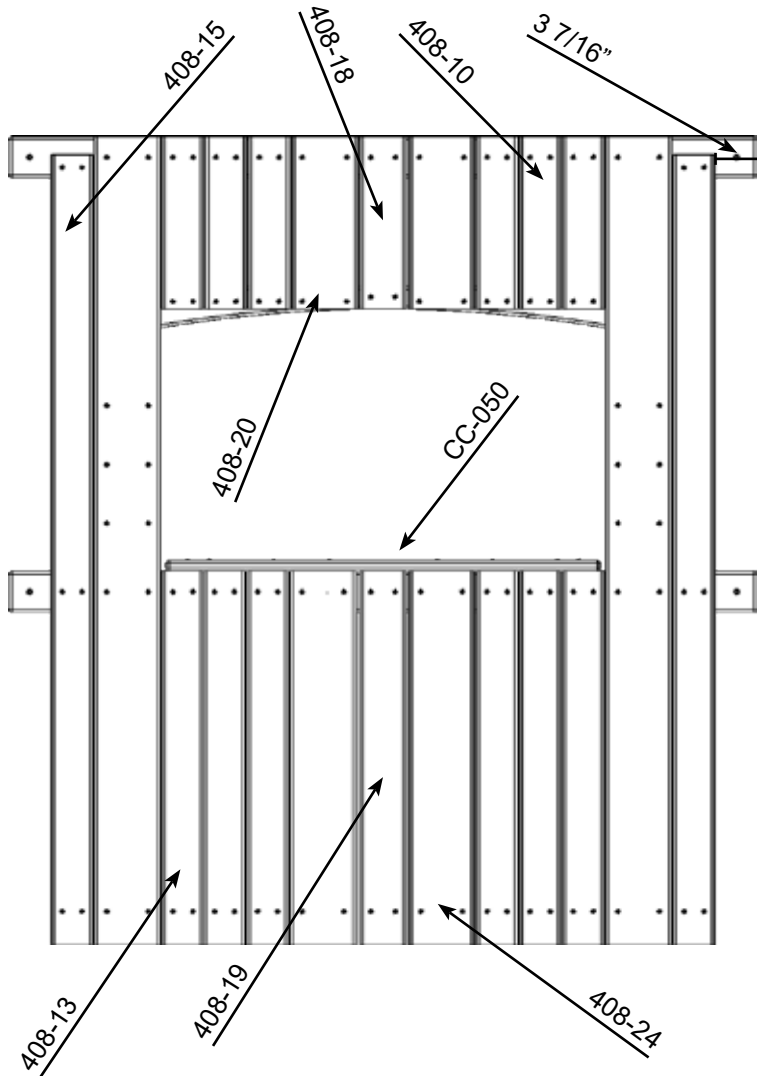

Rockwall Side Panel

PARTS NEEDED

408-29- 65 5/8" Shutter Board-	(2)	408-10- 14" Above Window Filler-	(8)
408-13- 30 3/8" Under Window Filler-	(8)	408-4- 64 1/8" Center Playhouse Panel Board-	(1)
CC-016- 20" Playhouse Window Arch-	(2)	408-21- 17" Playhouse Left Shutter-	(1)
408-22- 17" Playhouse Right Shutter-	(1)	CC-037- 60 1/4" Side Cross Facia-	(2)

HARDWARE NEEDED

PP-2- 1 5/8" Coated Deck Screw-	(94)
---------------------------------	------

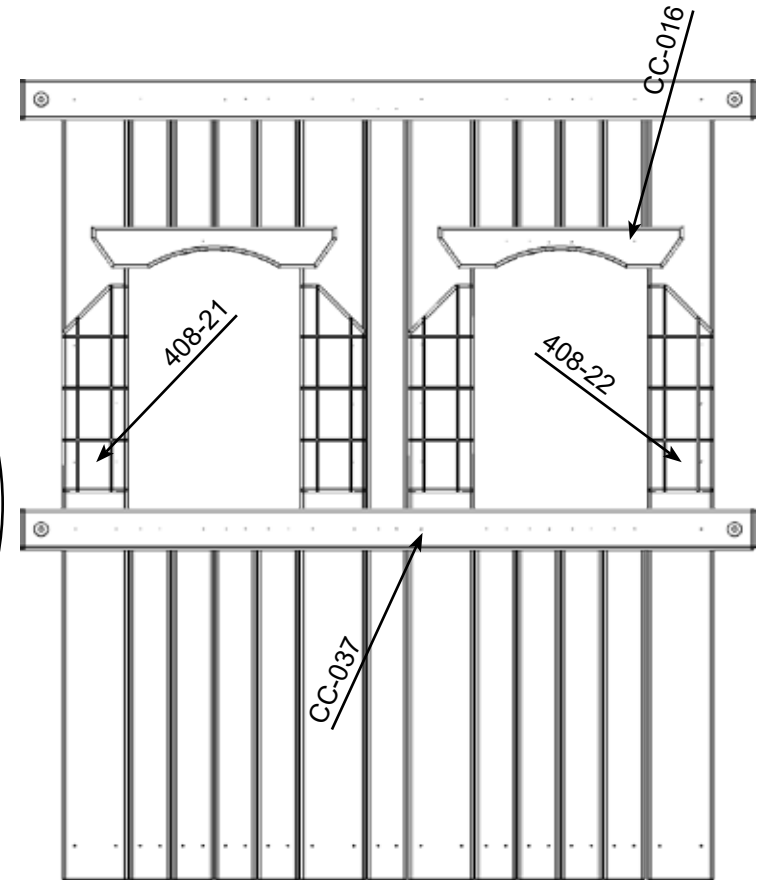
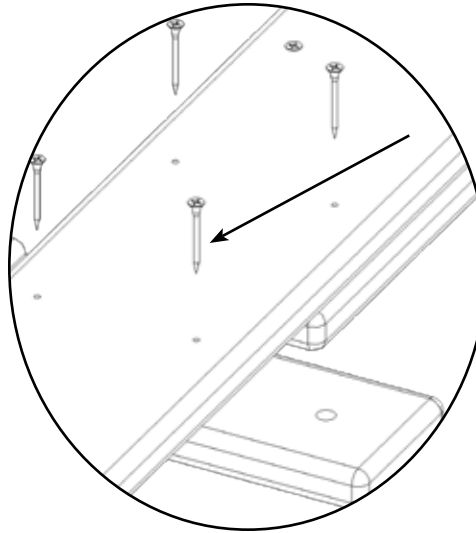
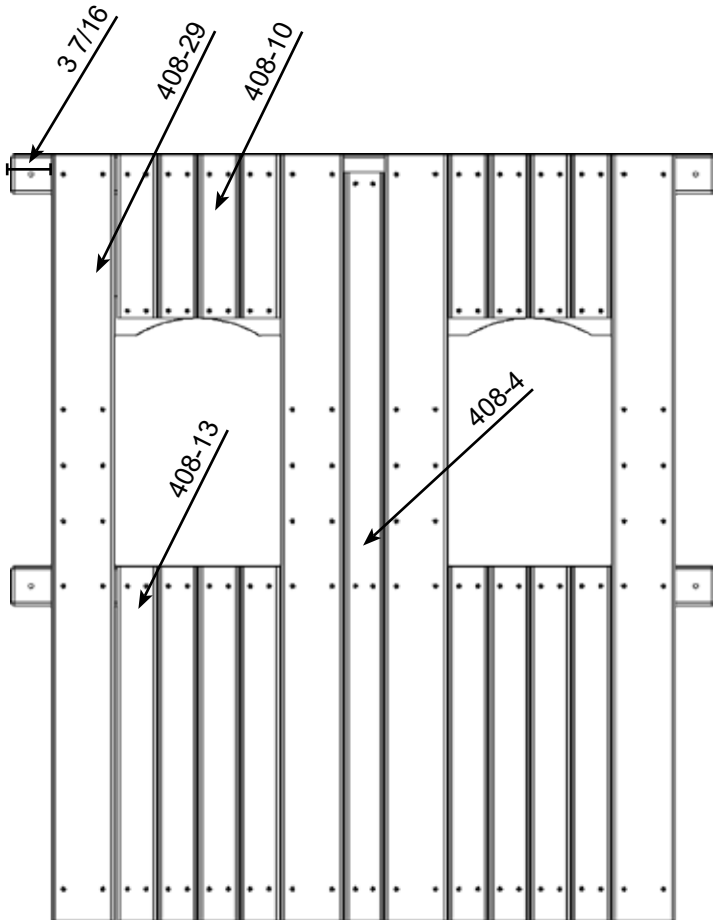

Wing Side Panel

PARTS NEEDED

408-28- 64 1/4" Shutter Board Wing Side-	(4)	408-9- 12 7/8" Upper Door Filler-
408-3- 62 3/4" Center Wing Side Board-	(1)	CC-037- 60 1/4" Side Cross Facia-
408-21- 17" Playhouse Left Shutter-	(1)	408-22- 17" Playhouse Right Shutter-

HARDWARE NEEDED

(8)	PP-2- 1 5/8" Coated Deck Screw-	(92)
(2)		
(1)		

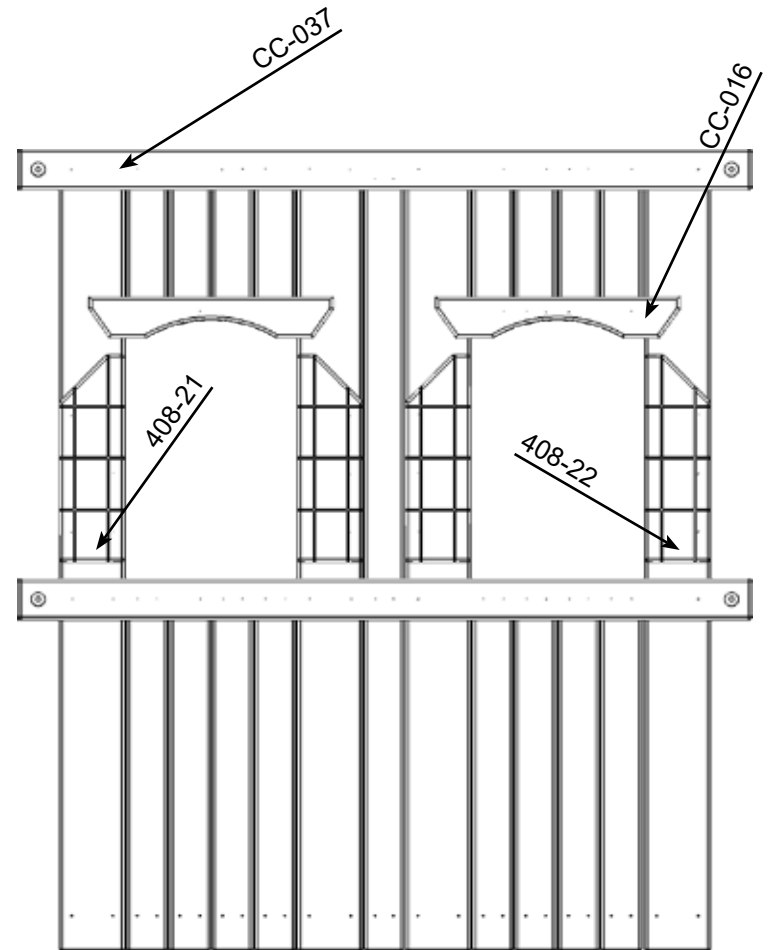
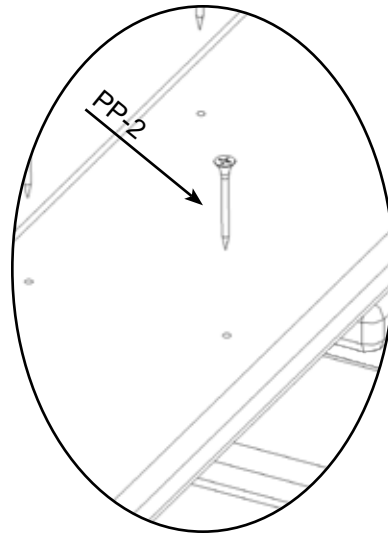
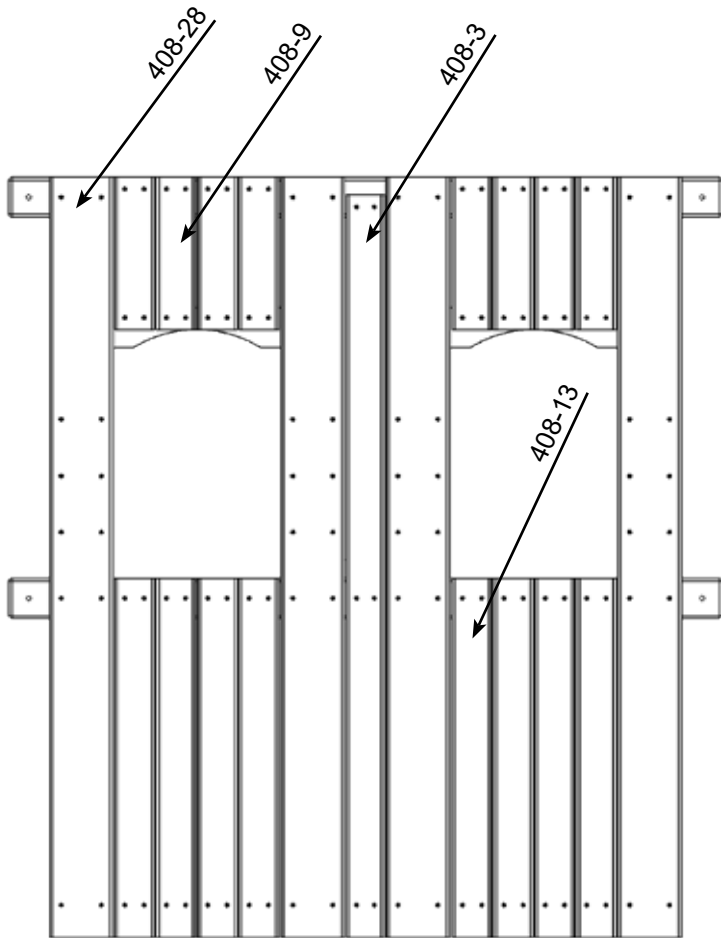

Playhouse Panel Install

PARTS NEEDED

Wing Side Panel-
Store Panel-

(1)
(1)

HARDWARE NEEDED

PP-7- 3/8" USS Flatwasher-
PP-4- 3/8" x 3 1/2" Hex Lag Screw-
PP-2- 1 5/8" Coated Deck Screw-

(8)
(8)
(52)

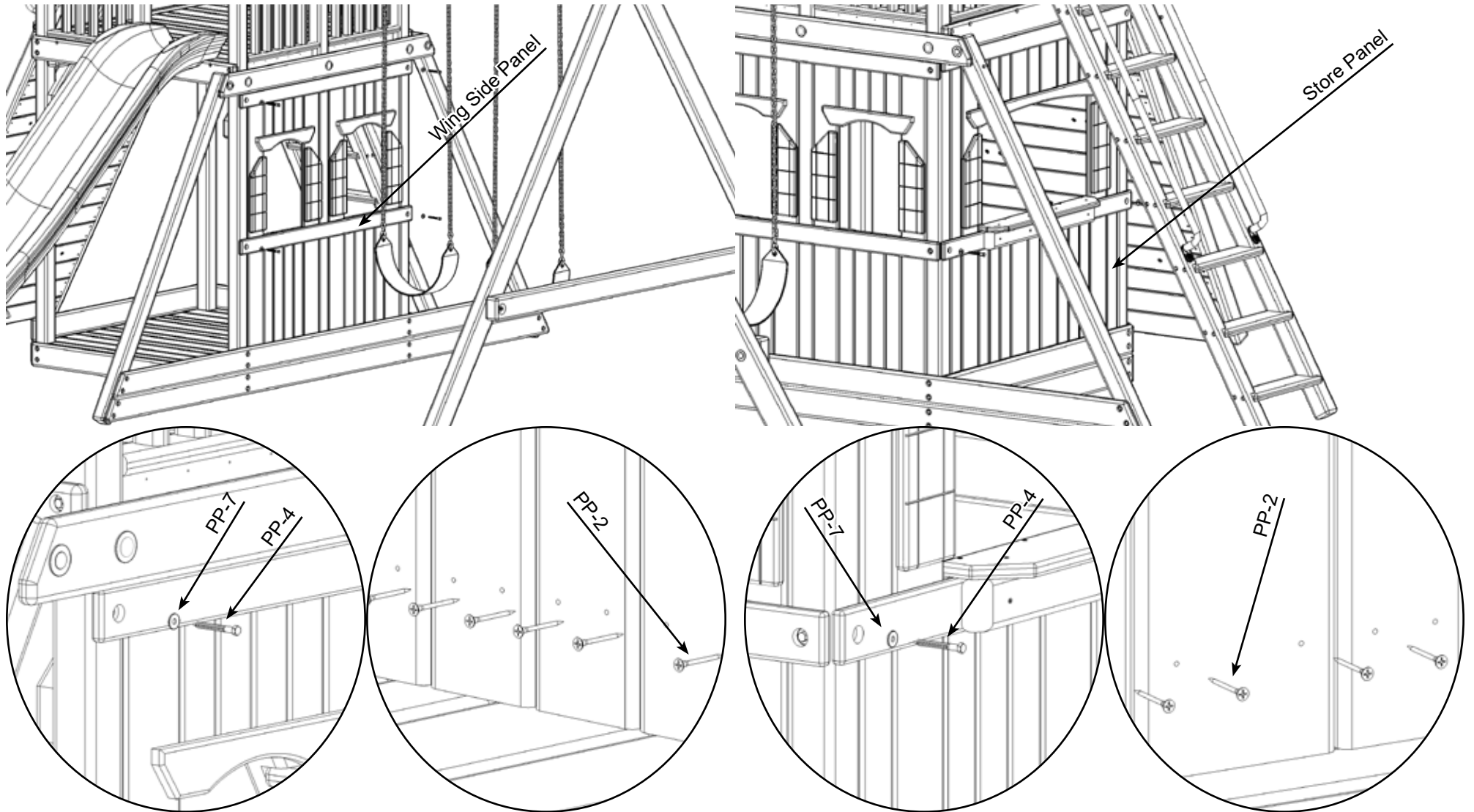

Playhouse Panel Install

PARTS NEEDED

Rockwall Side Panel-
Door Side Panel-

(1)
(1)

HARDWARE NEEDED

PP-4- 3/8" x 3 1/2" Hex Lag Screw- (12)
 PP-7- 3/8" USS Flatwasher- (12)
 PP-2- 1 5/8" Coated Deck Screw- (26)
 PP-1- 90 Degree Bracket- (2)
 PP-6- 1/4" USS Flatwasher- (4)
 PP-5- #14 x 1" Pan Phillips T/S- (4)

ROCKWALL REMOVED FOR VISUAL PURPOSES

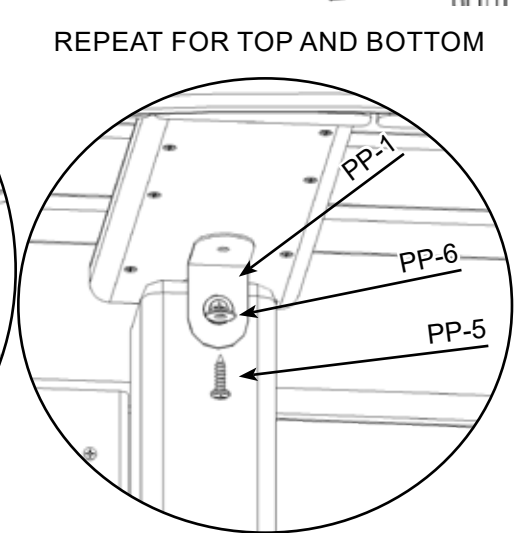
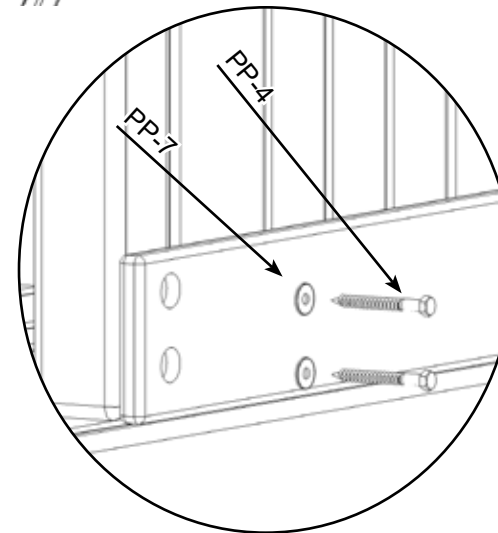
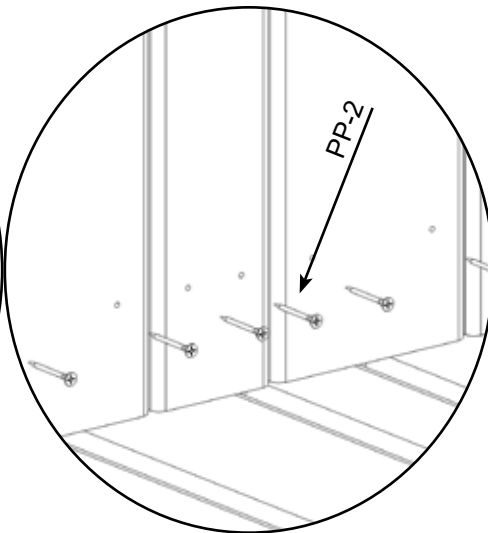
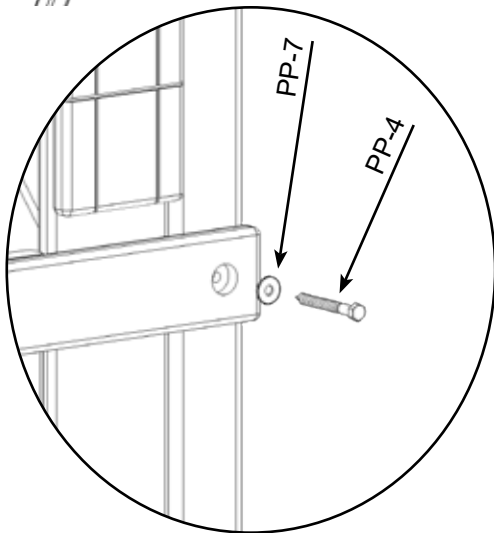
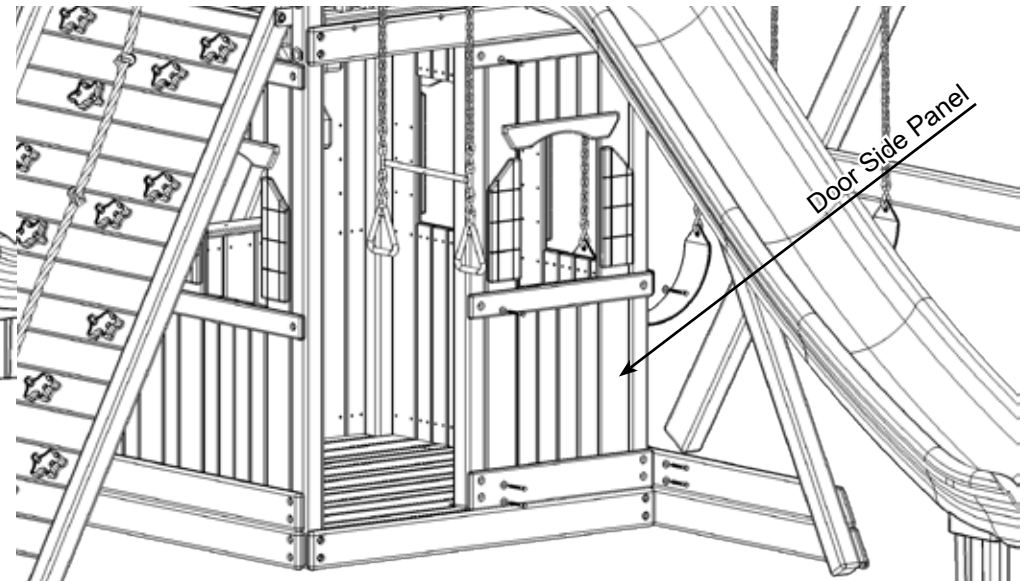
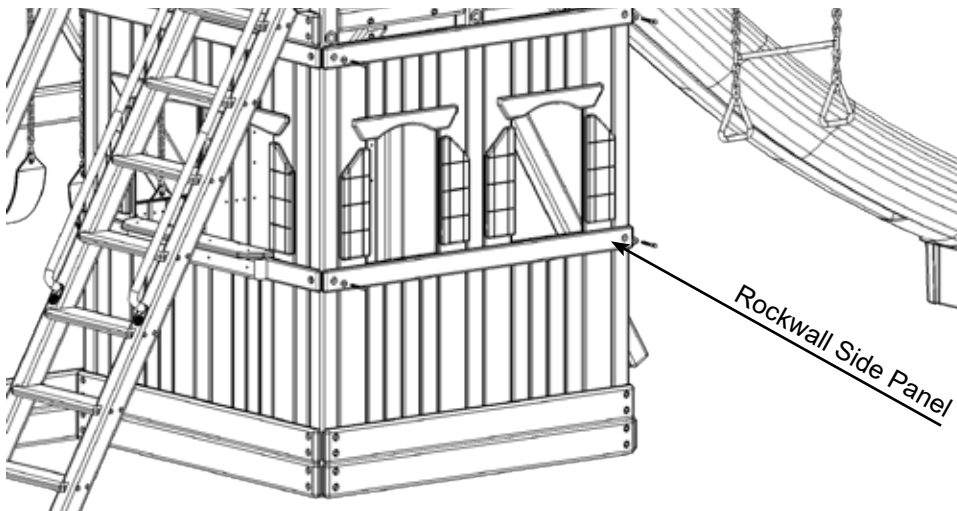

REPEAT FOR TOP AND BOTTOM

Playhouse Panel Install

PARTS NEEDED

408-1- 63 1/16" Door Stop-
Door Panel-

(1)
(1)

HARDWARE NEEDED

PP-2- 1 5/8" Coated Deck Screw-
PP-8- Hinges-
PP-5- #14 x 1" Pan Phillips T/S-

(4)
(2)
(12)

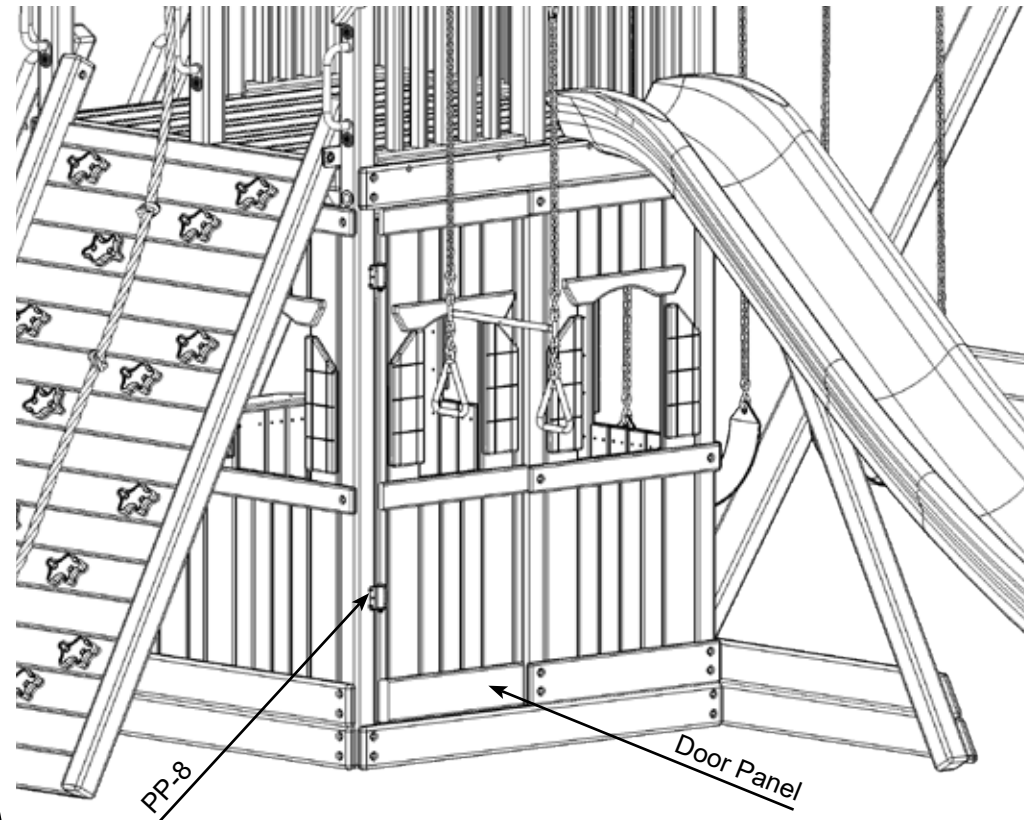
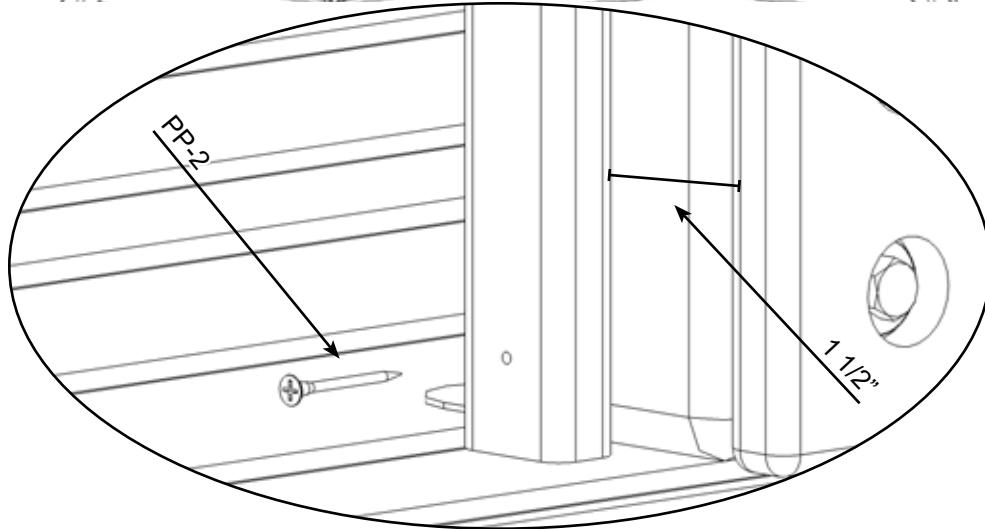
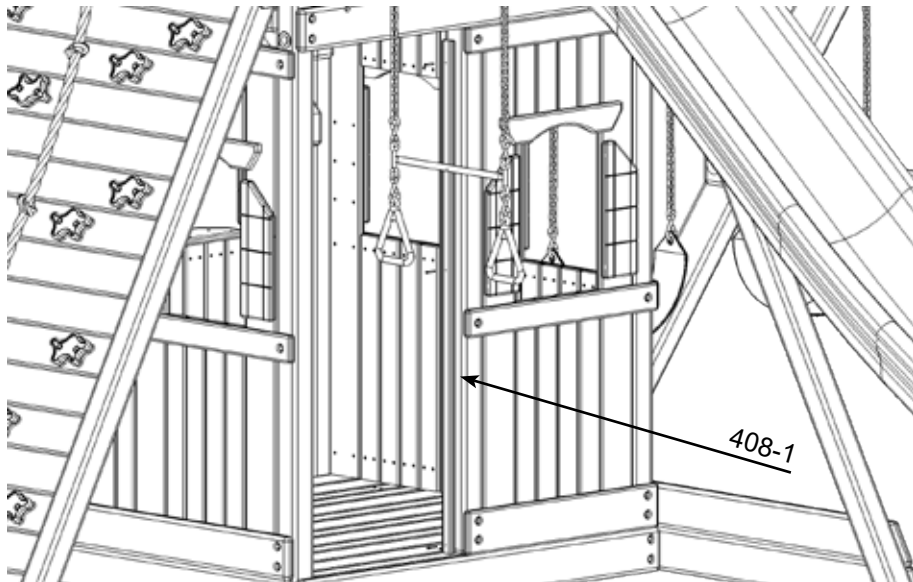

PLACE THE PP-8 HINGES ON THE DOOR WITH THE PP-5- #14 X 1" PAN PHILLIPS T/S AND ATTACH TO THE CORNER POST.

Playouse Panel Install

PARTS NEEDED

- PP-8- Handle- (1)
- CC-005- 6" Door Knob Plate- (1)

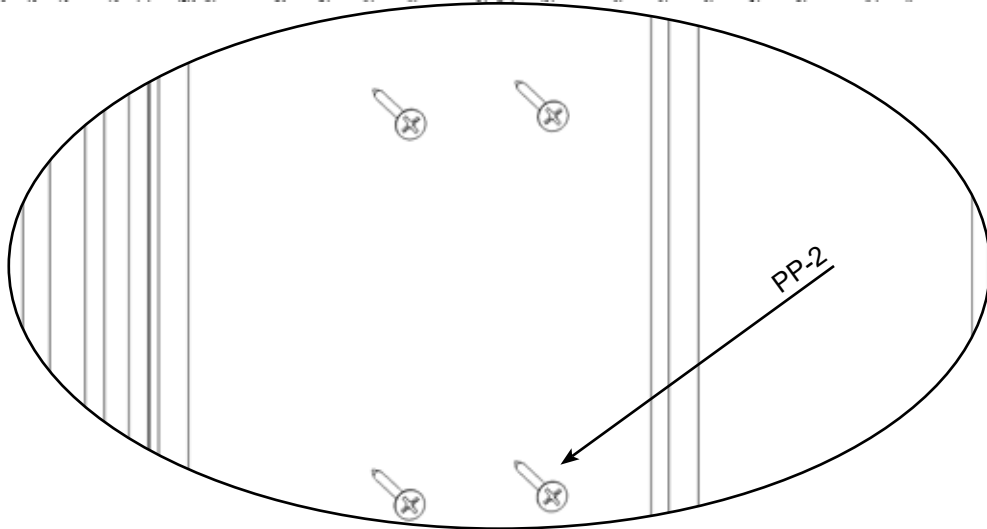
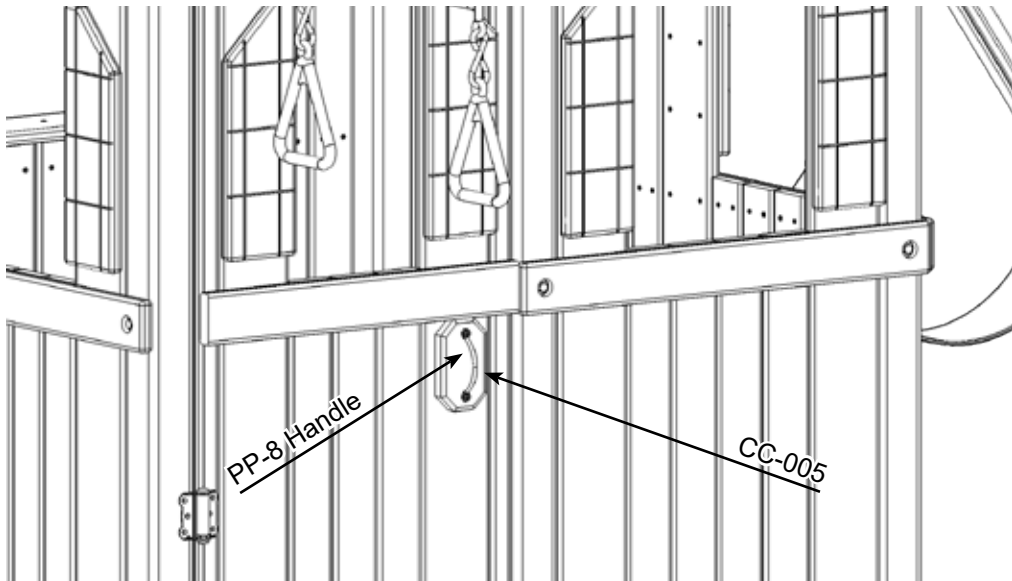

Playouse Panel Install Finish

HARDWARE NEEDED

- PP-2- 1 5/8" Coated Deck Screw- (4)

OPEN RAIL ASSEMBLY WITH PLAYHOUSE PANELS

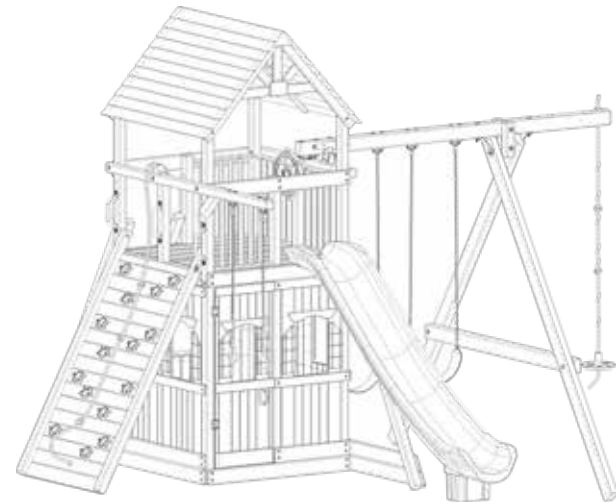

CLOSED RAIL ASSEMBLY WITH PLAYHOUSE PANELS



Rockwall Side Treehouse Panel

PARTS NEEDED

406-6- 19 1/2" Side Panel End Board-	(2)	406-5- 18" Side Center Panel Board-	(1)
406-4- 10 1/2" Side Center Holder-	(1)	406-18- 19 1/2" Side Shutter Board-	(4)
406-11- 60 1/4" Side Facia-	(1)	CC-057- 14" Side Left Shutter-	(2)
CC-058- 14" Side Right Shutter-	(2)		

HARDWARE NEEDED

TP-1- 1 1/2" Coated Deck Screw-	(36)
---------------------------------	------

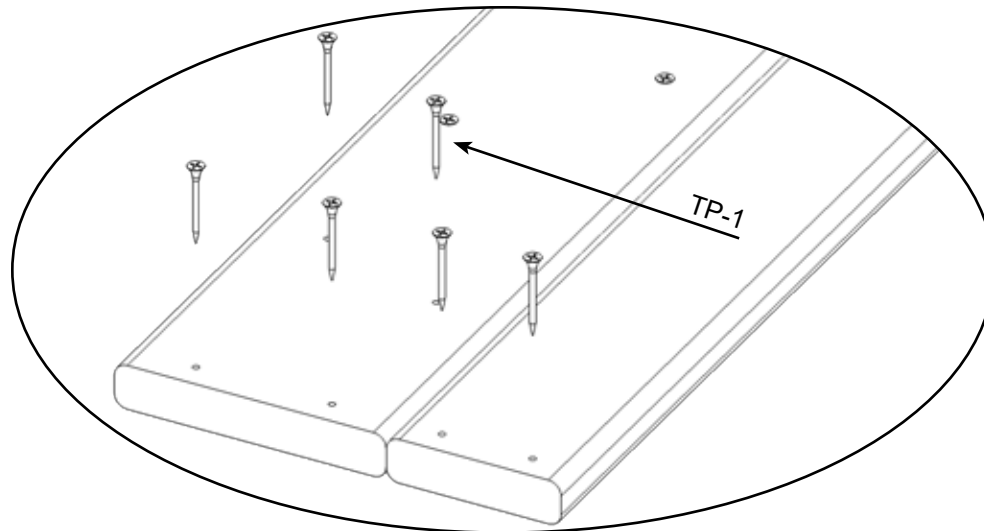
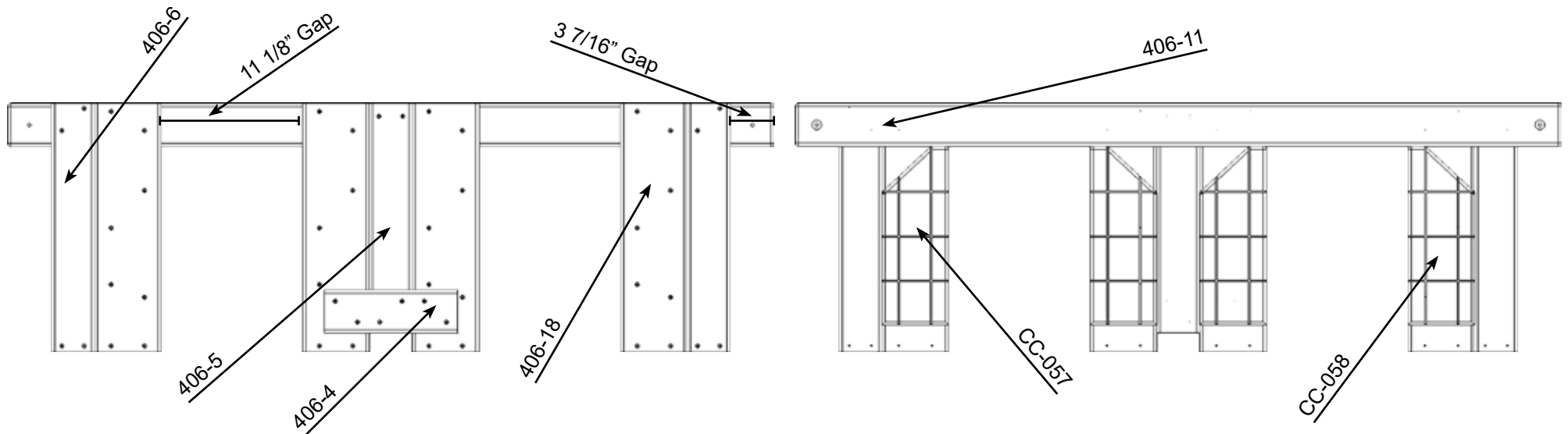

Swingbeam Side Treehouse Panel

PARTS NEEDED

406-6- 19 1/2" Side Panel End Board-	(2)	406-18- 19 1/2" Side Shutter Board-	(4)
406-4- 10 1/2" Side Center Holder-	(1)	406-5- 18" Side Center Panel Board-	(1)
CC-058- 14" Side Right Shutter-	(2)	CC-057- 14" Side Left Shutter-	(1)
406-13- 9 1/8" Left SB Side Shutter-	(1)	406-11- 60 1/4" Side Facia-	(1)

HARDWARE NEEDED

TP-1- 1 1/2" Coated Deck Screw-	(36)
---------------------------------	------

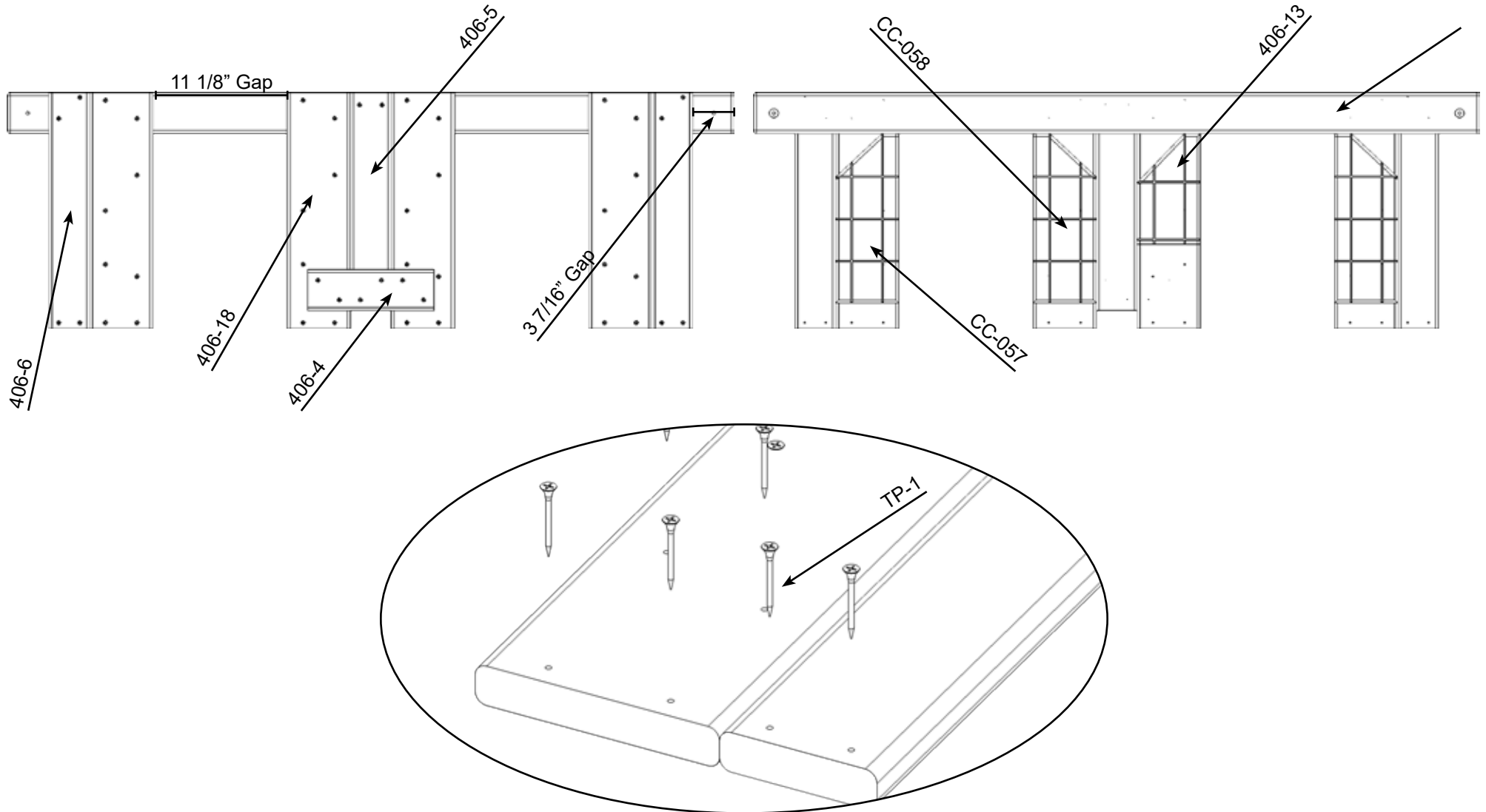

Treehouse Panel Install (Repeat for Both Sides)

PARTS NEEDED

- SB Side Panel- (1)
- RW Side Panel- (1)
- 406-8- 26 1/4" End Treehouse Panel Board- (4)

HARDWARE NEEDED

- TP-1- 1 1/2" Coated Deck Screw- (40)

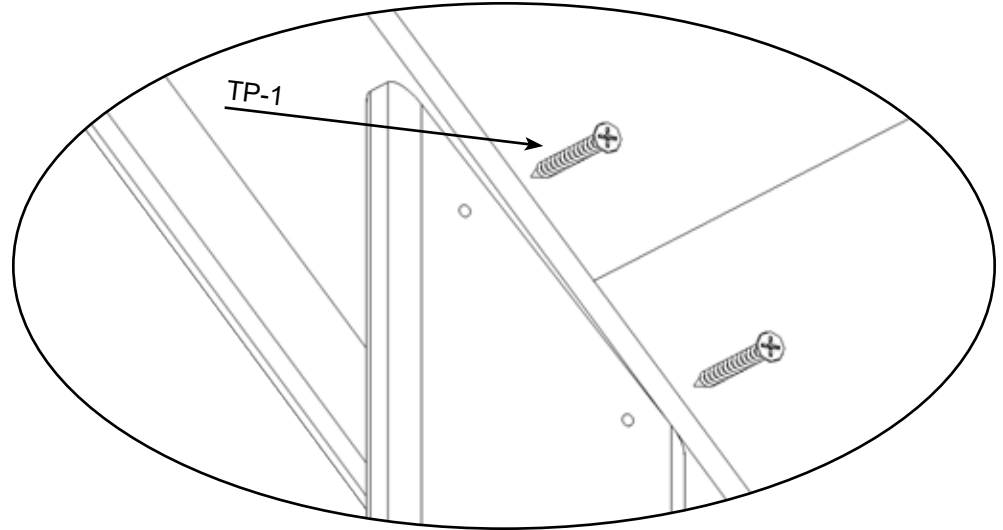
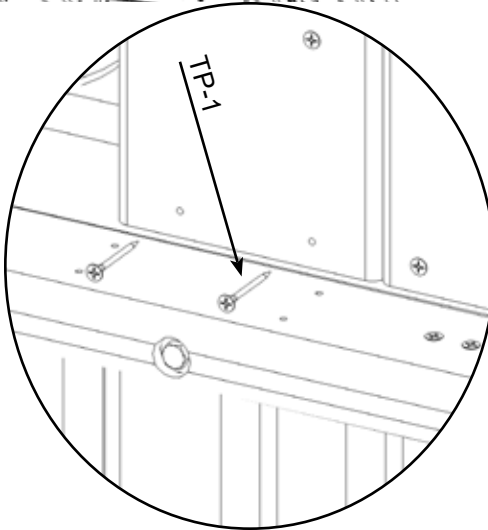
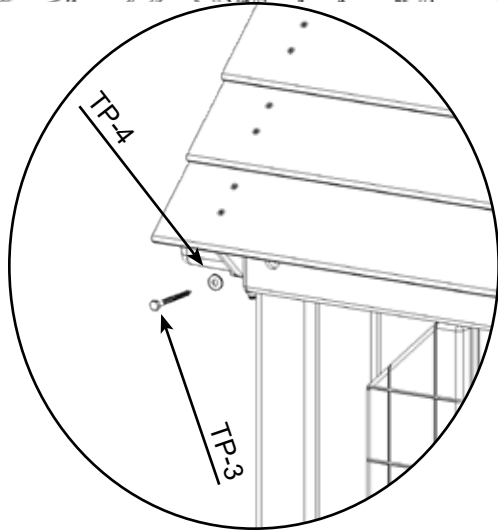
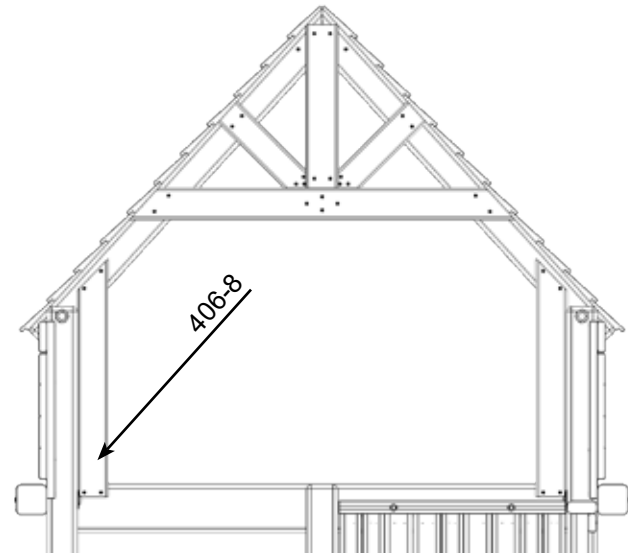
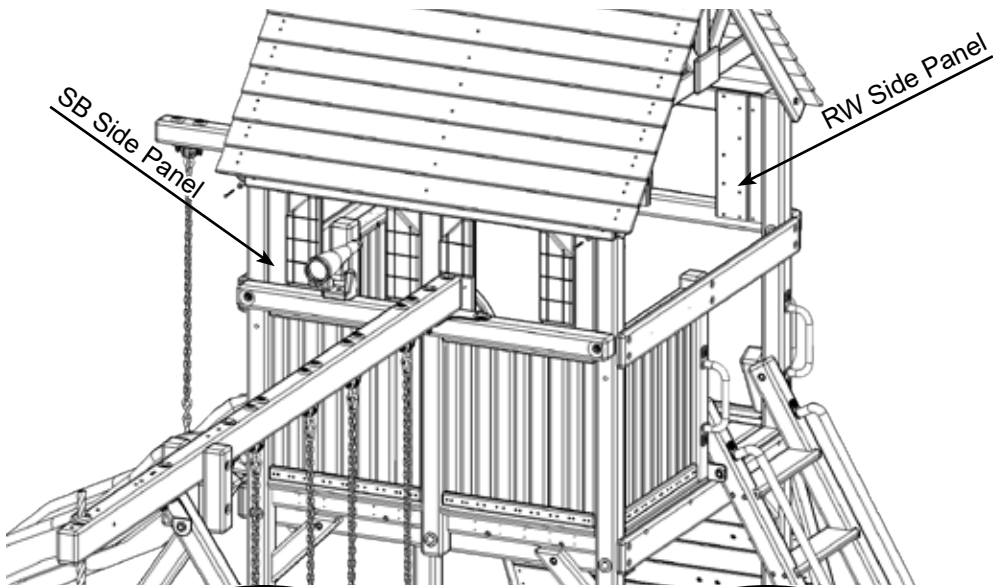

Treehouse Panel Install (Repeat for Both Sides)

PARTS NEEDED

- 406-20- 30 1/2" End Panel Board- (4)
- 406-10- 45 3/8" Panel Board #2- (2)

HARDWARE NEEDED

- TP-1- 1 1/2" Coated Deck Screw- (52)

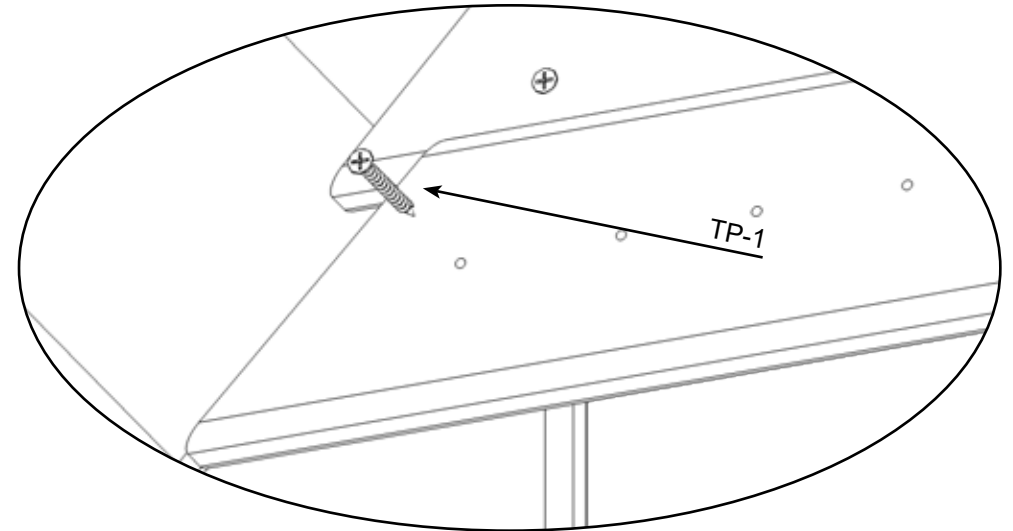
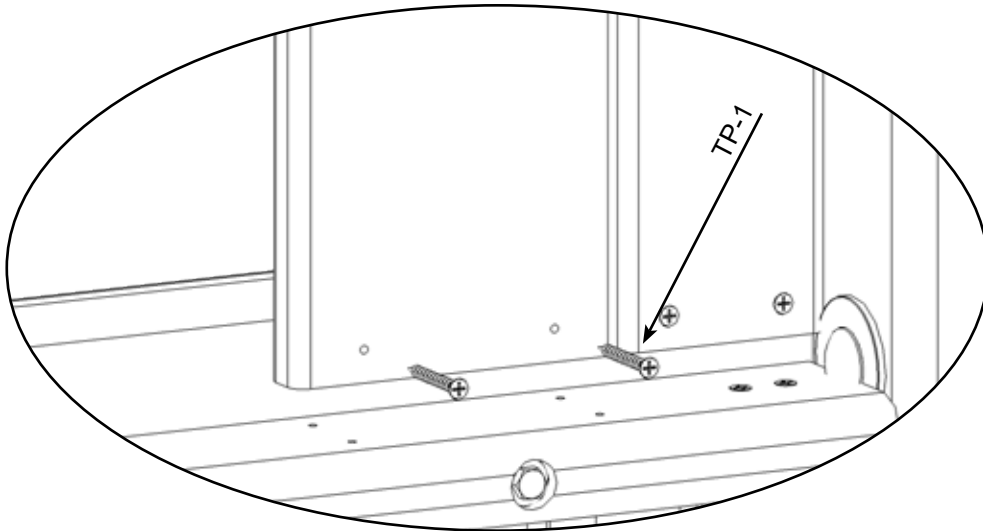
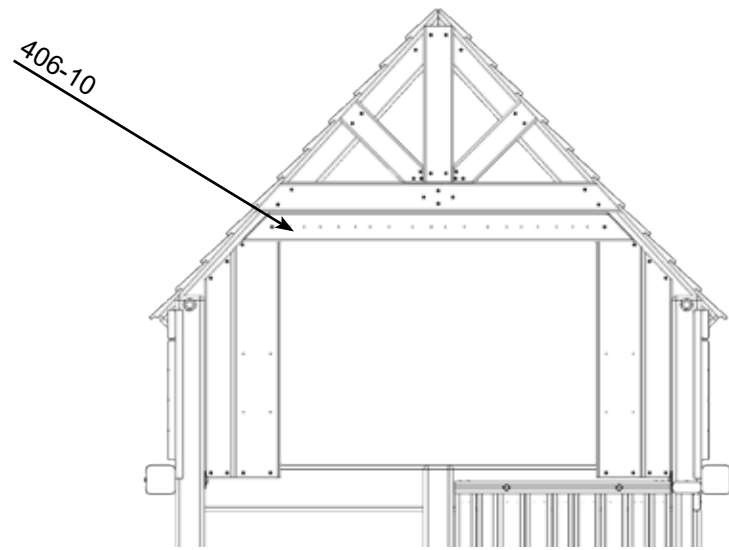
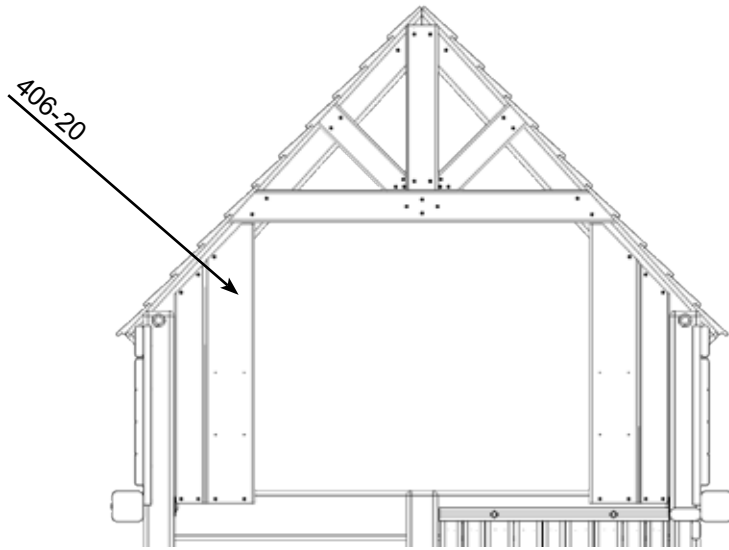

Treehouse Panel Install (Repeat for Both Sides)

PARTS NEEDED

- 406-3- 10 1/2" Treehouse Panel Board #1- (8)
- 406-12- 10 1/2" Center Panel Board- (4)
- 406-19- 30 1/2" Large Panel Board- (4)

HARDWARE NEEDED

- TP-1- 1 1/2" Coated Deck Screw- (40)

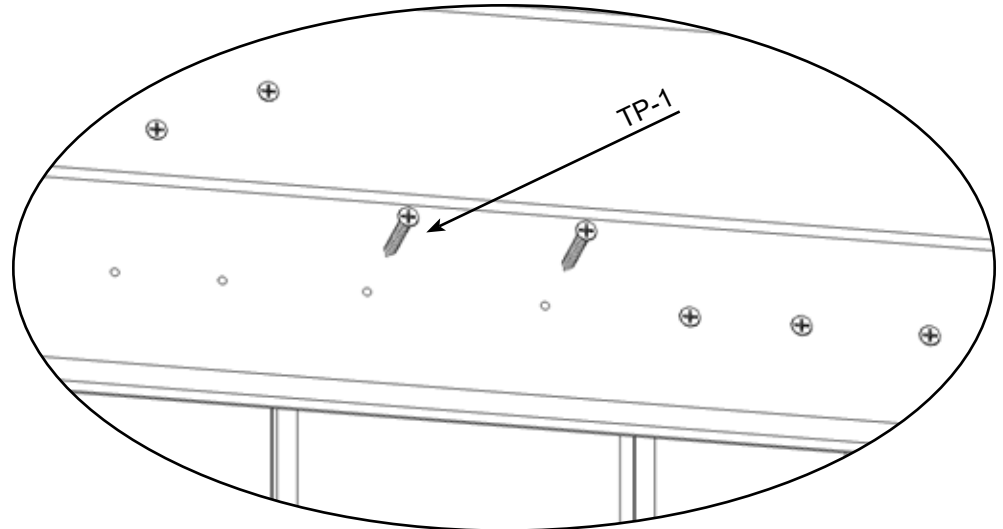
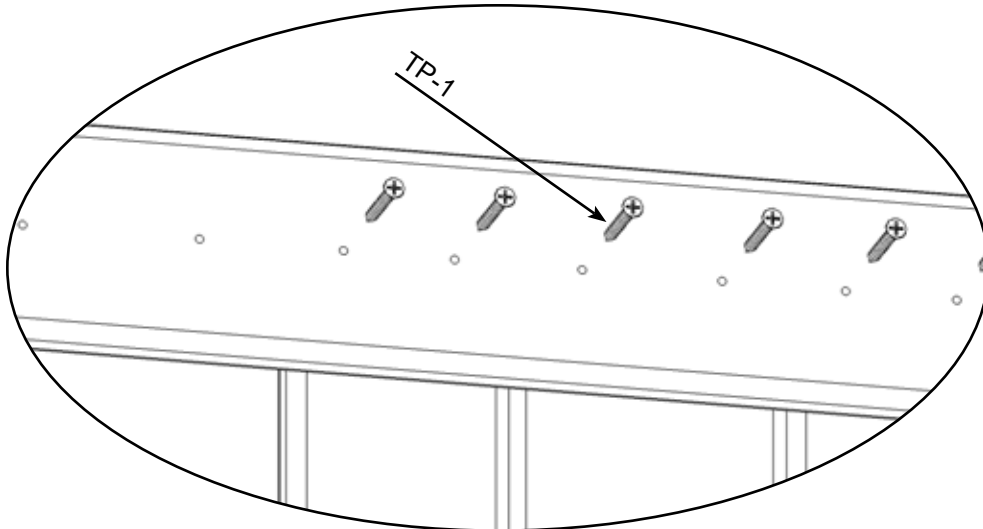
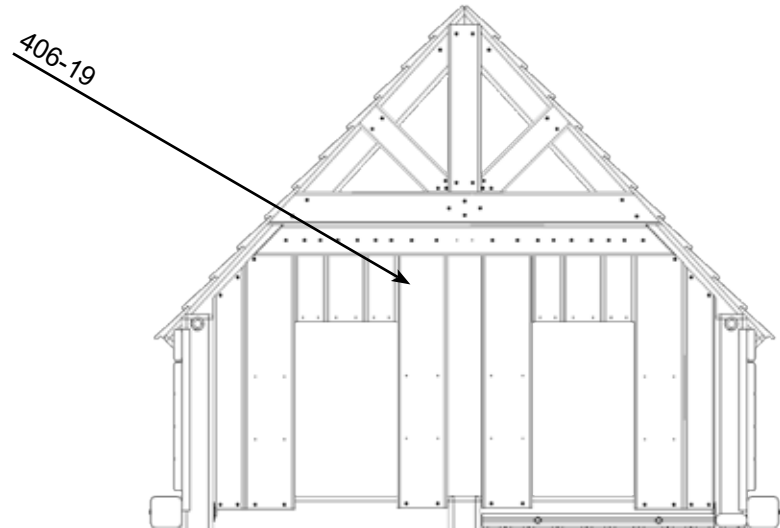
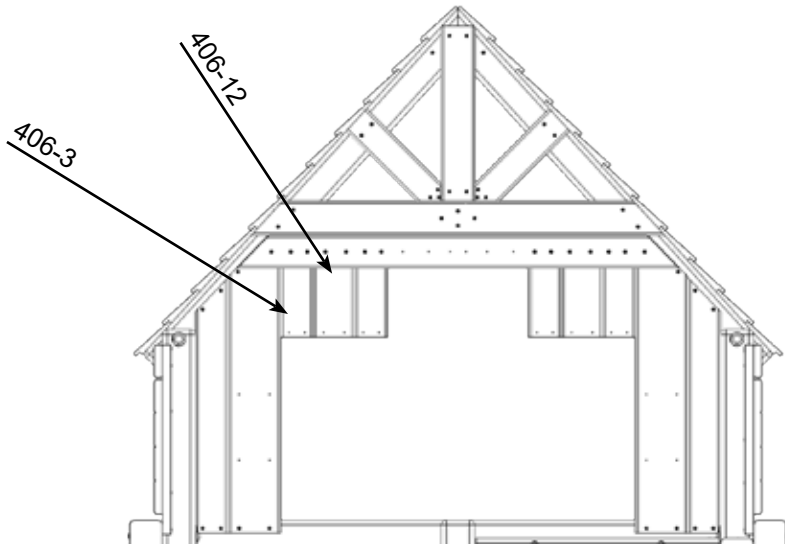

Treehouse Panel Install (Repeat for Both Sides)

PARTS NEEDED

406-9- 29" Center Panel Board- (2)
CC-016- 20" Window Arch- (4)

HARDWARE NEEDED

TP-1- 1 1/2" Coated Deck Screw- (44)

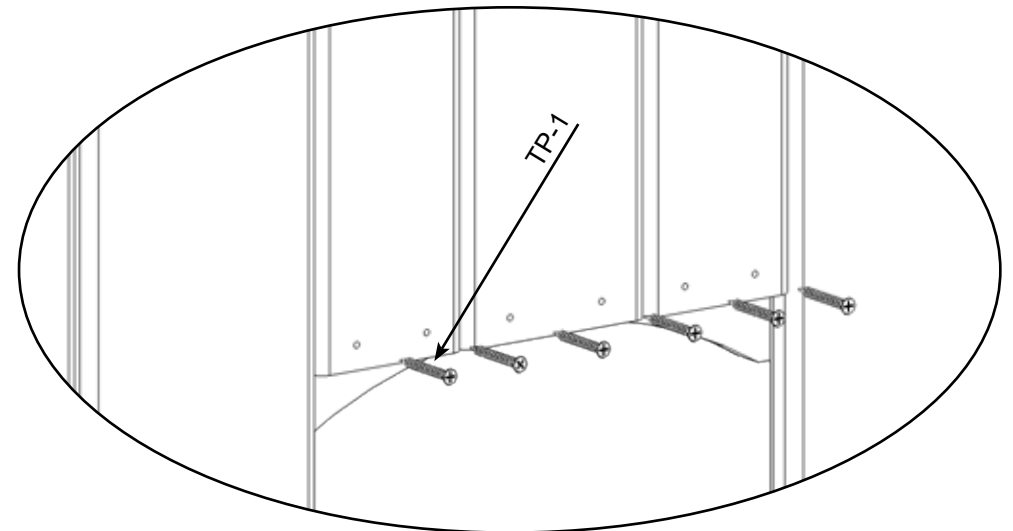
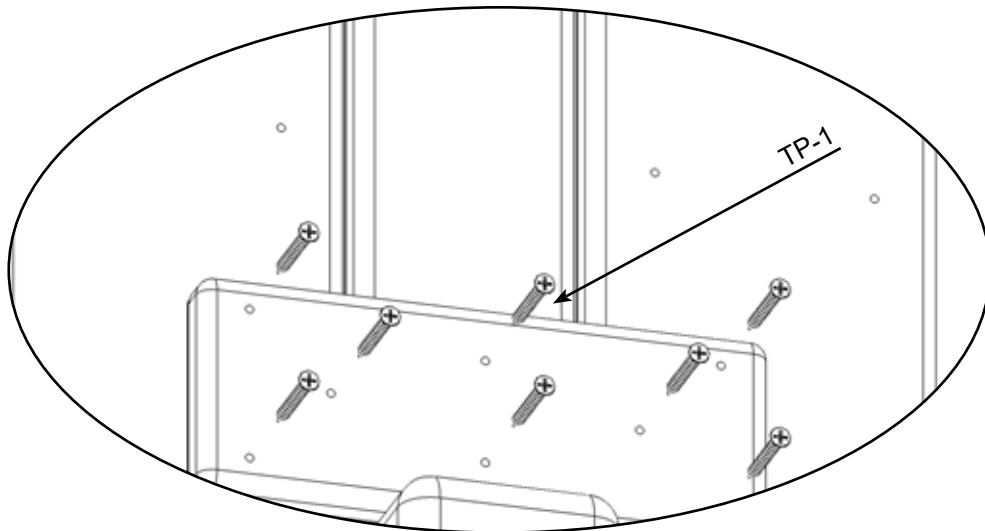
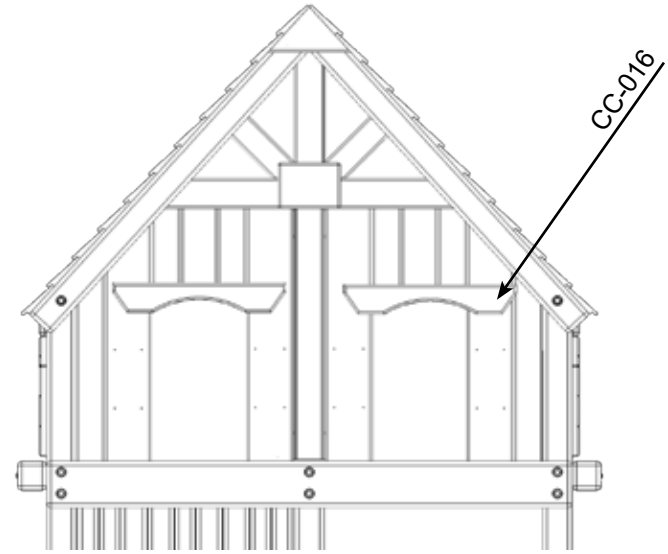
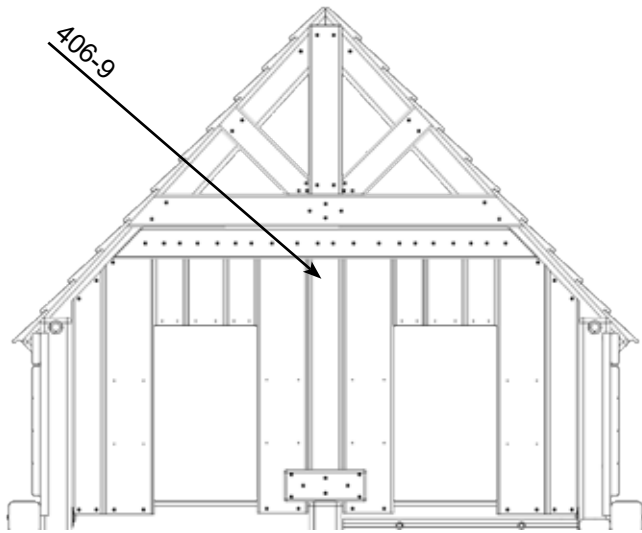

Treehouse Panel Install (Repeat for Both Sides)

PARTS NEEDED

- 406-17- 15" Left Shutter- (4)
- 406-16- 15" Right Shutter- (4)

Treehouse Finished Looks

HARDWARE NEEDED

- TP-1- 1 1/2" Coated Deck Screw- (32)

FINISHED TREEHOUSE ASSEMBLY WITH PICNIC TABLE



FINISHED TREEHOUSE ASSEMBLY WITH PLAYHOUSE PANELS

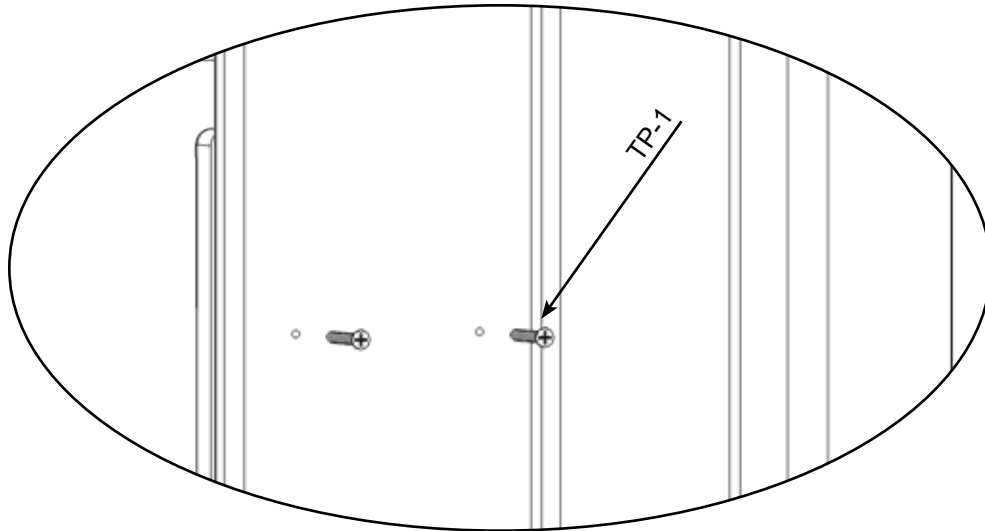
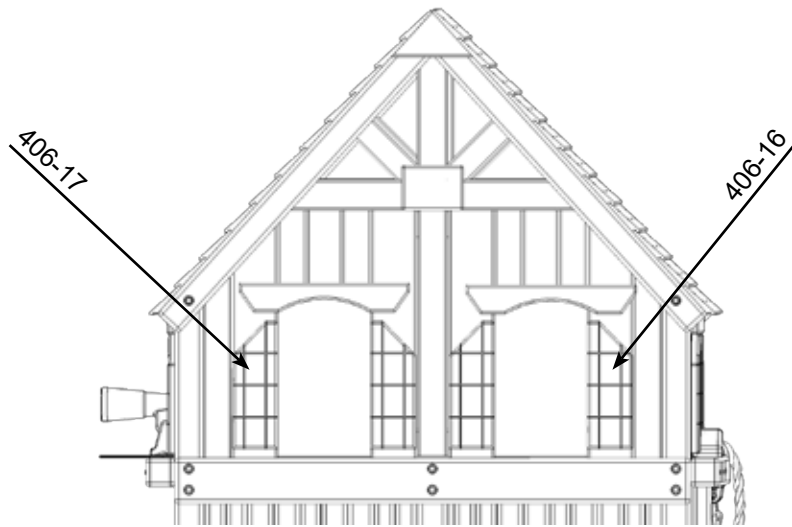

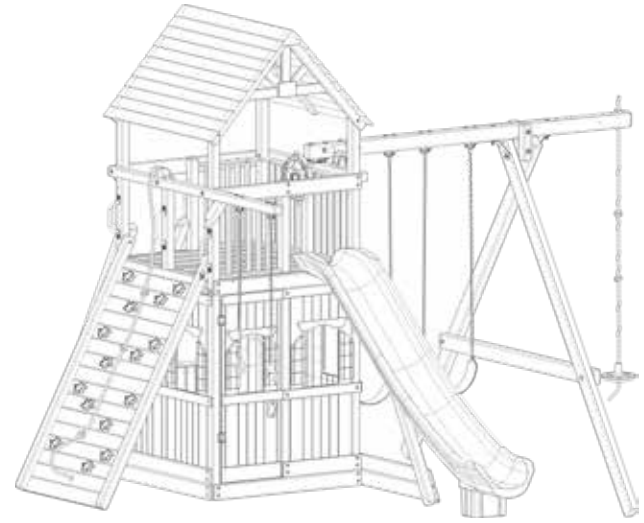
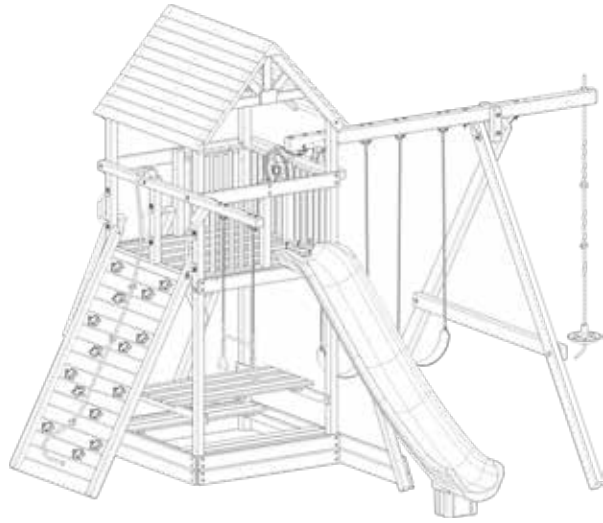

6.5 BENGAL FORT

